

acūrus

A2000-Series Amplifier User Guide 2, 5 and 7-channel models



INDY
AUDIO))) LABS

IMPORTANT SAFETY INSTRUCTIONS



CAUTION:
RISK OF ELECTRIC SHOCK!
DO NOT OPEN!



CAUTION! To reduce the risk of electric shock and fire, do not remove the cover or back plate of the device enclosure. There are no user serviceable parts inside. Refer servicing to an Acurus authorized service center.



CAUTION! The international symbol of a lightning bolt inside a triangle is intended to alert the user to uninsulated "dangerous voltage" within the device enclosure. The international symbol of an exclamation point inside a triangle is intended to alert the user to the presence of important operating, maintenance and servicing information in the manual accompanying the device.



WARNING! To reduce the risk of fire or electrical shock, do not expose this equipment to rain or moisture.

1. Read Instructions – All safety and operating instructions should be read before operating the device.
2. Retain Instructions – The safety and operating instructions should be retained for future reference.
3. Heed Warnings – All warnings on the device and in the operating instructions should be adhered to.
4. Follow instructions – All operating and safety instructions should be followed.
5. Attachments – Do not use attachments not recommended by the product manufacturer as they may cause hazards.
6. Water and Moisture – Do not use this product near water (for example, near a bath tub, wash bowl, kitchen sink, or laundry tub; in a wet basement; or near a swimming pool; and the like).
7. Ventilation – Slots and openings in the cabinet are provided for ventilation and to ensure reliable operation of the product and to protect it from overheating, and these openings must not be blocked or covered. The openings should never be blocked by placing the product on a bed, sofa, rug, or other similar surface. This product should not be placed in a built-in installation such as a bookcase or rack unless proper ventilation is provided or the manufacturer's instructions have been adhered to.
8. Heat – This product should be situated away from heat sources such as radiators, heat registers, stoves, or other products that produce heat.
9. Power Sources – This product should be operated only from the type of power source indicated on the marking label. If you are not sure of the type of power supply in your home, consult with your product dealer or the local power company. For products intended to operate from battery power, or other sources, refer to the operating instructions.
10. Grounding – This product is equipped with a three-wire grounding-type plug, a plug having a third (grounding) pin. This plug will only fit into a grounding-type power outlet. This is a safety feature. If you are unable to insert the plug into the outlet, contact your electrician to replace your obsolete outlet. Do not defeat the safety purpose of the grounding-type plug.
11. Power Cord Protection – Power supply cords should be routed so that they are not likely to be walked on or pinched by items placed upon or against them, paying particular attention to cords at plugs, convenience receptacles, and the point where they exit from the product.
12. Overloading – Do not overload wall outlets, extension cords, or integral convenience receptacles as this can result in a risk of fire or electrical shock.
13. Lightning and Periods of Non-Use – For added protection for this product during a lightning storm, or when it is left unattended and unused for long periods of time, unplug it from the wall outlet and disconnect the antenna or cable system. This will prevent damage to the product due to lightning and powerline surges.
14. Cleaning – Unplug this product from the wall outlet before cleaning. Do not use liquid cleaners or aerosol cleaners. Use a damp cloth for cleaning.
15. Object and Liquid Entry – Never push objects of any kind into this product through openings as they may touch dangerous voltage points or short-out parts that could result in a fire or electric shock. Never spill liquid of any kind on the product.
16. Damage Requiring Service – Unplug this product from the wall outlet and refer servicing to qualified service personnel under the following conditions:
 - a) When the power supply cord or plug is damaged,
 - b) If liquid has been spilled, or objects have fallen into the product,
 - c) If the product has been exposed to rain or water,
 - d) If the product does not operate normally by following the operating instructions. Adjust only those controls that are covered by the operating instructions as an improper adjustment of other controls may result in damage and often will require extensive work by a qualified technician to restore the product to its normal operation,
 - e) If the product has been dropped or damaged in any way, or
 - f) When the product exhibits a distinct change in performance – this indicates a need for service.
17. Replacement Parts – When replacement parts are required, be sure the service technician has used replacement parts specified by the manufacturer or that have the same characteristics as the original parts. Unauthorized substitutions may result in fire, electric shock, or other hazards.
18. Safety Check – Upon completion of any service or repairs to this product, ask the service technician to perform safety checks to determine that the product is in proper operating condition.
19. Servicing – Do not attempt to service this product yourself as opening or removing covers may expose you to dangerous voltage or other hazards. Refer all servicing to qualified service personnel. If this unit is purchased outside of the U.S., please contact your local dealer or distributor for service center information. If purchased inside the U.S. and dealer service is not available, contact Acurus Customer Service for a return authorization (RA) number before shipping. For further service information, contact:

ACURUS CUSTOMER SERVICE

phone: 1-866-781-7284

email: support@acurusav.com

5225 EXPLORATION DRIVE

INDIANAPOLIS, IN 46241

contents

2

Important Safety Instructions

3

Contents

4

Congratulations

Unpacking

- Outer and Inner Carton
- Package Contents
- Retain your Packaging
- Register your Product
- Record your Unit Information

5

Becoming Familiar with Your New Acurus Amplifier

- Front Panel
- Exterior Surfaces
- Rear and Bottom Panel

7

Placement and Setup

- Shelf Mounting
- Rack Mounting

8

System Planning and Optimizing

Making System Connections

- Speaker Outputs
- Audio Inputs
- Pre-amp On/Off Control
- Mains (AC) Power
- Control Networks

9

Operation

- Standby Mode
- Normal Operation
- Acurus' Proprietary Enhanced Ethernet Control (E2C)
- Amplifier Control and Status using E2C

14

Problem Resolution

- Troubleshooting Table
- Obtaining Additional Help

16

Technical Specifications

- A2002 Architects and Engineering Specifications
- A2005 Architects and Engineering Specifications
- A2007 Architects and Engineering Specifications

18

Design Notes

19

Warranty

- U.S. and Canada
- Applicable Territories

20

About Acurus and Indy Audio Labs

congratulations

Congratulations on your purchase of an Acurus A2000-series 2, 5 or 7-channel amplifier. Each Acurus A2000 series amplifier is a state-of-the-art component featuring high-end audio performance combined with unprecedented control and connectivity. Years of dedicated research, extensive testing, and engineering refinement went into the creation of this product. Since 1993, Acurus has been delivering high-value, high-performance electronics. Just like the first Acurus amps to roll off the assembly line nearly 20 years ago, your Acurus was designed, hand-assembled and tested with pride by engineers, technicians and skilled assemblers in the United States of America. You should expect years of trouble-free operation from your product investment.

Acurus components offer unparalleled performance and control flexibility for the most discriminating listener. Your A2000-series amplifier incorporates many advanced design and construction features combined in a superbly crafted amplifier.

unpacking

Outer and Inner Carton

Using a sharp object such as a knife or scissors, carefully open the outer single-walled (brown) shipping carton and inner double-walled (white) packaging cartons along their top seams.

Your Acurus amplifier is wrapped in a protective poly bag and sandwiched between 100% recycled foam bumpers. Carefully lift the amplifier out of the package with the foam bumpers attached.

TEAM LIFT! - To Avoid injury, lift with someone else - your amplifier is very heavy!

Package Contents

Inside the box you should find the following:

- 1. Acurus amplifier
- 1. Foam Bumpers (2)
- 1. Power Cord
- 1. User Guide
- 1. Warranty Card

In the unlikely event of any of the above items missing, immediately contact your dealer or Acurus Customer Service:

ACURUS CUSTOMER SERVICE

phone: 1-866-781-7284

email: support@acurusav.com

5225 EXPLORATION DRIVE
INDIANAPOLIS, IN 46241

Retain your Packaging

We highly recommend retaining your box and packaging materials as these are the best way to protect your amplifier in transit. Should warranty service be required, you MUST either use your original packaging materials or request new packaging from Acurus Customer Service (for a nominal fee).

Register your Product

In order to validate your purchase and qualify for the full five (5) year parts and labor manufacturer's warranty on your new Acurus product, you must have purchased it from an authorized Acurus retailer AND you must return the included warranty card completely filled out within 30 days of purchase.

Record your Unit Information

For future reference, we recommend recording your product information here:

Model No. _____

Serial No. _____

Date of Purchase _____

Date Registration Sent _____

becoming familiar with your new acurus amplifier

Your Acurus amplifier has been engineered to provide years of trouble-free enjoyment when installed and used according to this guide. This section will help you get familiarized with all the physical features of this component.

Front Panel

The front-panel design of your new Acurus was executed with beauty, simplicity and control confidence as the primary goals.



Power Button: To turn on your amplifier, simply press the power button. This custom-designed solid aluminum push-button responds with positive feedback. For automatic turn-on via an external pre-amp or pre-amp/processor, see section entitled **Pre-amp On/Off Control, p9**.

Status Light: Our proprietary status light design consists of a light ring surrounding the power button. This status light is clearly visible at a wide range of angles and in varying lighting conditions. It indicates amplifier status as shown below:



indication	meaning
unlit	No power input
steady red	Low-power (idle) mode
flashing red	Amplifier circuits initializing
blue	Amplifier ON

After pushing the power button, the light ring remains red briefly as the amplifier circuits are initialized. Once ready for audio, the light ring illuminates blue. To adjust the brightness of the light ring indicator for your particular environment via Acurus Enhanced Ethernet Control (E2C), see section entitled **Acurus' Proprietary Enhanced Ethernet Control (E2C), p10**.

Exterior Surfaces

The top and sides of your Acurus amplifier are designed for both style and function.

Top Cover: The brushed aluminum top cover contains ventilation slots to allow convective air flow through the internal chassis, drawing air from underneath to keep the internal circuit cards and transformer running cooler.



Sides: The extruded aluminum sides include heat transfer fins to direct heat away from the internal amplifier circuits to the ambient air. Unlike many other amplifier designs, Acurus A2000-series amplifier fins are mounted externally to achieve the most effective convective cooling action for all channels in both cabinet-mount and rack-mount installations.



Rear and Bottom Panel

The rear panel of your Acurus amplifier has been painstakingly designed for ease of installation.

Rear panel finish: The rear chassis features a durable powdercoat finish to provide both scratch resistance and high-contrast colors for installation in dimly-lit environments. All labels are clear and concise utilizing easy-to-read fonts.



Speaker Outputs: Speaker outputs are discrete, rugged, 60-amp gold-plated binding posts with anti-touch protective clear housings.

All posts are color-coded with red and black rings for + and - speaker polarity and are spaced in pairs to accommodate dual banana jacks. All pairs are angled to minimize tangling and strain on heavy gauge speaker wire exits, particularly in rack installations.



Audio Inputs: Each audio input consists of a high-conductivity, gold-plated, isolated RCA jack logically arranged near its corresponding output connection. Rear panel graphics clearly indicate which inputs correspond to which outputs.

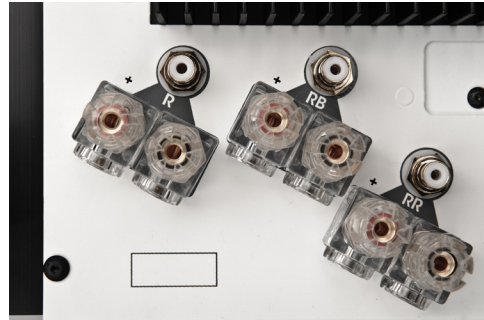

AC Mains Inlet: The AC mains inlet is a removeable IEC-320-style high-current appliance inlet with integral mains fuse holder. This inlet is approved for international use.

Network Module: Your new Acurus amplifier includes built-in remote control and networking capabilities that provide a wide array of options and ultimate installation flexibility. All these functions are provided in an upgrade-able hardware card.



1 - External 12V Trigger Input Within the network module section, a 3.5mm jack allows for connection to a typical 5-24V trigger output from an external pre-amp or pre-amp/processor via a stereo 3.5mm cable.

2 - System Controller (RS-232) Input The network module section contains an RS-232 DB-9 connector for interface to an external system controller. Contact Indy Audio Labs for a list of verified control system manufacturers.

3 - Ethernet Network Active LED The Ethernet Network Active LED illuminates green with an active network connection between the Acurus amplifier and a network switch or router.

4 - Ethernet Jack The Ethernet jack enables connection to either an external system controller or to a standard home Ethernet 10/100 network switch or router port. Control and status monitoring of the amplifier using any device with a web browser is supported via the web server embedded in the Acurus amplifier.

Feet: Heavy-duty thermoplastic rubber feet ensure good underside airflow, isolate your amplifier from external vibration and protect the surface finish of AV furniture underneath.

For rack-mount installations where other equipment is installed directly adjacent, these feet are easily removed.

placement and setup

An enjoyable home entertainment experience always begins with carefully planned placement and setup of system components. This section will provide guidance on how to best install your new Acurus amplifier.

Shelf Mounting

When planning to mount on a shelf, be aware of the physical dimensions of your Acurus amplifier as outlined in the section entitled **Technical Specifications, p16**.

It is ALWAYS advisable to:

1. Provide ample space above the unit (1-2 inches is the minimum preferred)
2. Provide plenty of room (at least 1-2 inches) between the sides of the unit at nearby surfaces or other components
3. Locate the unit near an AC outlet or power conditioner and avoid using extension cords or power strips
4. Locate the amplifier as close as possible to the pre-amp or pre-processor
5. Use as short length wire leads as practical, especially on the amplifier inputs
6. Connect the amplifier to the same mains circuit as the pre-amplifier

It is NEVER advisable to:

1. Enclose the unit in a cabinet without air flow or adequate ventilation, particularly across the heat fins along the side and back of the unit.
2. Place the unit near a source of moisture such as a window or a live plant
3. Place other components in a stack on top of the amplifier
4. Place the amplifier on a carpeted surface
5. Remove the safety ground connector from the AC mains cord

Rack Mounting

Your Acurus amplifier can easily be configured to mount in a standard 19-inch rack cabinet with an optional Acurus rack mount accessory kit. Hardware and detailed installation instructions are included.

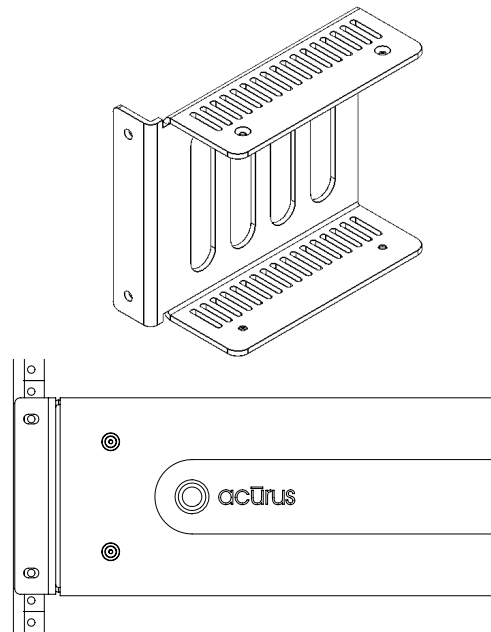

model	acurus rack-mount kit part number
A2002	1000548
A2005	1000549
A2007	1000549

Contact your dealer or Acurus Customer Service with questions or to request the rack mount kit designed specifically for your amplifier model.

system planning and optimizing

In order to experience the best performance from your amplifier, the entire system needs to be planned and components carefully selected to work together. Your authorized Acurus dealer is trained to be able to help you ensure your components work well together.

The following are some helpful guidelines to ensure your Acurus amplifier is well-matched to the other components in your system.

1. Quality loudspeakers can have a dramatic impact on overall sound quality in a system for a given room environment. When planning or upgrading a system, as a rule of thumb, we recommend budgeting for loudspeakers at or somewhat above the price range of your amplifier electronics. Your Acurus dealer will be able to advise you on best loudspeaker selection for your electronics, your environment, and, most importantly, your listening preferences.
2. Using higher-efficiency loudspeakers (87dB/W/m or greater) will reduce the average amount of amplifier power consumed to produce a target listening loudness. This effectively helps reserve greater peak amplifier power when loud transient passages are reproduced.
3. High-power amplifiers (over 100W continuous into 8 ohms) are generally OK to pair with speakers with slightly lower power ratings, particularly if subwoofers are involved. Higher-power amplifiers will tend not to go into clipping distortion as readily as lower-powered amplifiers or receivers. Clipping is a type of distortion that is prone to damage loudspeakers.
4. Preamps should be chosen with output voltage swing capability equal to or greater than the amplifier sensitivity spec for full rated power output (for example, 1.42V for full rated output). Similarly, an ideal preamp choice has a noise spec less than or equal to that of the power amplifier.

5. Well-designed computer-based audio sources should have isolated grounds in order to avoid hum and buzz associated with connecting audio systems with typical digital system power supplies. Your Acurus dealer can recommend good quality components that meet these criteria.
6. Systems with cable TV or satellite source components may need isolation transformers or other ground isolation devices (such as the Modial "MAGIC" box) in order to reduce or eliminate hum due to ground loops.

making system connections

Your Acurus amplifier is designed for simple, reliable connections in a variety of system configurations. Following the instructions below will ensure optimal performance from your amplifier.

Speaker Outputs

Use a high-quality speaker cable with sufficient gauge wire for the loudspeaker run lead length. Be sure to observe consistent speaker polarity connections (plus (+) and minus (-) speaker leads) from amplifier to loudspeaker. The Acurus A2000 series amplifiers are non-polarity inverting.

Physical connection options supported include bare wire, single banana post, dual banana post, spade connector and wire lead.

Connect loudspeakers to their corresponding speaker terminals as follows:

rear panel label	loudspeaker position
L	Front left
R	Front right
C	Center
LR	Rear surround left
RR	Rear surround right
LB	Back surround left
RB	Back surround right

Audio Inputs

We recommend using good quality RCA interconnects to connect the preamp output to the amplifier inputs. Use the same connection scheme as in the table above.

Pre-amp On/Off Control

To enable an external 2-channel or surround preamp to power on your Acurus amplifier, connect the trigger out from the preamp to the the 3.5mm jack labelled 12V trigger on the Acurus. The jack is wired with its tip active and will accept a stereo or mono plug.

3.5mm stereo plug

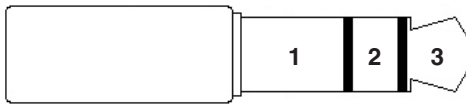

- 1 – Ground
- 2 – Ground
- 3 – Trigger Voltage

NOTE: the front panel power button functions normally even if the trigger input is used. The Acurus amplifier will automatically resume control sync with the external preamp after the next time system power is cycled.

Mains (AC) Power

Your Acurus A2000 series amplifier is equipped with a high-quality 16 gauge, 3-conductor power cord. Plug this cord into the back of the amplifier and then into a nearby AC outlet. Avoid using any extension cords or plugging into other components with rear-panel switched outlets. If using the amplifier with a power conditioner, ensure that the receptacle your amplifier plugs into is capable of providing the full current required by the amplifier. See section entitled **Technical Specifications, p16** for a list of current requirements for each model amplifier in the A2000 series.

It is recommended practice to connect AC power only after all other connections have been made.

Control Networks

Ethernet: In order to take advantage of Acurus Enhanced Ethernet Control (E2C), connect the Ethernet port to a 10/100 or faster home network router or switch port via a standard CAT 5e or newer Ethernet cable. The network activity indicator near the Ethernet jack illuminates green when network activity is detected.

This port may also be directly connected to a system controller utilizing Ethernet command protocols. Contact your dealer or Acurus Customer Service in order to verify compatibility with certain control systems.

RS-232: Connect this port to a system controller using a 9-pin RS-232 serial cable in order to control and monitor the amplifier remotely. Contact your dealer or Acurus Customer Service in order to verify compatibility with certain control systems.

operation

This section discusses the normal operation of your Acurus amplifier and highlights the control flexibility engineered into this component.

Standby Mode

When first connected to AC power, your Acurus amplifier initializes in standby mode. This is indicated by a red illuminated Status Light. Normally, the initialization process takes a few seconds. Once the amplifier is initialized, it is ready to be powered on.

Before powering on, ensure that your preamp volume level is not too high or else speaker damage may occur.

Turn on the amplifier by pressing the front panel power button. If an external trigger input from a preamp is used, turning on the preamp should automatically turn on the amplifier. The Status Light turns blue indicating the amplifier is active. Toggling the power button again puts the amplifier back into standby mode.

LAST ON, FIRST OFF! – To avoid potential loud pops and/or hum, always turn on the amplifier last after other components such as pre-amps and sources and turn off the amplifier first when powering down.

Normal Operation

Observe these simple guidelines during normal operation:

Source Material: Your Acurus amplifier will sound only as good as the source material it is amplifying. We recommend CD-quality or higher bitrate sources in order to experience the full capabilities of your new amplifier. You'll probably find that MP3 or other lossy, compressed (less than 256Kbps bitrate) source audio lack the detail and definition that your Acurus components are capable of delivering.

Break In Period: While we burn-in each unit at the factory before it is shipped, we recommend playing your amplifier a minimum of 24 hours before performing any critical listening.

When not in Use: We do not recommend leaving the amplifier on continuously as a means of somehow improving its long-term reliability or sonics. As with prior Acurus designs, we've designed the A2000 series amplifiers to come up to operating temperature in a few short minutes and have chosen components that can handle temperature cycles well beyond the intended life of the product.

We can minimize electric utilization and preserve our global environment by taking advantage of the low-power standby mode these amplifiers offer.

Acurus' Proprietary Enhanced Ethernet Control (E2C)

Enhanced Ethernet Control allows the user or installer to quickly and easily control and monitor the status of Acurus components over a home network. For the A2000 series amplifiers, this capability provides a useful setup and diagnostic tool.

Setting up Enhanced Ethernet Control (E2C): To enable E2C, the amplifier must be connected directly to a network router or switch as indicated by the green network activity LED on the rear panel of the amplifier. After a couple minutes connected to the network, the amplifier network module will be initialized and the amplifier will be controllable as a network device.

Any networked computer, smartphone or tablet connected to the local network and running up-to-date web browser software may be used to control and monitor the amplifier. To access the control page of the amplifier, the amplifier's IP address must be typed in the browser URL line of the controlling device.:

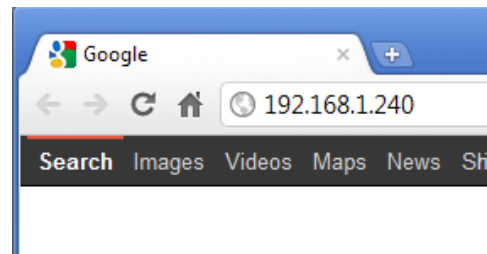

Because most network routers default to allow DHCP (service running on the router) to automatically assign IP addresses to network devices, it is necessary first to discover the specific IP address assigned to the amplifier by the network router. There are a few common methods to accomplish this.

Manual Network Discovery: Below are several methods that can be used to discover an Acurus A2000 series amplifier on a local network. The critical information for identifying the Acurus component is that the A2000 series mac address always is formatted with the first 3 pairs of numbers constant as:

MAC Address 00:03:75:XX:YY:ZZ

Discovering the IP address with a Mobile Device:

On a mobile device such as an iPad or iPhone, download one of several available IP address scanner programs such as iNet or IP Scanner. Programs such as these are typically free or available for sale for a nominal fee. Similar Android and other mobile OS apps are available with this capability. These programs scan the entire network and list the connected devices, their IP addresses and their MAC addresses.

IP Discovery via Traditional Computer: On a laptop or desktop computer, login to the local router administration software, open the list of attached devices and note the assigned IP address of the amplifier from the list of connected devices on the local network.

Amplifier Control and Status using E2C

To illustrate how to control and monitor status of an Acurus amplifier using E2C, let's assume you are operating on a DHCP-enabled network and have discovered the amplifier at IP address 192.168.1.125. You can now connect to the amplifier using your control computer or mobile device by typing the above IP address in the browser window.

A view of the main control page similar to the one below should appear (A2007 shown):

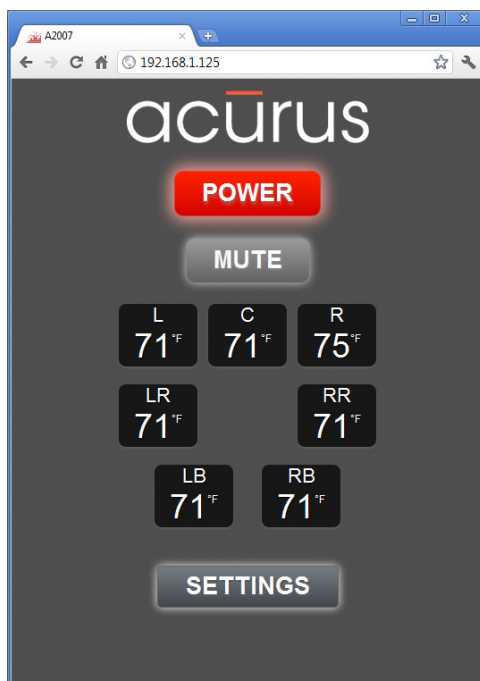

Power: This button performs the same function as the front panel button on the amplifier. The color of the button matches the light ring on the physical unit. It toggles the unit between “on” and “standby” operation.

Mute: The mute button removes the audio output from all channels of the amplifier to the loudspeakers while keeping the amplifier channels powered on. In addition to providing a quick way to cut out audio in a room, this feature is useful for breaking the signal path to help diagnose possible sources of noise or other issues.

Channel Temperature Indicators: These indicators provide real-time temperature information from each of the channels. When in standby, or after initial power up, these indicators will typically match room temperature (within a few degrees). After several minutes of warm up, when the channels have reached normal operating temperature, these meters normally indicate channel temperatures in the 95-110 degree F range. It is not unusual to have up to 9 degrees of variation from channel-to-channel. However, if one particular channel is running outside this range, there may be an abnormal condition such as a mismatch with a speaker load or service adjustments that need to be made on the amplifier by a service technician. The number of Channel Temperature Indicators in this view varies according to the number of channels (2, 5 or 7) the amplifier model provides.

Settings Button: The settings button opens the settings page of the interface.

Settings Page: The top section of the settings page shows each channel's functional status (either "ACTIVE" or "PROTECT") along with an individual channel mute button. A channel reports PROTECT status if an overtemp condition is encountered. The channel input is automatically disconnected until the temperature sensed is back within operating range.

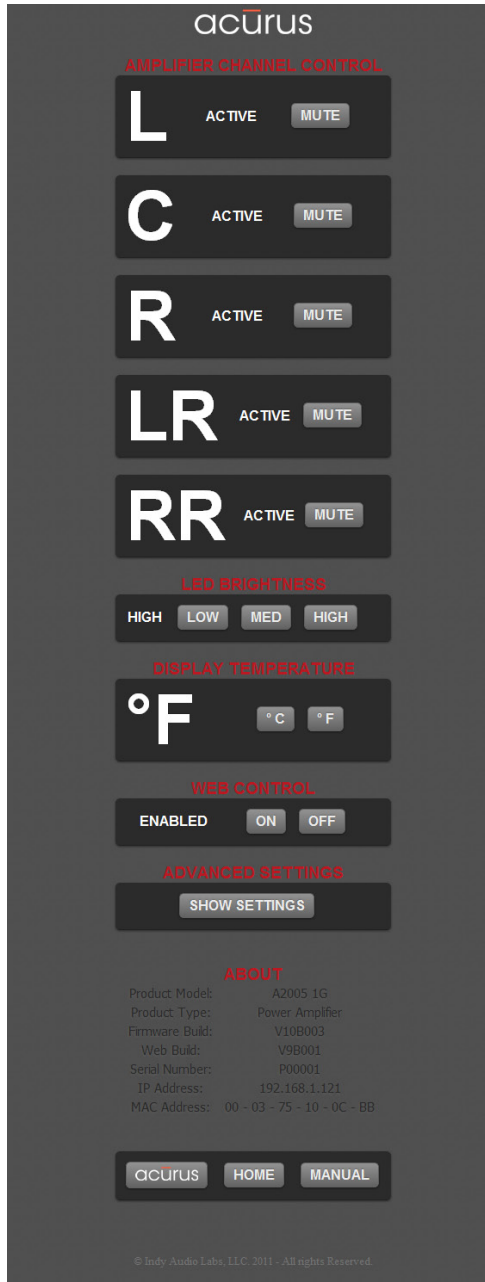

Individual Channel Mute: The individual channel mutes allow for simple troubleshooting and setup of individual channels, particularly in a multi-channel surround setup. When muted, the mute button illuminates red as below:

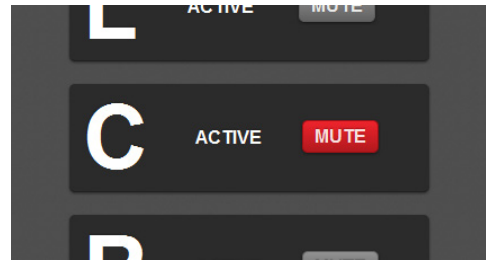

Front Panel Illumination Brightness Control: The front panel status ring may be too bright for installations with low lighting levels or more dimly illuminated companion equipment. This section of the control interface allows the default brightness level to be customized from high to medium or low.

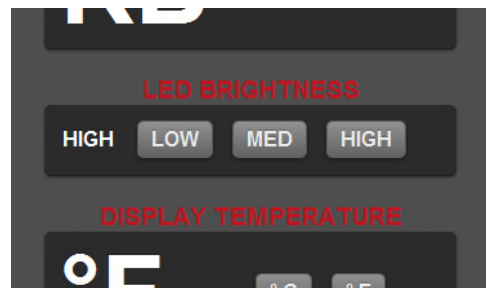

Temperature Display Units: This section toggles the displayed temperature units from degrees F to degrees C and vice versa.

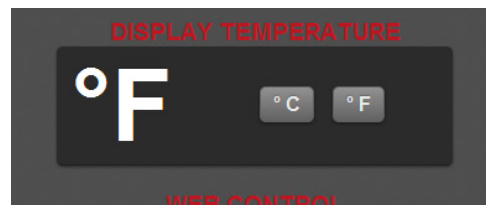

Web Control Enable: This on/off toggle is used for installations in which RS-232 or Ethernet commands are sent from an external control system rather than via web browser control.

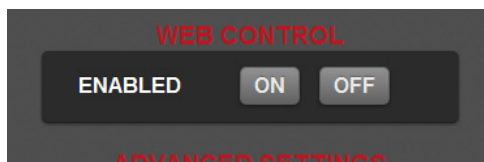

About Information Section: This section contains useful information such as product model, software version, IP address, MAC address as well as buttons to view the Acurus web page <http://www.acurusav.com>, and a button to view the latest version of the online user guide.



Advanced Settings: By selecting the “Show Settings” button in the Advanced Settings section, advanced information boxes appear that allow advanced control functions and monitoring including:

1. Forcing a static IP address – used for creating persistent links to the control page on a computer or mobile device. (Note that an alternate method to accomplish this is to force a static IP for this MAC Address in the local router.) The initial IP address of the amplifier is set to a default value per the table below:

model	default ip address
A2002	192.168.1.250
A2005	192.168.1.241
A2007	192.168.1.240

Press the “Static” button and enter a new static IP address or simply hit “Enter” to accept the default ip address. Then press the “Upload New IP” button to change the current IP address to the new Static IP address. The new Static IP address will be set and the next time a browser is pointed to this IP address, a permanent control link can be easily created on the control device’s desktop.

2. Restoring automatic DHCP address assignment - press the DHCP button to force the internal web server to request a new address from the network DHCP server.
3. Enabling/disabling UDP commands – prevents the amplifier from responding to Ethernet network commands. In most cases, when no external Ethernet controller is present, this can be turned off to add an additional level of network security.
4. Changing external controller type - in cases where an external Ethernet or Serial Control System is present, either Ethernet or Serial control can be selected.
5. Showing status on whether an internet connection is present.

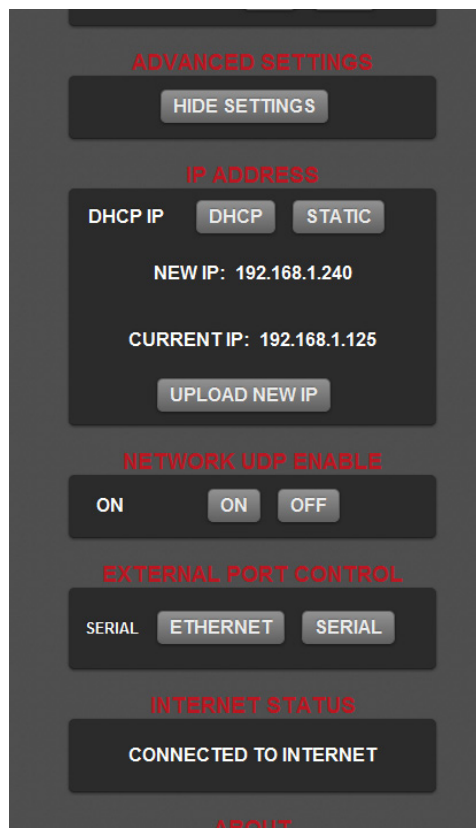

problem resolution

From time to time, problems may occur. The following table is intended to help categorize and solve issues that may arise. Of course, if problems persist, do not hesitate to call your local dealer or Acurus Customer Service.

Troubleshooting Table

problem or symptom	possible causes	recommendations
Amplifier does not power on – no front panel lights	AC not connected	<ul style="list-style-type: none"> • Check that power cord is connected at the wall and at the back of the unit. • Check that switched AC outlets are on. • Check that power conditioner is on (if applicable).
	Blown or missing mains fuse	Check fuse compartment in back of unit near AC inlet. Replace fuse and retest. If problem persists, refer unit to service personnel.
Amplifier powers on with red standby light but does not switch on with blue light indicator via web control	Control device not connected to local network	<ul style="list-style-type: none"> • Check to ensure control device is connected to the local network and not another neighboring network. • Check to ensure that all network routers and switches are powered up and active.
	Amplifier disconnected from local network	Check network activity light – if not illuminated green, check opposite end of cable. If cable is plugged in and switch or router shows activity indication, replace network cable.
Amplifier switches on (blue indicator) but does not produce audio	Loudspeakers disconnected	Check loudspeaker connections at the amplifier and at the speaker terminals. Look for frayed or disconnected leads.
	Pre-amp not powered on	Check preamp power status.
	Pre-amp not connected properly	Check to ensure amplifier inputs are connected directly from corresponding pre-amp outputs via good RCA cables.
	Source device disconnected	<ul style="list-style-type: none"> • Check connections between source device and pre-amp. • Try using an alternate source device to eliminate the possibility of a pre-amp problem.
	Web control global or channel mutes active	Using web control, check mute button states on main view and advanced views. Alternately, reset AC power to the unit to reset the mute states. Note that with DHCP control, this may reset the unit IP address.
Not all amplifier channels appear to be working	Shorted or open speaker leads	Check loudspeaker connections at the amplifier and at the speaker terminals. Look for frayed or disconnected leads.
	Pre-amp not connected properly	Check to ensure amplifier inputs are connected directly from corresponding pre-amp outputs via good RCA cables.
	Loudspeaker problem	Disconnect problem loudspeaker and reconnect it to a known good amplifier channel.
	Preamp or source device surround mode problem (applies primarily to A2005, A2007)	Check that speaker sound is supported in the processing mode that is active. For example, a center channel speaker will be silent in Dolby Digital 2.0 mode. Likewise, for speech playback, often the left and right front speakers will be silent in Dolby Pro Logic mode. Refer to the information that came with the preamp or source device.
	Web control global or channel mutes active	Using web control, check mute button states on main view and advanced views. Alternately, reset AC power to the unit to reset the mute states. Note that with DHCP control, this may reset the unit IP address.
	Blown channel protection fuse(s)	Can sometimes occur after faulty connection to good loudspeaker OR good connection to faulty loudspeaker.

problem or symptom	possible causes	recommendations
Amplifier sound is garbled or distorted	Shorted or open speaker leads	Check loudspeaker connections at the amplifier and at the speaker terminals. Look for frayed or disconnected leads.
	Pre-amp not connected properly	Check to ensure amplifier inputs are connected directly from corresponding pre-amp outputs via good RCA cables.
	Loudspeaker problem	Disconnect problem loudspeaker and reconnect it to a known good amplifier channel.
Hum persists only when amplifier is on – goes away in standby	Partially connected or faulty RCA input cable	<ul style="list-style-type: none"> • Check for RCA plugs not seated completely in jacks • Isolate and replace faulty cable.
	Bad AC ground connection	<ul style="list-style-type: none"> • Check to ensure the original 3-conductor heavy-gauge power cord that shipped with your Acurus is used for the amplifier. • Try a different power outlet in case the wall outlet ground is defective. • Attempt to power the system from a single AC outlet to minimize ground loops.
	Cable or Satellite TV connection causing hum	Verify source by disconnecting incoming cable line or satellite dish cable to see if hum disappears. If this is the source, then hum will disappear when the cable is disconnected from the system. If so, use an isolation transformer (or Mondial Magic Box) at each of the cable and/or satellite inputs.
Cannot control amplifier from mobile device or computer	Control device not connected to local network	<ul style="list-style-type: none"> • Check to ensure control device is connected to the local network and not another neighboring network. • Check to ensure that all network routers and switches are powered up and active.
	Amplifier disconnected from local network	Check network activity light – if not illuminated green, check opposite end of cable. If cable is plugged in and switch or router shows activity indication, replace network cable.
	Incorrect IP address input to controlling computer or mobile device browser	Check IP address on host router or using an IP scan tool. If IP address is correct, perform full power reset of amplifier (remove and reinsert AC inlet cord).
Turning on pre-amp does not automatically turn on amplifier	Trigger cable missing or plug not seated fully in trigger in jack	Check trigger cable connections and re-test.
	Trigger voltage outside acceptable range	Refer to pre-amp information to ensure the trigger output falls into the range 5-24Vdc.
Amplifier runs for a while then one or more channels cut out	Faulty (shorted) loudspeaker connection	Check loudspeaker connections at the amplifier and at the speaker terminals. Look for frayed leads touching each other or touching chassis metal.
	Faulty loudspeaker	Remove loudspeaker and re-check channel with a known-good loudspeaker.
Amplifier runs hot even at low audio levels	Ventilation inadequate	Check to ensure that sides, rear and top of unit have at least 2 inches of air space and that air can flow in and out of space around amplifier installation.
	Low impedance loudspeaker load	Check to ensure that the loudspeakers are greater than or equal to 4 ohms nominal impedance.
	Faulty (shorted) loudspeaker connection	Check loudspeaker connections at the amplifier and at the speaker terminals. Look for frayed leads touching each other or touching chassis metal.
	Faulty loudspeaker	Remove loudspeaker and re-check channel with a known-good loudspeaker.

Obtaining Additional Help

For problems not addressed here, have the model, serial number and date of purchase of your Acurus compo-

nent handy and contact your local dealer or contact Acurus Customer Service at 1-866-781-7284 M-F, 9AM to 5PM E.S.T. or email support@acurusav.com.

technical specifications

All Models	Power output	200W into 8Ω, multiple channels driven 300W into 4Ω, multiple channels driven
	THD	< 0.03%, multiple channels driven, full power, 8 ohms < 0.05%, multiple channels driven, full power, 4 ohms
	Frequency response	20Hz to 20kHz ± 0.1 dB 10Hz to 70kHz +0, -3dB
	Tim/dim distortion	< 0.003%
	S/N	>106 dB, A-weighted
	Damping factor	500, 8Ω @50Hz
	Input sensitivity	1W: 100mV 200W: 1.42V
	Input impedance	20kΩ
	Recommended loudspeaker impedance range	4-8 ohms nominal
	DC offset (output)	<3mV
	Rail voltage	+/-80Vdc
	THX Ultra2	Certified
	A2002 only	Number of channels driven for continuous power spec
Power consumption		Standby: 1W Idle: 23W Max: 1200W
Unit dimensions (LxWxH)		13.5 x 17 x 5 (inches), 34 x 43 x 13 (cm)
Rack height		3 RU
Unit weight		29lbs (13kg)
Finish		Black anodized aluminum with laser-etched markings
Shipping carton (LxWxH)		22 x 18 x 10 (inches), 56 x 46 x 25 (cm)
A2005 only	Carton weight	35lbs (16kg)
	Number of channels driven for continuous power spec	5 channels, music at 50% duty cycle 4 channels, sine wave, 8 ohms
	Power consumption	Standby: 1W Idle: 75W Max: 1440W
	Unit dimensions (LxWxH)	15 x 17 x 9 (inches), 38 x 43 x 23 (cm)
	Rack height	5 RU
	Unit weight	47lbs (21kg)
	Finish	Black anodized aluminum with laser-etched markings
A2007 only	Shipping carton (LxWxH)	22 x 20 x 16 (inches), 56 x 51 x 41 (cm)
	Carton weight	55lbs (25kg)
	Number of channels driven for continuous power spec	7 Channels, music at 50% duty cycle 4 Channels, sine wave, 8 ohms
	Power consumption	Standby: 1W Idle: 85W Max: 1440W
	Unit dimensions (LxWxH)	15 X 17 x 9 (inches), 38 x 43 x 23 (cm)
	Rack height	5 RU
	Unit weight	52Lbs (24kg)
A2007 only	Finish	Black anodized aluminum with laser-etched markings
	Shipping carton (LxWxH)	22 X 20 x 16 (inches), 56 x 51 x 41 (cm)
	Carton weight	60Lbs (27kg)

A2002 Architects and Engineering Specifications

The audio amplifier shall provide 2 output channels and produce 200W continuous power into 8 ohms, each channel driven.

The unit shall include a 10/100 Ethernet port and an RS-232 port for remote control and status monitoring. A 12V Trigger port shall be included to allow remote on/off triggering by an external preamp or power control center. The amplifier shall have an internal web server which delivers a browser-compatible GUI. This GUI shall allow for remote control and monitoring via computer or mobile device/An RS-232 port.

The unit shall have adjustable front panel lighting levels for dimly lit environments or bright rooms. The rear panel shall have gold-plated input RCA connectors and gold-plated 60A-rated loudspeaker binding posts.

The unit shall contain a worldwide configurable power supply, and be compliant with FCC Part 15 and CE requirements.

The unit shall be the Acurus A2002.

A2005 Architects and Engineering Specifications

The audio amplifier shall provide 5 output channels and produce 200W continuous power into 8 ohms, each channel driven.

The unit shall include a 10/100 Ethernet port and an RS-232 port for remote control and status monitoring. A 12V Trigger port shall be included to allow remote on/off triggering by an external preamp or power control center. The amplifier shall have an internal web server which delivers a browser-compatible GUI. This GUI shall allow for remote control and monitoring via computer or mobile device/An RS-232 port.

The unit shall have adjustable front panel lighting levels for dimly lit environments or bright rooms. The rear panel shall have gold-plated input RCA connectors and gold-plated 60A-rated loudspeaker binding posts.

The unit shall contain a worldwide configurable power supply, and be compliant with FCC Part 15 and CE requirements.

The unit shall be the Acurus A2005.

A2007 Architects and Engineering Specifications

The audio amplifier shall provide 7 output channels and produce 200W continuous power into 8 ohms, each channel driven.

The unit shall include a 10/100 Ethernet port and an RS-232 port for remote control and status monitoring. A 12V Trigger port shall be included to allow remote on/off triggering by an external preamp or power control center. The amplifier shall have an internal web server which delivers a browser-compatible GUI. This GUI shall allow for remote control and monitoring via computer or mobile device/An RS-232 port.

The unit shall have adjustable front panel lighting levels for dimly lit environments or bright rooms. The rear panel shall have gold-plated input RCA connectors and gold-plated 60A-rated loudspeaker binding posts.

The unit shall contain a worldwide configurable power supply, and be compliant with FCC Part 15 and CE requirements.

The unit shall be the Acurus A2007.

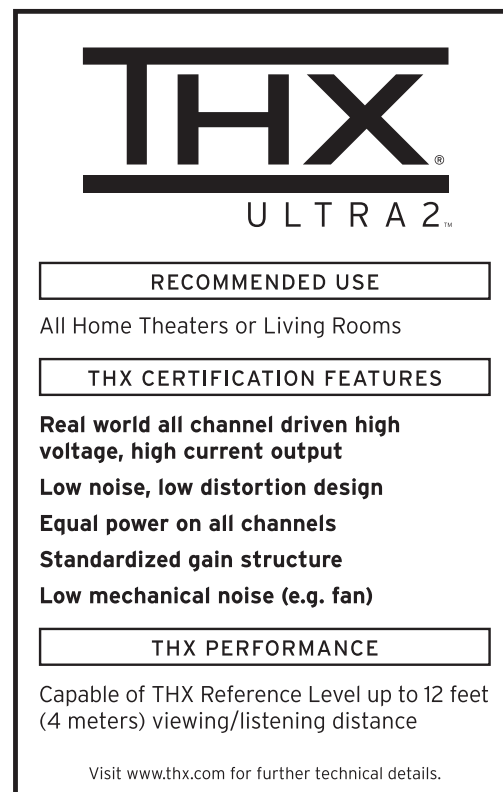

The image shows a THX ULTRA 2 certification box. At the top is the THX logo with 'ULTRA 2' underneath. Below the logo is a section titled 'RECOMMENDED USE' which lists 'All Home Theaters or Living Rooms'. The next section is 'THX CERTIFICATION FEATURES' and lists: 'Real world all channel driven high voltage, high current output', 'Low noise, low distortion design', 'Equal power on all channels', 'Standardized gain structure', and 'Low mechanical noise (e.g. fan)'. Below that is a section titled 'THX PERFORMANCE' which states 'Capable of THX Reference Level up to 12 feet (4 meters) viewing/listening distance'. At the bottom of the box, it says 'Visit www.thx.com for further technical details.'

THX and Ultra2 are trademarks of THX Ltd.
THX is registered in some jurisdictions. All rights reserved.

design notes

The Acurus A2000 series was designed by engineers at Indy Audio Labs to deliver audio experiences unmatched by any other products in their category. While not an easy task, here's how we do it.

To achieve such a high level of perfection in a high-performance audio amplifier, a reliable, fast, efficient amplifier topology is required. The Acurus A2000 series uses high-bandwidth, matched On Semiconductor® output transistors in a fully-discrete class A/B design, input-to-output. Unlike many other discrete topologies in this class of amplifier, our design remains symmetric from the very first current-mirror input stage on through to the output. No op-amps are used in the signal path - only precision, low-noise semiconductors. The result is an audio output that nearly perfectly mirrors the input signal characteristics and dynamics. Soundstage is distinct, broad and detailed. High-frequency transients are crisp and clean. Bandwidth is beyond wide, spanning from less than 10Hz on the low end to more than 70 kHz at the top, well beyond the range of most sources, let alone human hearing. Low-frequencies are reproduced authoritatively due in no small part to the big power supply which features a massive toroidal transformer and 46,000 microfarads of power supply capacity even in the basic A2002. The 5 and 7-channel models more than double that capacitance. In fact, all A2000 series amplifiers are capable of delivering current peaks to a speaker load exceeding 18 Amps!

However, we don't feel it's not enough for engineers to build a unit which measures well on the test bench. To make every one of these amplifiers sound as good in your home as the very first ones we hand-built in the lab, we have the circuit boards stuffed and inspected by both hand and machine and final assemble each here in the USA in our factory in southern Indiana. We take advantage of a manufacturing environment designed to make not only high-performance audio products, but also precision devices for demanding medical, military and communications customers. Within our products, carefully inspected printed circuit boards feature thick copper layers and are populated with tight-tolerance

(1%) resistors and film capacitors throughout the signal path. Internal wiring is done by hand using high-temperature and Teflon-coated materials. Transformers are custom-wound to our specifications and made in North America with virgin materials.

The solid look of these amplifiers should come as no surprise. The Acurus A2000 series metalwork is done right in Indiana at some of the same precision metal suppliers building certified componentry for IRL (Indy Racing League) cars. Thick-gauge steel forms the framework for the Acurus-standard anodized Aluminum alloy faceplate, top cover and side heat sinks. The frame is powder-coated white to protect it, to make assembly easier and to make the rear panel easier to read during installation in the typical dimly-lit home AV equipment rack. Unlike most of our competitors, externally mounted heat sinks on all models draw heat away from the interior of the chassis using natural convection most effectively, especially in a rack mount scenario. Custom rack ears make system-integration smooth. Mechanical details are important to us - down to the laser-etched logo and model information on the custom-tooled front panel. Even the power switch was designed from the ground-up by Acurus engineers for long-life, good illumination and a solid feel.

When an Acurus amp initially "comes to life" on the assembly line, we make sure it's first days are its most difficult. Once an amplifier is fully-assembled and quality-checked, it is tuned on the assembly line for optimal performance prior to burn-in, tested and then re-tested once again. Our tough burn-in tests not only prepare the amplifier for first use but also expose it to worst-case operational loads, exceeding the most challenging home environments we can imagine. Our goal is to make sure each amplifier we build lasts as long as legacy Acurus amps built more than a decade ago.

While we're proud of what we achieved with the Acurus A2000 series, we recognize our own human bias can easily get in the way of objectivity and fair comparisons. That's why we chose to engage the assistance of THX to certify our Acurus A2000 series to their stringent Ultra2 requirements. THX Ultra2 is designed for home audio enthusiasts that demand peak performance. It offers

uncompromised playback of multi-channel movies, music and games. It incorporates new features and power requirements for premium Home Theater receivers, pre-amplifiers, power amplifiers and speakers capable of distributing an optimal soundstage across wide viewing areas in dedicated Home Theaters. We're happy to report that our amplifiers pass with flying colors.

But in today's world, you may point out, it's not enough to simply deliver great sound. You want control of the experience. We recognized that too when we designed the Acurus A2000 series. That's why we developed an entirely new technology which gives you total control of your system - using our built-in proprietary web control. With our web control, you can monitor and control all system features and functions through an existing home network, all with a smart phone, computer, or almost any device with a web browser. No need for yet another IR remote on the coffee table. We put the control where you want it - in your hands and in your pocket. As future updates become available, these amps can be updated in both software and hardware. There are no apps to download since all the software, including the user interface, resides in the unit itself.

So, see your local dealer and ask for a demo to understand why we feel, and others agree, that the Acurus A2000 series delivers an audio experience unmatched by any others in its class.



Acurus A2000 Series – 2012 CES Innovations Award Honoree – Audio Components Category

WARRANTY

U.S. and Canada:

The Warranty below is valid only for sales to consumers in the United States or Canada.

The manufacturer warrants this product to be free from defects in materials and workmanship (subject to the terms set forth below) for a period of five (5) years from the date of purchase. During the Warranty period, the manufacturer will repair or replace (at the manufacturer's option) this product or any defective parts.

To obtain technical support and/or warranty service, you may either: (a) contact the authorized Acurus dealer from which you purchased this product or (b) call INDY AUDIO LABS at 1-866-559-5113 (toll free) or (c) email INDY AUDIO LABS support at support@indyaudiolabs.com. If you choose to call INDY AUDIO LABS directly we strongly suggest that you choose the technical support option as the majority of customer problems can be solved over the phone. If technical support is unable to solve the problem, they will advise as to whether the preferred route to obtain warranty service is to return the product to the INDY AUDIO LABS authorized dealer from which you purchased the product or to return the product directly to the manufacturer, freight paid, for repair. If returning the product you will need to obtain a Return Authorization from Indy Audio Labs and ship this product in either its original packaging or packaging affording an equal degree of protection.

Proof of purchase in the form of a bill of sale or receipted invoice (which is evidence that this product is within the Warranty period) must be presented or included in order to obtain Warranty service.

This Warranty is invalid if (a) the factory-applied serial number has been altered or removed from this product or (b) this product was not purchased from an INDY AUDIO LABS authorized dealer. You may call 1-866-559-5113 (choose the INDY AUDIO LABS customer service option) to confirm that you have an unaltered serial number and/or that you purchased from a INDY AUDIO LABS authorized dealer.

This Warranty is only valid for the original purchaser and will automatically terminate prior to expiration if this product is sold or otherwise transferred to another party.

This Warranty does not cover cosmetic damage or damage due to misuse, abuse, negligence, acts of God, accident, commercial use or modification of, or to any part of, the product. This Warranty does not cover damage due to improper operation, maintenance or installation, or attempted repair by anyone other than the manufacturer or an INDY AUDIO LABS dealer which is authorized to do INDY AUDIO LABS warranty work. Any unauthorized repairs will void this Warranty. This Warranty does not cover product sold AS IS or WITH ALL FAULTS.

REPAIRS OR REPLACEMENTS AS PROVIDED UNDER THIS WARRANTY ARE THE EXCLUSIVE REMEDY OF THE CONSUMER. THE MANUFACTURER SHALL NOT BE LIABLE FOR ANY INCIDENTAL OR CONSEQUENTIAL DAMAGES FOR BREACH OF ANY EXPRESS OR IMPLIED WARRANTY ON THIS PRODUCT. EXCEPT TO THE EXTENT PROHIBITED BY LAW, THIS WARRANTY IS EXCLUSIVE AND IN LIEU OF ALL OTHER EXPRESS AND IMPLIED WARRANTIES WHATSOEVER, INCLUDING BUT NOT LIMITED TO, THE WARRANTY OF MERCHANTABILITY AND FITNESS FOR A PRACTICAL PURPOSE.

Applicable Territories: Some states and foreign territories do not allow the exclusion or limitation of incidental or consequential damages or implied warranties so the above exclusions may not apply to you. This Warranty gives you specific legal rights, and you may have other rights, which vary from state to state and territory to territory. The warranty on this product if it is sold to a consumer outside of the United States or Canada shall comply with applicable law and shall be the sole responsibility of the distributor that supplied this product. To obtain any applicable warranty service, please contact the dealer from which you purchased this product, or the distributor that supplied this product.

about acurus and indy audio labs

Acurus and Aragon are wholly owned brands of Indy Audio Labs. Acurus was originally founded in 1993 by Mondial designs as a more affordable alternative to its, by then, critically acclaimed Aragon brand.

Indy Audio Labs was founded in late 2008 by three audio engineers and a physicist who saw a vision for an affordable set of home entertainment products which bring together professional-grade audio performance, state-of-the-art control and connectivity, and simplified access to today's content sources.

Like its predecessor, Mondial, Indy Audio Labs designs and manufactures all of its audio components in the USA using custom fabricated parts and assemblies. Indy Audio Labs prides itself on remaining true to the original mission of Acurus – delivering “Accuracy from the USA”.

acurus

INDY
AUDIO)))LABS

www.indyaudiolabs.com

5225 Exploration Drive

Indianapolis, IN 46241

T 866.559.5113

F 866.719.8516

E info@indyaudiolabs.com