

Stereo Sound

Stereo Sound

Grand Prix

GRAND PRIX 2022

2022 2023

527 selections BEST

BUY COMPONENTS

Stereo Sound

GRAND
PRIX
2022

BEST BUY

COMPONENTS
'22-'23

2 0 2 3
WINTER
No. 225



50th year answer.

The history of creating high-end audio components has reached half a century since its founding in 1972. We pay particular attention to every corner of every circuit and every single component to achieve the highest level of sound quality. The sound creation we have continued since our founding has culminated in the 50th anniversary limited production model ML-50. And that's the answer from Mark Levinson, looking ahead to the sound 50 years from now.

50

mark
LEVINSON



Mark Levinson 50th Anniversary Model
MONAURAL POWER AMPLIFIER
ML-50

Standard price ¥5,500,000 (¥6,050,000 including tax)/pair ★Limited production



Harman International Co., Ltd.
<http://marklev.harman-japan.co.jp/>



50 mark
Levinson

ML-50
MONAURAL AMPLIFIER
Limited Edition



WILSON AUDIO



New!!

4 way 5 drivers system

ALEXX V

Standard color: ¥29,000,000/pair (tax excluded) ¥31,900,000/pair (tax included)
Upgrade color: ¥30,000,000/pair (tax excluded) ¥33,000,000/pair (tax included)

The photo is an image of Ivory (upgrade color).





audel
art loudspeakers



New!!

2 way 2 speakers system

U-Basik 5/8

Walnut: ¥390,000/pair (tax excluded) ¥429,000/pair (tax included)

Mosaic/Tribal: ¥430,000/pair (tax excluded) ¥473,000/pair (tax included)

Options: Stand ¥160,000/pair (tax not included) ¥176,000/pair (tax included)

Grill cover ¥30,000/pair (tax not included) ¥33,000/pair (tax included)

The photo is an image of walnut.

Stella Inc.

Stella Co., Ltd.

51-10 Nakamaru-cho, Itabashi-ku, Tokyo 173-0026 Tel. (03)3958-9333 Fax. (03)3958-9322 <http://www.stella-inc.com/e-info@stella-inc.com>



Made in
Switzerland

G

GOLDMUND
SWISS MADE



New!!

Stereo Preamplifier

MIMESIS 37S Nextgen

¥3,200,000 (tax not included) ¥3,520,000 (tax included)



YPSILON



Made in Greece



New!!

Monoblock Power Amplifier
Aelius 2 Mono SE
(Silver Edition)

¥7,800,000/pair (tax not included) ¥8,580,000/pair (tax included)

Stella inc

Stella Co., Ltd.

51-10 Nakamarucho, Itabashi-ku, Tokyo 173-0026 Tel. (03)3958-9333 [Main] Fax. (03)3958-9322 <http://www.stella-inc.com/> e-info@stella-inc.com



New!!

SACD/CD/Transport

D1.5

¥4,900,000(tax not included) ¥5,390,000(tax included)

New!!

D/A Controller

C1.2

¥5,100,000(tax not included) ¥5,610,000(tax included)

Upgrade price from C1 to C1.2: ¥580,000 (tax excluded) ¥638,000 (tax included)

For C1 owners: There is an upgrade program from C1 to C1.2. Please contact us for details.



Made in
Switzerland

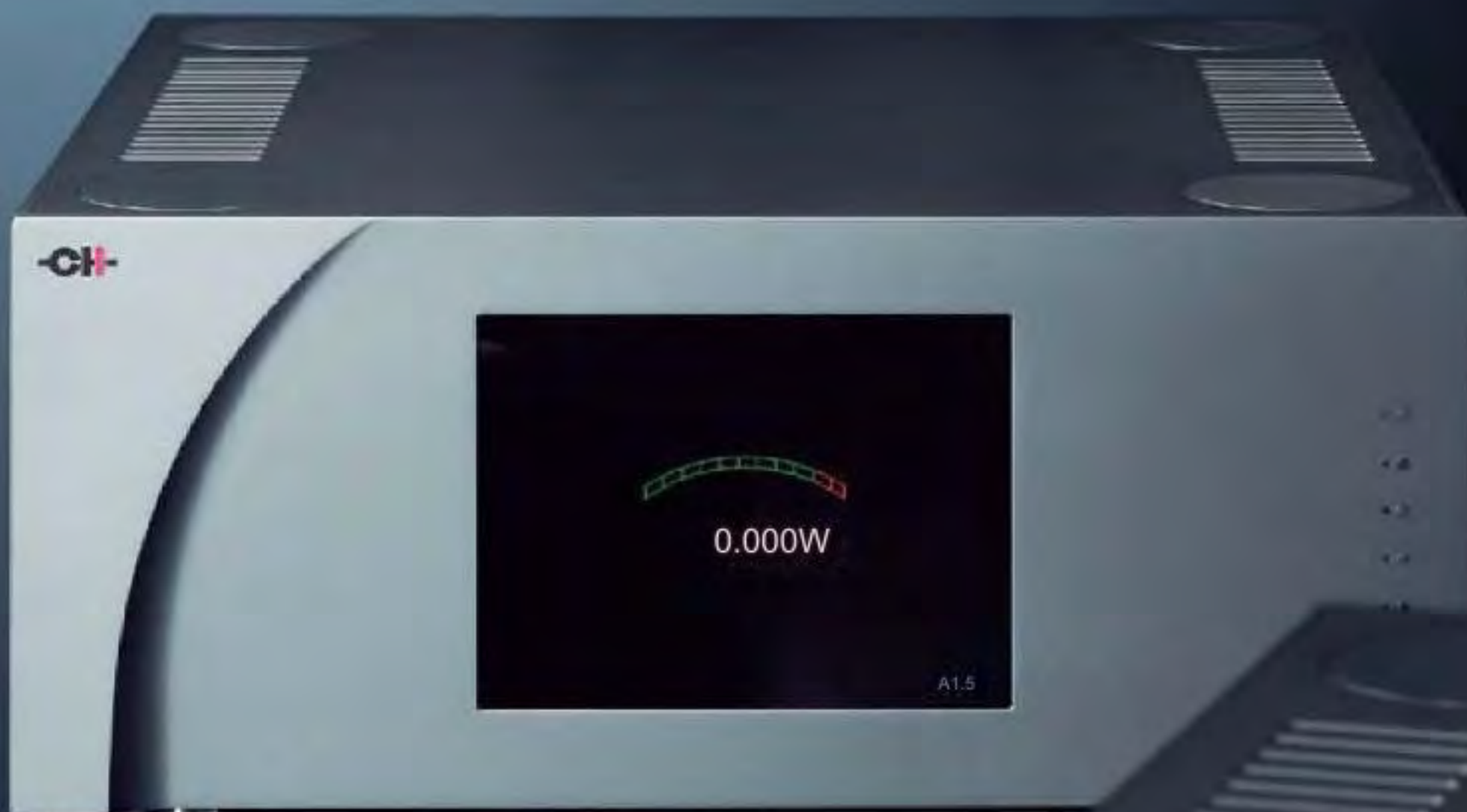

Two-channel Power Amplifier

A1.5 Mono

¥9,300,000/pair (tax not included) ¥10,230,000/pair (tax included)

Zephyr inc
Zephyr inc

Zefan Co., Ltd.

51-10 Nakamaru-cho, Itabashi-ku, Tokyo 173-0026 Tel. (03)5917-4500 Fax. (03)3958-9324 <http://www.zephyrn.com/> e-info@zephyrn.com

Distributed by STELLA Group



New!!

Speaker System

Mingus Quintet 2

¥8,500,000/pair (tax not included) ¥9,350,000/pair (tax included)

There is also a Statement Edition with all internal wiring upgraded to Jorma Design Statement.

Mingus Quintet 2 Statement Edition

¥10,000,000 (tax not included) ¥11,000,000 (tax included)



 MARTEN



New!!

Speaker System

Oscar Trio

¥1,400,000/pair(tax not included) ¥1,540,000/pair(tax included)

 MARTEN

Zephyrn inc.
Zephyrn inc.

Zefan Co., Ltd.

51-10 Nakamaru-cho, Itabashi-ku, Tokyo 173-0026 Tel. (03)5917-4500 Fax.(03)3958-9324 <http://www.zephyrn.com/> e-info@zephyrn.com

Distributed by STELLA Group

35TH

ANNIVERSARY

1987-2022



ESOTERIC

– Revolution Begins. –

Our first turntable to commemorate our 35th anniversary. T1 embodies our spirit, which has remained unchanged since our founding in 1987. "Revolution."

There's a board there, so turn it.

When it comes to turning things accurately, we are second to none.





Grandioso C1X
line stage preamp

This quote describes what a brand that strives to innovate should be. Take pre/
power transmission to the next level with our unique current transmission "ES-Link Analog".

Don't get carried away and keep pushing
your limits. What lies ahead is an unprecedented exhilaration.

ESOTERIC



- Rising High -

A-kite flies highest when it is facing the wind.

This is not the time to be carried away by the wind.

- Winston Churchill



Grandioso MIX

monoblock power amplifier



Minimal High End Style



The N-05XD is an innovative network DAC preamp that can be described as "integrating the essence of ESOTERIC." The S-05 is a class A stereo power amplifier that incorporates the development results of the Grandioso M1X. Minimal styling with thoroughly refined quality using flagship technology. High-quality sound worthy of talking about high-end.

Welcome to first class.



N-05XD Network DAC/Pri



S-05 Class A stereo power amplifier

ESOTERIC





The best Avantgarde TRIO, we ever made.

This is the second complete technology and platform refresh since the first generation Avantgarde TRIO was introduced in 1993.

Finally, the third generation Avantgarde TRIO is here.



Avantgarde TRIO G3



Space Horn (Twin Rai)



Space Horn (Single Dry)



avantgarde
ACOUSTIC



The ScacoForm shown in the photo shows 6 units. We will invite you to combine the twin drive (left) and single drive (o) into -



C12000
2 Chassis Tube / Solid State Pre Amplifier

McIntosh®

LEGENDARY PERFORMANCE™

... made in U.S.A.



MC3500
Monaural Vacuum Tube Power Amplifier

M

MAGICO



M9

Stereo Sound
Grand Prix
2022



Golden Sound



FINEST MC CARTRIDGES - HANDCRAFTED IN SWITZERLAND



EMT 128
Micro-Tube Precision Phonostage

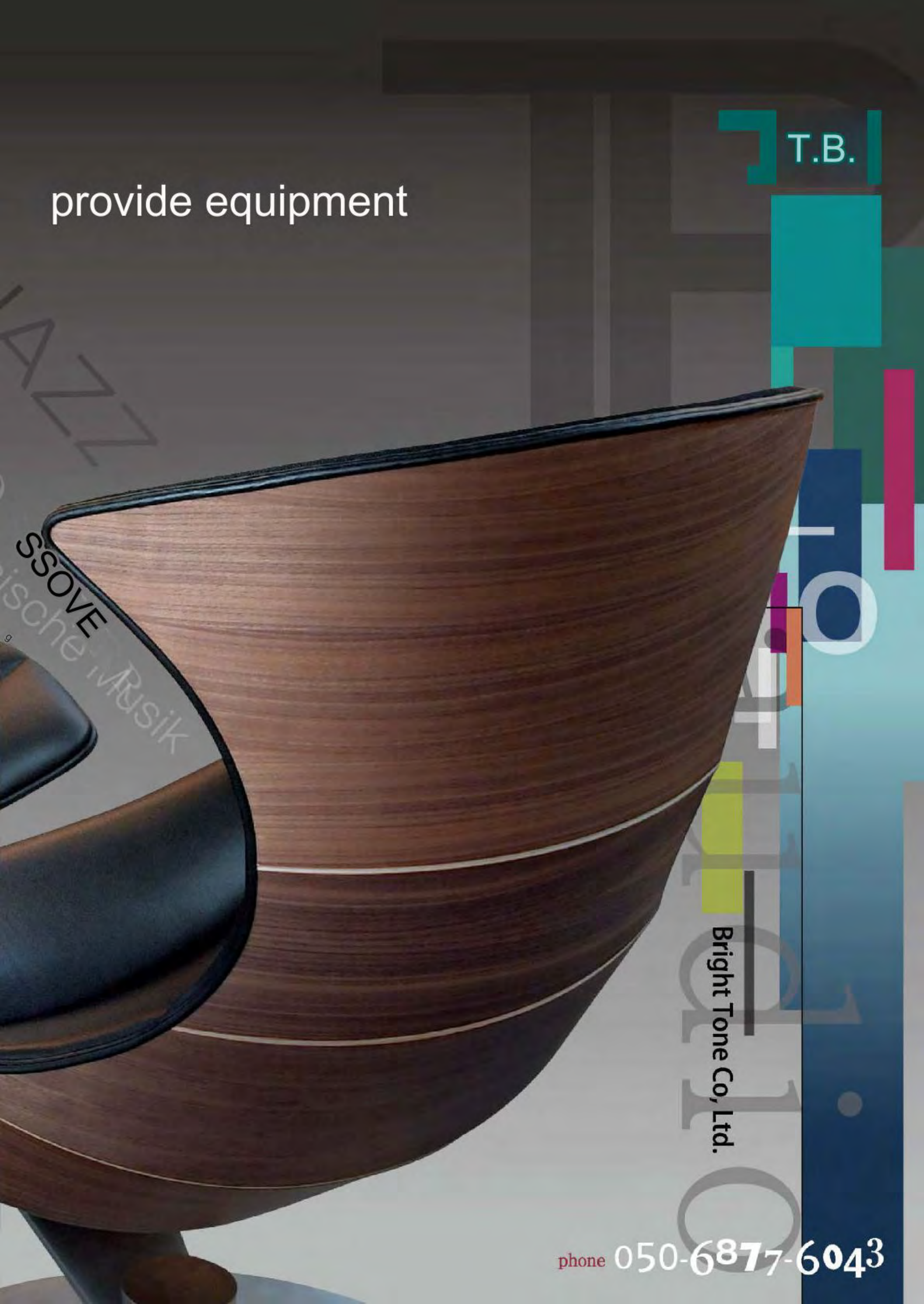

T.B.

provide equipment

Bright Tone Co, Ltd.

phone 050-6877-6043

PLANO

outstanding audio

JAZZ

VOICE

Klassisch Musik

mail : info@bright-tone.com

B
bright-tone.com/

online.stereosound.co.jp/brighttone

The world's first music listening chair
The Gamut Hi-Fi Lobster Chair

Special sound-dampening materials are carefully placed at the right points to enhance the listening experience while maintaining breathtaking aesthetics and luxurious comfort.

Just sit back, relax and enjoy great music.



Roomin's network transport
"U2 MINI" is rich in sonority
and makes music even more
enjoyable. I listened to that
sound and ended up buying a new
one from the "U1 MINI"!



LUMIN



SOM

Now you know how to listen to lossless high-resolution
music on Fire TV 4K MAX! Bit-perfect transmission
is now possible with the Amazon Music app settings



Digital transport is an option that makes use of network
audio in existing systems. We listened to and compared
the charms of Lumin's "U2 MINI" & "U1X," ranging from
the latest DACs to classic models from yesteryear.

Bright Tone

PLANO

Co., Ltd.

bright tone

1-22-3/12 Nishiwaseda, Shinjuku-ku, 169-0051

mail : info@bright-tone.com

JAZZ

Klassische

T.B.

bright-tone.com/

online.stereosound.co.jp/brighttone

usik

Examining all aspects of high-resolution playback in the "ideal audio room."

From the sound features of Roon "U2 MINI" and "U1X" to the effects of Roon Only mode, and even audio-specific chairs!?



"LUMIN P1" & "LUMIN AMP" dramatically improve the sound quality of home audio. With its compact and beautiful design, it provided high-quality entertainment for everything from networks to HDMI devices.



Enjoy the catharsis of audio playback art with Dynamic Audio 5555's "H.A.L.I"! Westminster Lab "Quest" & "Rei" have beautifully depicted the world.





BLADE

Now with Metamaterial
Absorption Technology



sound statement. It is an icon that stimulates every sense.

BLADE

With a bold and impressive presence, BLADE pushes the boundaries of sonic possibilities. The world's first single-parent source speaker featuring KEF's innovative Metamaterial Absorption Technology.

Listen and believe





THE REFERENCE

Now with Metamaterial
Absorption Technology

Remastered details. An icon redefined for the future.

THE REFERENCE

A must have for HiFi enthusiasts. Crafted by masters who set the standard for sound quality, Reference is the benchmark for speakers and sound reproduction. Reference embodies KEF's philosophy and extreme pursuit of perfection. Currently equipped with Metamaterial Absorption Technology (MAT™).



Listen and believe





60 Years of Defining Tomorrow

LS60 Wireless - The future of HiFi sound

A modern design co-designed by Michael Young and the KEF Product Design Team. The latest addition to the KEF family, this iconic, slim construction pushes the limits of audio performance. LS60 Wireless celebrates 60 years of sound innovation and looks to the future of true HiFi experiences.

Supports AirPlay2, Chromecast, Spotify, Tidal, MQA, HDMI, eARC, etc.



Listen and believe



AVALON
ACOUSTICS



ISIS
Signature

TAYO <https://www.taiyoinc.jp/>

INTERNATIONAL, INC.

Taiyo International Co., Ltd.

1F Nihonbashi Grace, 2-12-9 Nihonbashi, Chuo-ku, 103-0027

Ultimate Music Server



The ultimate high-end music server

SGM Extreme

(Made in Netherlands)

Stereo Sound
Grand Prix
2022



IASI
International Audio Society of Japan

Taiyo International Co., Ltd.

NAGRA

SWISS INNOVATION SINCE 1951



REFERENCE ANNIVERSARY TURNTABLE

HIGH DEFINITION PHONO STAGE

NAGRA 70th Anniversary Reference Turntable (Limited to 70 units worldwide)

NAGRA HD Flagship Phono Equalizer Amplifier

TAIYO <https://www.taiyoinc.jp/>
INTERNATIONAL, INC.



The most powerful bookshelf equipped with StepX-JET



ELAL

The first bookshelf model in the Concentro series, the S503,
delivers the world of high-end intelligence that is full of
precision and condensation, which is what ELAC is best at.

Concentro 5 503 ¥1,200,000 pair (¥1,320,000 tax included) BLACK HG/WHITE HG
¥1,300,000 pair (¥1,430,000 tax included) WALNUT HG
Special stand: LS 100 ¥200,000 pair (¥220,000 tax included)



CONCENTRO

ELAC

yukimu

Yukimu Co., Ltd.
1-41-9 Oi, Shinagawa-ku, Tokyo 140-0014 Phone: 03-5743-6202 Fax: 03-5743-0057
<http://www.yukimu.com>

A dream of sound, together.

TRIODE

SPENDOR



British tradition and new
style The sound of Spendor spreads

In addition to the conventional Classic series, A-LINE and D-LINE have also arrived in Japan!



Triode Co., Ltd. 609-3 Fukuroyama, Koshigaya City, Saitama Prefecture 343-0032 TEL. 048-940-3852 FAX. 048-940-3853 <https://www.triode.co.jp>

IASJ
International Audio Society of JAPAN

**Stereo Sound
Grand Prix
2022**



702 S3

With the new 700 Series,
Studio Sound comes home.



Bowers & Wilkins

Burmester

ART FOR THE EAR

216

Stereo Power Amplifier

Something that inherits the will.

"159" embodies the ideal of a power amplifier and has become Burmester's new flagship. I want to convey to as many listeners as possible the expressive power of a different dimension that no one has ever experienced before.

With this as our new mission, Burmester has created a stereo power amplifier. Its name is "216". The compact form inherits the famous 911MkIII, and the performance that condenses the value and power of the 159, as well as the strict design standards that have remained unchanged, and to clearly depict the sound. You will be able to feel Burmester's refined skills and passion.

¥4,350,000(tax not included) ¥4,785,000(tax included)



The ultimate flagship that embodies the ideal.



159 Monaural Power Amplifier

¥40,000,000(pair/tax not included) ¥44,000,000(pair/tax included)

Monaural power amplifier "159". It is a new flagship from Germany's Burmester, which has been pursuing a unique amplifier aesthetic and philosophy, and it has been 7 years in the making. The most powerful power supply section in Burmester history. The first feature in the history of power amplifier development is multi-step variable damping factor. This is Burmester's largest-scale amplifier design in history, which can be compared to a majestic temple of sound. All of them faithfully embody the amplifier ideals envisioned by founder Dieter Burmester, who sadly passed away during the project, and present a vision of the future of power amplifiers.

Burmester
ART FOR THE EAR



Sonus faber.

Masterpiece musicality inherited using the latest technology. HERITAGE



MINIMA AMATOR II

¥560,000 (pair/excluding tax) ¥616,000(pair/tax included)



ELECTA AMATOR III

¥1,380,000 (pair/excluding tax) ¥1,518,000 (pair/tax included) *Exclusive stand included

The Electa Amator III inherits the spirit and musicality of the Electa Amator, which changed the history of speakers. The Minima Amator II is the successor to the Minima Amator, which expanded new horizons for small speakers.

The two HERITAGE collections are a new generation of masterpieces in which the technical elements that built Sonus Faber's history have been updated and refined one by one using today's technology.

Sonus faber.

OLYMPICA NOVA The future of speakers is reflected in its innovative form.



OLYMPICA NOVA III

¥1,550,000 (pair/excluding tax) ¥1,705,000 (pair/tax included)



OLYMPICA NOVA I

¥850,000 (pair/tax included) ¥935,000 (pair/tax included)

OLYMPICA NOVA V

¥2,100,000 (pair/excluding tax) ¥2,310,000 (pair/tax included)



While learning a lot from the techniques of ancient musical instrument craftsmen, Sonus Faber has flexibly introduced the latest technology, opening up new possibilities for speakers. This respect for both tradition and innovation is reflected in the OLYMPICA NOVA collection's classic yet innovative form and advanced acoustic design, which exquisitely combines wood and metal.

A sense of the reality of the music engraved on the record Brings out the artist's passion
A new flagship that uses a diamond cantilever
MC cartridge PP-5000

New

MC Cartridge PP-5000 1,350,000 yen (tax excluded) 1,485,000 yen (tax included)



Phasemation Nobuyuki Suzuki



MC Cartridge PP-2000

550,000 yen (tax not included) 605,000 yen (tax included)

Passive attenuator type
controller with +6dB amplification function
A new era preamplifier! Finally here!

New

Control Meister CM-2200 1,800,000 yen (tax not included) 1,980,000 yen (tax included)



MC Stepup Transformer T-2000

990,000 yen (tax excluded) 1,089,000 yen (tax included)



Phono Amplifier EA-2000

3,300,000 yen (tax excluded) 3,630,000 yen (tax included)



Control Meister CM-2200

1,800,000 yen (tax not included) 1,980,000 yen (tax included)



Monaural Power Amplifier MA-2000 1,500,000

yen (1 unit/excluding tax) 1,650,000 yen (1 unit/tax included)



"Create history."

"Pure Class A"

Monophonic power amplifier A-300

edition of the "50th Anniversary Model" Pure
Class A drive monophonic power amplifier
A-300 was born. Fifth

The latest instrumentation amplifier is made into a
completely discrete circuit to achieve
the highest SN ratio in history.

the output stage is equipped with a "power MOS FET"

A total of 20 parallel push-pull configurations,

efficiency toroidal transformer.

capacity filter capacitor and large high

1C (music signal) large

Enables large output. 1000W/

amplifier through the accumulation of evolution and tradition.

pursues the ideal form of power

Accuphase always continues to take on challenges. The A-300



**Stereo Sound
Grand Prix
2022**



new product

Pure class A monophonic power amplifier A-300

Suggested retail price 1,350,000 yen (1,485,000 yen including tax)/1 unit.

Pure class A stereo power amplifier

A-75

Suggested retail price 1,300,000 yen (1,430,000 yen including tax)



Pure class A stereo power amplifier

A-48

Suggested retail price 750,000 yen (825,000 yen including tax)



Pure class A stereo power amplifier Suggested

A-36

retail price: 410,000 yen (451,000 yen including tax)

*For catalog requests, please contact Accuphase Co., Ltd. Advertising Department, 2-14-10
Shinshikawa, Aoba-ku, Yokohama 225-8508

JASI
International Audio Society of Japan

TEL: (045-901)-2771 (Main) FAX: 045-901-8959
<https://www.accuphase.co.jp/>

"Tradition and Innovation"

Comfortable driving ability

Stereo power amplifier P-7500

AB class operation

The P-7500, the highest-ranking stereo power amplifier, was born.

The circuit method is

Introducing a "low noise instrumentation amplifier"

High efficiency large toroidal transformer and

Powerful power supply circuit with large capacity filter capacitor.

Equipped with a "high power transistor"

10 parallel push-pull drive power unit in the output stage.

300W/100V 300W/40V

900W/20 (music signal only)

Achieves high output power amplifier.

silence, and drives all speakers cheerfully.

overflows with a sense of energy in

It has a rich musicality.

A new generation stereo power amplifier.

possible. *Using two P-7500s.

Bridge connections and bi-amp connections are also



new product

Stereo power amplifier

P-7500

Suggested retail price 1,350,000 yen (1,485,000 yen including tax)



Stereo power amplifier P-4500

Suggested retail price: 550,000 yen (605,000 yen including tax)



monophonic power amplifier **M-6200**

Suggested retail price: 900,000 yen (990,000 yen including tax)/1 unit

"Skills passed down"

AAVA equipped preamplifier

C-3900 & C-2900

Following the highest peak C-3900

Add C-2900

This is the birth of a new lineup.

Adopts Balanced AAVA

From input terminal to output terminal

Fully balanced configuration

Achieves volume control.

Input amplifier, VI conversion, IV conversion, output amplifier

the delicacy of minute signal transmission

configuration of all circuits to realize

I pursued it thoroughly. Discrete

craftsmanship and beauty and

challenges, striving for the ultimate in

Accuphase continues to take on

sophistication born from the accumulation of evolution and tradition.

*Playing analog records

C-2150: Optional expansion "AD-50"

C-2450: Optional expansion New product "AD-2900"

C-2900: Optional expansion New product "AD-2900"

C-3900: Sold separately "C-47"



New

product Precision
Stereo Preamplifier Suggested

C-2900

retail price: 1,400,000 yen (1,540,000 yen including tax)



Precision Stereo
Preamplifier Suggested

C-3900

retail price 2,000,000 yen (2,200,000 yen including tax)



Precision
Stereo control center Suggested
retail price 750,000 yen (825,000 yen including tax)

C-2450



stereo control center **C-2150**
Suggested retail price 500,000 yen (550,000 yen tax included)

"Tradition and advanced techniques"

Separate type SA-CD/CD player

SA-CD Transport DP-1000

Digital Processor DC-1000

Inheriting all past know-how

model commemorating the 50th anniversary of our founding.

This is the birth of DP-1000/DC-1000. This is the third

The SA-CD/CD drive of DP-1000 is

further improving the heavy-duty

an anti-vibration, damping, and low center of gravity mount design,

The digital signal engraved on the disc has been realized with

structure and bringing out the highest purity.

The DAC of DC-1000 is

Drive 8 circuits of "ES9038PRO" in parallel

The original "MDS method D/A converter"

accuracy and a unique "ANCC" in the IV conversion circuit

Equipped with extremely high conversion

It enables low distortion and low noise.

Depicts music information from all digital

sources in its entirety

Creating history in high-end digital audio.



new product

Precision SA-CD Transport DP-1000

Suggested

retail price 1,300,000 yen (1,430,000 yen including tax)

New

product Precision MDS Digital Processor DC-1000 **Suggested**

retail price 1,300,000 Yen (1,430,000 yen including tax)



Precision MDS SA-CD player **Suggested**
retail price 1,270,000 yen

DP-750
(1,397,000 yen including tax)

new product

CD player DP-450 **Suggested**
retail price: 390,000 yen (429,000 yen including tax)

MDS SA-CD player DP-570 **Suggested**
retail price 680,000 yen (748,000 yen including tax)

“Complete pre-main lineup

Evolved “AAVA”

Integrated amplifier E-4000

“AAVA” that achieves even lower noise

Equipped with “ANCC” in

Introducing the E-4000.

The output stage uses a “bipolar transistor”

4 parallel push-pull drive,

Large toroidal transformer and

large capacity filter capacitor

Powerful power supply

Achieved high output of 180W/8, 260W/4C.

Significant improvement in damping factor, etc.

E-4000 has been refined using cutting-edge

In pursuit of ideal speaker drive, the

technology and invites you to a rich sound space.

*By adding an optional board

performance · “AD-50” Analog record performance
· “DAC-60” High-resolution



new product

Integrated stereo amplifier E-4000 Suggested retail price: 630,000 yen (693,000 yen including tax)



240W/ch(80)
Integrated Stereo Amplifier E-5000 Suggested retail price 950,000 yen (1,045,000 yen including tax)

Pure A class 50W/ch (BQ)
Integrated stereo amplifier E-800 Suggested retail price 1,030,000 yen (1,133,000 yen including tax)

Integrated stereo amplifier E-380 Suggested retail price 480,000 yen (528,000 yen including tax)

Pure A class 30W/ch(82)
Integrated stereo amplifier E-650

90W/ch(80)
Integrated Stereo Amplifier E-280

Suggested retail price 760,000 yen (836,000 yen including tax) Suggested retail price 360,000 yen (396,000 yen including tax)

"Reach to the top.

Top stereo phono amplifier

Birth of C-47

The C-47 brings together the best of analog technology
Equipped with MC balanced input terminal
From input to output
Achieved full balanced transmission.

Designed exclusively for MC/MM
Equipped with a head amplifier with balanced input/output configuration.
For the input element

"For MC: Low noise bipolar transistor"
Adopts "Low noise JFET for MM"
Achieves high signal-to-noise ratio and low distortion rate.
This output

Equalize the balanced signal
Input to equalizer amplifier.
Various cartridge tastes and
possible. The charm of traditional analog discs
High-quality playback is



Stereo Phono Amplifier Suggested **C-47**
retail price: 650,000 yen (715,000 yen including tax)



Moving coil type phono cartridge **AC-6**

Suggested retail price: 370,000 yen (407,000 yen including tax)

The AC-6 is a model that uses the best materials to give its tones a deep flavor and charm, aiming to be the ultimate in record playback.

- Made of high-hardness machined titanium material •Cantilever: Solid boron •Stylus: Semi-line contact type •Magnet: Neodymium N50 •Coil \$50μmOFC•Output voltage 0.4mV (1kHz)•Internal impedance, 1.80(DCR) •Appropriate stylus pressure 1.9-2.2g (2.0g center) •Self weight 13.5g

For catalog requests, please contact Accuphase Co., Ltd. Advertising Department: 2-14-10

Shinshikawa, Aoba-ku, Yokohama 225-8508

JASJ
JAPAN ASSOCIATION OF STEREO
JAPANESE AUDIO SOCIETY (JASJ)

TEL: 045-901-2771 (Main) FAX: 045-901-8959

<https://www.accuphase.co.jp/>



Hailey 2.2

Loudspeaker System



AccAinc.

T:03-5785-0661 ■ F:03-5785-0662

www.accainc.jp





The pedigree of the flagship that has been cultivated——

A new piece of digital media player.

NEW



SUPER AUDIO CD PLAYER

D-07X

Suggested retail price: 825,000 yen
(excluding tax: 750,000 yen)



■Luxman Co., Ltd.

1-3-1 Shin-Yokohama, Kohoku-ku, Yokohama-shi, Kanagawa 222-0033

TEL:045-470-6991 FAX:045-470-6997 www.luxman.co.jp

To request a catalog, please fill in the model name and magazine name.



The free warranty period for this product after the application of the "Premium Extended Warranty" is 3 years.

LUXMAN



Completely sensitive, fully emotional -
Abundant analog, eternal time played by the finest players.

NEW



BELT DRIVE ANALOG PLAYER

PD-191A

Suggested retail price 990,000 yen
(excluding tax 900,000 yen)



*This product does not include a phono cartridge or analog record.

The free warranty period for this product after the application of the "Premium Extended Warranty" is 3 years



Lux manhole
Information



New Generations

 www.luxman.co.jp/focalspeakers/

■Luxman Co., Ltd.

1-3-1 Shin-Yokohama, Kohoku-ku, Yokohama, Kanagawa
222-0033 TEL: 045-470-6991 FAX: 045-470-6997 www.luxman.co.jp/
To request a catalog, please fill in the model name and magazine name.



Luxman Co., Ltd. handles FOCAL's HOME category (Hi-Fi speakers/Hi-Fi headphones) products.

FRANCO SERBLIN



A beautiful speaker philosophy that continues to live on.

We design speakers as musical instruments that breathe life into wood and play music beautifully. Franco Serbrin's speaker philosophy, which changed history, has been passed down through generations, including the majestic sound of the Ktema and the sophisticated expressive power of the Accordo, as well as Massimiliano Fabella's vivid design and Accordo Essence. I am.

Ktema ¥4,500,000 (pair/excluding tax) ¥4,950,000 (pair/tax included) Accordo ¥1,300,000 (pair/excluding tax) ¥1,430,000 (pair/tax included)
Accordo Essence ¥1,950,000 (pair/tax included) ¥2,145,000 (pair/tax included)

Ark Gioia

Arc Gioia Co., Ltd.

4th floor, Shoshinsha Holdings Building, 1-1-7 Otowa, Bunkyo-ku, Tokyo 112-0013 03-6902-0480 www.arkgioia.com

esteron(

Model YB MkII



Polishing the sound, MkII.

An elegant yet rigid closed cabinet based on a marble-based composite material and an acoustically thoughtful unit arrangement. This amazing methodology leads to a form of extremely clear sound. The Esteron Model YB, which captivated the world, is now in a new generation.

¥2,720,000 (pair/excluding tax) ¥2,992,000 (pair/tax

■ included) left: Matte Black center: Gloss White ●right: Gloss Black

- estelon -

XB Diamond MkII



A beautiful, new soundscape.

The purity of sound achieved by an advanced non-resonance cabinet made by elegantly molding composite materials such as marble powder into one piece. The diamond dome tweeter inherited from the flagship "Forza", and the ceramic inverted dome creates a texture of sound that interweaves mid and low frequencies.

And the sense of volume due to the rear bass reflex system. A new dimension of esteron, "XB Diamond MkII".

¥5,800,000 (pair/excluding tax) ¥6,380,000 (pair/tax included)

- Gloss Cobalt Blue
- Gloss Black/Matte Black
- Gloss White/Matte White

Ark Gioia

Arc Gioia Co., Ltd.

4th floor, Shoshinsha Holdings Building, 1-1-7 Otowa, Bunkyo-ku, Tokyo 112-0013 03-6902-0480 www.arkgioia.com

Reed[®]
For painting on silence



Tangential tone arm that accurately traces to the innermost circumference of the record groove

Reed 5A

¥1,595,000~(tax included)

Flagship turntable equipped with a quartz lock-controlled double motor that can switch between friction (idler) and belt drive.

Muse 3C

¥4,290,000 (tax included)

Rud
Muse 3C

eilex

Alare

Tapered transmission line,
paper/carbon composite woofer, ceramic
mid driver, diamond
tweeter, everything
is exquisitely fused together.
Debut work



**Stereo Sound
Grand Prix
2022**



Remiga 2

¥12,980,000 (pair/tax included)

eilex irex Co., Ltd.

Tel: 042-312-2887

www.eilex.jp

E-mail: info@eilex.jp

The ideal amplifier that Yoshiro Uesugi aimed for The Uesugi amplifier entrusted to Nobuo Fujiwara
Our company, which underwent a new structure in 2011, has celebrated its 50th anniversary with your support.

We will continue to search for sounds that allow us to share the excitement of music with everyone.

U-BROS-280R 1,078,000 yen (tax included) Vacuum tube stereo line pmp
The ultimate dual monaural construction in Uesugi history using mechatronics technology



**Stereo Sound
Grand Prix
2020**



Wireless console U-BROS-280RM included



U-BROS-220R 715,000 yen (tax included) Optical cartridge compatible vacuum tube phono amplifier

Pursuing sound quality and functions that expand the appeal of analog disc playback



**Stereo Sound
Grand Prix
2021**



Midoriyama Building, 1-5-3 Miwa Midoriyama, Machida City, Tokyo 195-0055
TEL. 044-712-4632 FAX. 044-712-4635 info@uesugi Lab.co.jp

Uesugi Research Institute Ltd.

In July 2020, the head office and Yokohama office were integrated.

We are currently recruiting technical staff. Please apply by email.

uesugi 50th

UESUGI 50th anniversary model

U-BROS-330AH Circletron output vacuum tube push-pull power amplifier

Uesugi power amplifier technology 300B push-pull output 30W

The photo shows an example of G-330 installed

**Stereo Sound
Grand Prix
2022**



U·BROS-330AHWE

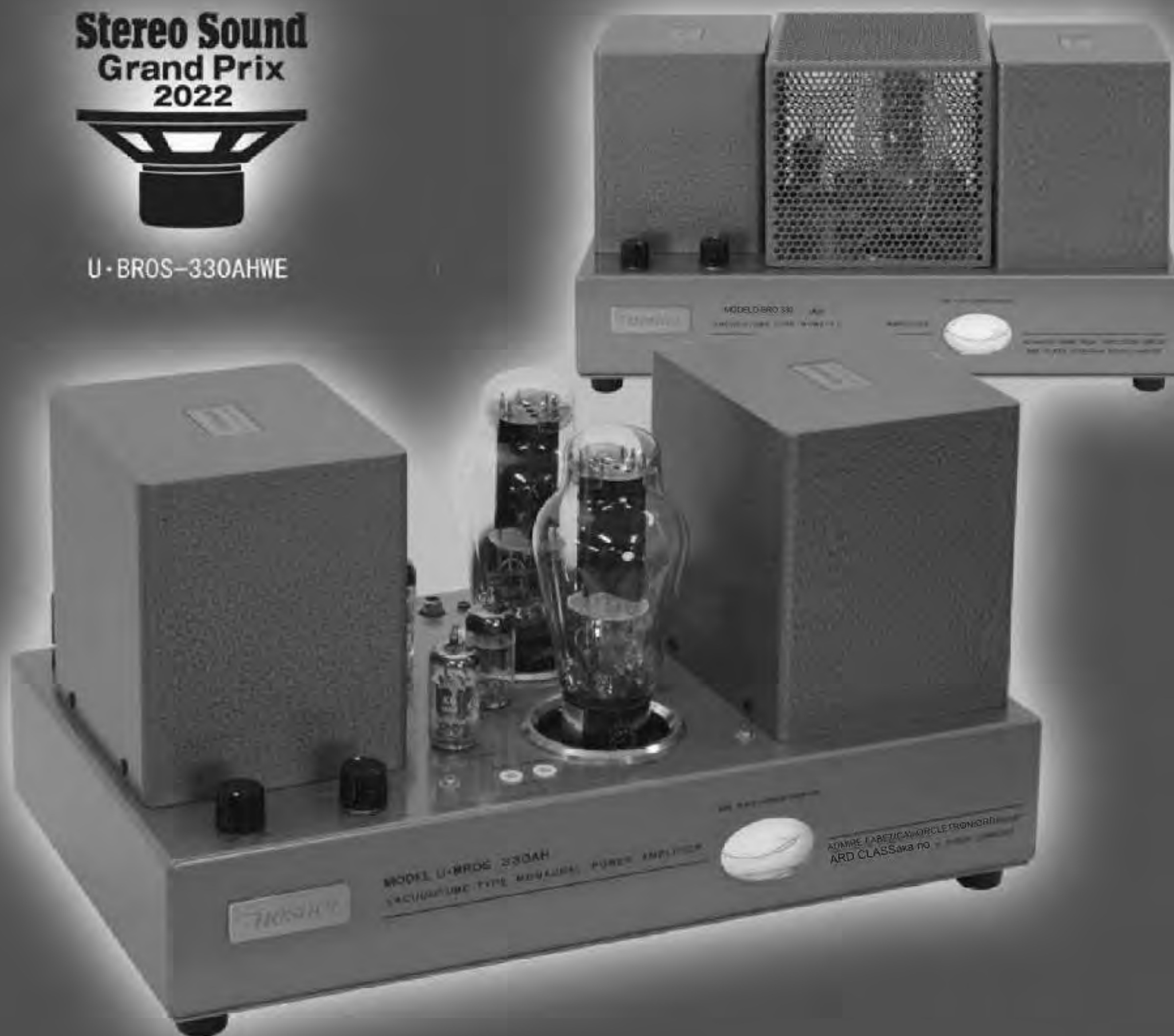

U-BROS-330AHWE 2,310,000 yen (stereo pair tax included) WE company 300B equipment

U·BROS-330AHPS 2,035,000 yen (stereo pair tax included) PSVANE 300B equipment

U·BROS-330AHL 1,815,000 yen (stereo pair tax included) 300B None

Dedicated vacuum tube cover

G-330

44,000 yen (stereo pair tax included)



to revive that soul



METIS

Music with Emotion that Transmits its Influence through the System



**Stereosound
Grand Prix
2020**



Preamplifier P-3

¥1,760,000 (tax included) Premium Silver/Premium Black



**Stereosound
Grand Prix
2022**



**New
Monoblock Power Amplifier M-3**

¥1,650,000 (tax included) Premium Silver/Premium Black

METIS

M-3 x2, P-3 System total price ¥5,060,000 (tax included)

Z E U S

SOULNOTE ZERO LINK ULTIMATE SYSTEM

Stereo Sound
Grand Prix
2021



D/A Converter **D-3**
¥1,848,000 (tax
included) Premium Silver/Premium Black



Network Transport **Z-3**
¥1,166,000 (tax
included) Premium Silver/Premium Black



10MHz Clock Generator **X-3**
¥385,000 (tax
included) Premium Silver/Premium Black



Clock Cable **RCC-1**
¥132,000 (tax included)

ZEUS D-3, Z-3, X-3, RCC-1 System total price ¥3,531,000 (tax included)

Acoustic Grove System **AGS**

ANKH
Acoustic Grove System

SYLVAN
Acoustic Grove System

ANKH-III (small type)



ANKH-III DT 66W×11D×30H (cm)

This is a small size product designed to provide the effect of AGS even in rooms where there is no space to install ANKH or SYLVAN. Placing it in front of a display or audio rack will reduce the effects of reflections and deepen the sense of depth in the sound field.

ANKH-VI (floor type)



ANKH-VI FL66 60W×60D×12H (cm)
FL99 90W×90D×12H (cm)

Install it on the floor, where the effect of reflected sound is greater than on walls or ceilings. Sound reflected from the floor has a major impact on the listening environment, but ANKH-VI scatters and reflects the reflected sound, reducing phase interference with direct sound, resulting in a clearer sound image.

ANKH-IV (ceiling corner type)



ANKH-IV CC 40W×18D×31H (cm)

This product is installed in the ceiling corner, which is an acoustic spot that greatly affects the indoor sound field. Although it is assumed that it will be placed in the left and right ceiling corners at the front of the room near the speakers, it will also be effective if placed in the left and right ceiling corners at the back of the room.

ANKH-V (ceiling/wall corner type)

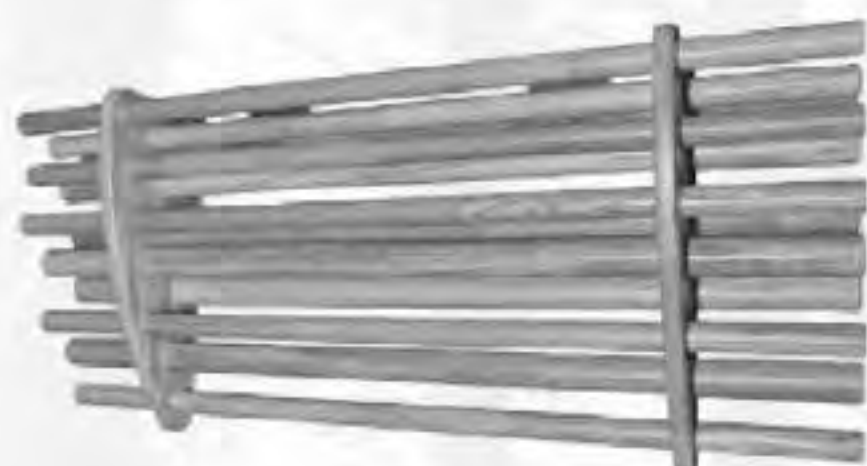

ANKH-V CW 60W×12D×27H (cm)

This product is installed in the spot where the ceiling and wall meet, which determines the quality of the indoor sound field. Although it is intended to be installed in the center of the speaker on the front wall, it will also be effective if installed in any other spot where the ceiling meets the wall.

SYLVAN



SYLVAN Approximately 40W x 32.5D x 140H (cm)

*Right-hand and left-hand versions available

SYLVAN can be placed anywhere and can be easily moved by installing optional casters, allowing you to place it to suit the design and layout of your room. This product is a compact package of AGS's core technologies, and can significantly improve sound field information just by installing it indoors.

* All ANKH-SYLVAN products are patented, designed, and trademarked.

ANKH-SYLVAN awakens the emotion of music

What determines the sound of an audio device
is the sound of the room, room acoustics.

ANKH SYLVAN adjusts the sound in the room
and brings out the true performance of your audio equipment.

ANKH -
I (Flat type)



ANKH-I ST15
60W×23D×150H (cm)

ANKH -
II (corner type)



ANKH-II CO15
40W×40D×150H (cm)

Hybrid ANKH
- I (Flat type)



Hybrid ANKH-I ST-Hy15
60W×23D×150H (cm)

Hybrid ANKH -
II (corner type)



Hybrid ANKH-II CO-Hy15
40W×40D×150H (cm)

*120H-180H (cm) is also available (made to order)
*Custom sizes can also be ordered with a separate estimate.

*120H-180H (cm) is also available (made to order)
*Custom sizes can also be ordered with a separate estimate.

ANKH is a product that condenses the essence of AGS. The flat type ANKH-I is installed along a wall, such as the front wall between the left and right speakers, the side walls on both sides of the speakers, or behind the listening point. ANKH-II is a product that can be installed in both corners of the speaker side or in the rear-corner of the room, and the most effective way to use it is to stack them and install them from the floor to the ceiling without any gaps.

The combination of ANKH-I and ANKH-II is more effective, dramatically improving the sense of spaciousness and depth of the sound field, increasing the resolution from the bass to treble range, and greatly reducing the sense of distortion. Masu.

Hybrid ANKH is a hybrid type product that has a sound absorption space **ク(布)** surrounded by fabric within the same size as a conventional ANKH, and has both "columnar diffusion" and "sound absorption" effects. There are two types available: the flat type Hybrid ANKH-I and the corner type Hybrid ANKH-II. Hybrid ANKH provides a significant improvement in cases where the sound is boomy due to the influence of standing waves, or in rooms with strongly reflective surfaces. In addition, by combining it with the conventional ANKH series, it is possible to create a sound environment that more precisely matches the characteristics of the room.



NIHON ONKYO
ENGINEERING

Japan Onkyo Engineering Co., Ltd. www.noec.co.jp

(Head Office) 1-21-10 Midori, Sumida-ku, Tokyo 130-0021

Sound Space Business Headquarters TEL. 03-3634-3525 FAX. 03-3634-5735

HIBINO
hibino group



Audio Replas
CO., LTD.
REPRODUCE A PRIMARY SOUND

Let the sound be free.
Ultimate room tuning.

An ultra-thin tone panel that will make your room feel bigger just by attaching it to the wall.

The walls of an audio room have a large surface area and always cause inherent reflections, distorting direct sound and spatial vibrations. Reflective surfaces such as window glass reflect a large amount of unique frequencies, resulting in large distortions and distorted natural sounds. Many sound absorbing panels are on the market to counteract these problems. However, although many of these are intended to absorb sound, they also absorb the sound of music, including spatial vibrations that contain important overtones, and the energy of the music is lost.

An ideal wall would absorb standing waves in real time and diffuse reflected sound over a wide band without distortion or energy loss. The ideal thin panel is the Harmonic Diffuser Wall Panel SFW-HD. SFW-HD is an ultra-thin room tuning panel with a thickness of 11 mm that was originally developed by Audio Replus. Simply attach it to the speaker side wall or listener side wall to reproduce realistic localization and a three-dimensional stage. By diffusing the air pools in the room, there is no interference and the sound can move freely around the room without stress, allowing the sound to exist accurately. Sound and music exist right in front of your eyes! That's the ultimate sound field reproduction! You'll be overwhelmed by the expressiveness of the sound, which is so realistic, deep and three-dimensional that it's as if instruments and singing voices are there.



General diffusion panel



[Sound image image of conventional diffusion panel]

Overwhelming improvement points

- color range
- focus
- sense of reality



SFW-HD



[SFW-HD sound image]

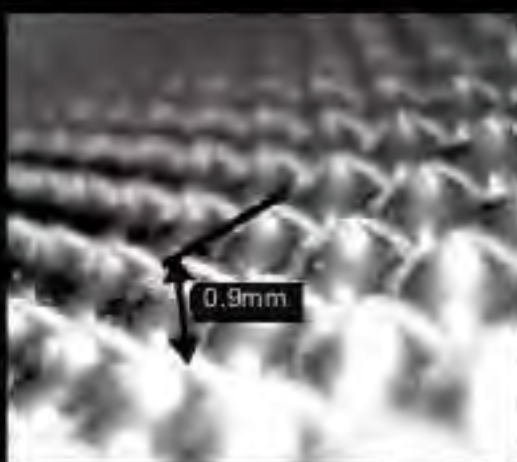

On the left is a 3D photo of the main structure of SFW-HD's special multilayer, the opposite of sound. There are countless special metal foils with calculated shapes that effectively diffuse overtones.

On the right is a photo of the main structure of SFW-HD's special multilayer, 2.4mm pitch,

Hole structure with a 0.9mm control shape that allows sound to pass through.



- Dimensions/approx. 1170mm x 400mm x thickness 11mm
 - Weight/approx. 1.95kg
 - Structure/Special material transparent embossed structure ■Material/
- approximately 80,000 pieces HD special structure harmonic diffusion material color
- Approximately 690 standing wave control holes

- Efficacy / Broadband energy low loss overtone diffusion
 - Summary / Required/Computer modeling and hearing check
 - Accessories/6 magic tapes
 - Standard /IV (Ivory) BR (Brown) BK (Black)
- price/¥132,000 (1 piece, tax included)



The SFW-HD has many standing wave control holes that react with the wall and can be used effectively even with a thin structure. I will use it.



"Harmonic Diffuser" Wall Panel" SFW-HD
(-IV Ivory, -BR Brown, -BK Black)



Audio Replus[®]
CO.,LTD.
REPRODUCE A PRIMARY SOUND



Won the Grand Prix of the Audio Accessory Masterpiece Award 2022



The cause was high frequency noise coming into the AC... A special power tap that delivers ultra-realistic high-end sound.

Since 2002, "Triangle Power6" has won the world's top class position as an ultra-high-end power strip due to its overwhelming performance housing design. In 2021, the newly designed casing that has rewritten that history is "Super Triangle Power6."

The housing is made of a special alloy that can attenuate broadband noise. The surface hardness is comparable to 450 Vickers carbide. We succeeded in reducing vibration loss due to one-phase shift in energy propagation throughout the entire range, and achieving overwhelmingly high-resolution sound.

The biggest topic is the adoption of a "dual noise absorber structure." By installing two layers of noise absorbers made of different types of special alloy powder, and further adding a noise 計3層を増やすことで pariah tunnel, we succeeded in significantly inducing all types of noise, from ultra-wideband noise to electromagnetic wave noise. Audio Replus has spent more than 20 years employing all kinds of technologies to create the perfect power distributor.



Measurement case (right, conventional product)

[High frequency noise induction test of the latest model SuperTriangle Power6]

The graph on the right shows the results of induction attenuation measurements of high-frequency noise from 800MHz to 1.5GHz, which muddies the sound the most. It has succeeded in attenuating high frequency noise by up to -15dB compared to conventional products. By graphing the overwhelming sound quality and S/N improvement, it proves how effective the noise attenuation effect is.



*Dual noise absorber structure. Inputs a 0dB high frequency reference noise signal from the inlet to the tap and from the outlet.

Measure the output noise signal. Measure how much noise is attenuated by passing it through a power tap.



Audio Replus Super high-end power tap comparison DATA

【Agilent Technologies 株式会社 Microwave Network Analyzers】

■Housing material/special alloy, special stainless steel

■Nail Shape / Monoblock machining using CNC machining center

■Structure Built/outlet power plate structure (30mm),

Inlet cover structure (25mm),

Separate structure, separate wiring

■Noise removal method/special dissimilar alloy powder layer x 2 layers, triple noise barrier tunnel structure, ■heavy

Separate structure, all ruthenium contacts

■Inlet / Ruthenium plated highest grade inlet

■Outlet /RWC-2RU x 3 (6 ports)

■Internal wiring/ruthenium plating high purity copper single wire, high purity PTFE coating

■Physical property treatment/Signature Nano Cryo Ultra

SZ ■Accessories/Special stainless steel spike receiver, insulator, gloves

■Each part plug insertion diameter/up to 42mm

■Size Size/250mm×250mm×95mm

—10.0kg (accepting spikes)

■Standard price/¥1,210,000 (tax included)

*Super Triangle Power 6 STP-6 100 units limited model



Power strip product page



Filled with dignity, breathing soul

A new milestone in music playback



Kagura2

211 Monaural Power Amplifier

Rated output: 50W Weight: 62kg Dimensions: 320W x 370H x 568D

Audio Note Co., Ltd.

242 Shimohirama, Saiwai-ku, Kawasaki, Kanagawa 212-0053

TEL: 044-520-3150 FAX: 044-555-8350

www.audionote.co.jp

Domestic authorized dealer

S.I.S. Co., Ltd.
Art Crew Co., Ltd.
sound pit

5-42-5 Sendagi, Bunkyo-ku, Tokyo 113-0022
7-1-9 Nishijin, Sawara-ku, Fukuoka 814-0002
2-13 Kamisha, Meito-ku, Nagoya 465-0025

TEL: 03-3824-1139
TEL: 092-842-2555
TEL: 052-775-7901

www.sisaudio.co.jp
www.artcrew.co.jp
www.sound-pit.jp

10th year excitement
APEX Ring DAC



Vivardi APEX DAC

¥5,290,000(tax not included) ¥5,819,000(tax included)



Rossini APEX DAC

¥4,070,000(tax not included) ¥4,477,000(tax included)



Rossini APEX Player

¥4,460,000(tax not included) ¥4,906,000(tax included)

[APEX Upgrade Service]

Target devices: Rossini DAC, Rossini Player, Vivardi DAC, Vivardi One

¥1,280,000(tax not included) ¥1,408,000(tax included)

SME

Since 1946

PRECISION TURNTABLE

60

MADE IN ENGLAND



Coming-soon!!

Riziere

Riziere Co.,Ltd.

〒110-0005

Kotokudo Building 403, 5-7-7 Ueno, Taito-ku, Tokyo TEL: 03-6240-1965 FAX: 03-6240-1581 <http://www.riziere.biz/>

IASJ
International Audio Society of JAPAN

A



FYNE

VINTAGE



BACK IN THE DAY
NEVER SOUNDED SO GOOD

A fusion of modern engineering and technology. Fine Audio Vintage Twelve & Classic X.



Stereo Sound

C O N T E N T S

71 Decision!

Stereo Sound Grand Prix STEREO SOUND GRAND PRIX 2022

Hiroji Onodera/Shinpei Fu/Takashi Miura/Koriki Yanagisawa/Tadashi Yamanouchi/Hiromi Wakawa

Shun Harada (Chief Editor of this magazine) Hajime Someya (Editor-in-Chief of this magazine)

144

CRITICS' APPLAUSE

169 Special feature By genre/price range '22 '23

527 Best Buy Components

Hiroji Onodera Nobuyuki Kenji Mayuzumi / Takahito Ichihara / Tadashi Yamanouchi

182 About mountain selection method

184 •Speaker system---134 models

199•Digital disc player 36 models

204 •Digital disc transport 11 models

206 D/A converter-24 models

209•Digital file player-19 models

210•Preamplifier---47 models

215•Power amplifier---66 models

221 •Integrated amplifier 41 models

226 •Analog player 25 models

228•Phono cartridge 36 models

230 •Phono equalizer amplifier---30 models

233•Other components - 32 models

234 •Sound accessories 26 models

265 Serial: Pleasure of listening to record art

Tetsuya Okazaki

276 serialization

listening mirror

Shoichi Sugawara

278

“Ei Otaki Omnibus 50th Anniversary Edition]”

The charm of Eiichi Otaki

Shinichiro Kobayashi

282

Record of visit to Valtele

Koji Yamamoto

290

Abbey Road Studios

Interview with Miles Showell

Listener Editorial Department

313 Series Create and talk

Luxman Mr. Tetsuya

Sueyoshi / Mr. Masaru Nagatsuma

Mr. Yasuto Omori / Mr. Keita Kitazawa (SAEC) — Listener/Composition Hiroshi Onodera

Kojo Technology Mr. Nayoshi Toki / Composed by Hiroji Ono

324

Interview with Gillard Tiefenbrunn and Steve Croft about the concept of Lin

Chuzan's new product "Selekt DSM: Edition Hub" Composition: Takayoshi Ito/Interviewer: Editorial Department

328

2022 Tokyo International Audio Show Report Listener Kenji

Hiroshi Miyashita

333

SS Interview

Mayuzumi / Takahito Miura / Hiroshi [r]

Yamamoto Avant-garde = Mr. Jerome Andre / Mr. Dali = Lars Warne

Lumin-Nelson Chey, Lee Ong, Angus Leung

Pirium-Konstantinos Piliou SME-Stuart McNeills

2023

quarterly stereo sound

winter issue

No.225

338 serialization

audio ontology

Masaya Shimoshiba

344 serialization

Continued: The Pleasure of Nearfield Listening

Hiroyama Wada

348

Series: Biography of Japanese Engineers: Mr. Shozo Inomata

Composed by Ryugo Ito Kaide Editorial Department

361

Thorough preview of new winter models

Exciting Components

•Wilson Audio = Alexx V-- Tadashi Yamanouchi •Dali = Kore Ura Takahito

•Marten = Mingus Quintet. 2 Statement. Edition-----Hiroji Onodera

•B&W = 70253. 70353 705S3-----Nobuyuki Fu • Mark Levinson = ML50-----Hiroji Onodera

•Burmester = 216 Hiroshi Onodera •Accuphase = A300 Takahito Miura

•Luxman = PD191A Takahito ----- Ichiura

•DS Audio = DS-W3 Cartridge. DS-W3 Equalizer Hiromi Wada

•Fidelix = MC-F1000---Takahito Miura •Pyrium = Alexander/Hercules-Tadashi Yamanouchi

385

New Components Review 2023 WINTER

Listen to the hottest new products

Hiroshi Onodera/Ken Funobu/Takahito Miura

Masa Yamanouchi Hiroshi Yamamoto Hiromi Wajama

421

SOUND SCOPE

Takahito Miura

422

Listening disc list

423

SS HOT NEWS

Takahito Miura

433 serialization

SS NEW MUSIC GUIDE & ESSAY for Audiophiles

Classic = Hiroshi Miyashita, Hiroshi Tojo Popular = Shinichiro Kobayashi/Hiromi Wada

442 serialization

Masterpiece Deep Listen

Kentaro Takahashi

446 serialization

Famous songs are ingrained
Reason

Shinichiro Kobayashi

448 Series Famous mountains have their reasons.

Atsuya Funaki

452

berlin phil recordings

Reprint of wartime Furtwängler selections on analog LP record.

Hiroshi Miyashita

453

Esoteric SACD masterpiece reprint series, 4 works released

Hiroshi Miyashita

454

Berlin Classics x Tower Records SACD reprint series released one after another Hiroshi Miyashita

455

New Steeple Chase SACD Hybrid Selection

Yamato Ohara

456

Takahito Ura's two works from the "East Wind" label are revived as analog LP records.

457

The winning works of the 28th Japan Professional Music Recording Award have been decided.

458

SS Information

460 series

musical abduction

Huh Mitsujun

462

Notice of start of orders for Uesugi U Bros 330AH "Limited Edition"

New Components Review 2023 WINTER

speaker system

394 Audel	U-Basik 5/8
386 Avant Garde	Trio G3+SpaceHorn Twin Drive +SpaceHorn Single Drive
388 Fine Audio	Vintage Twelve
411 Krypton	KX3SX
390 Piega	Coax 611 / Coax 411
410 Spendor	A4
392 TAD	TAD-CE1TX

SACD/CD player

413 Denon	DCD1700NE
396 Technics	SL-G700M2

CD PLAYER

412 Nmode	X-CD5
-----------	--------------

digital file player

415 Electrocompanier	ECM 1 Mk II
----------------------	--------------------

digital file transport

414 Lumin	U1X
-----------	------------

Power Amplifier

400 Esoteric	S05
398 Usugi	U · Bros 330AHWE

Integrated amplifier

404 Accuphase	E4000
402 Macintosh	MA9500

phono cartridge

417 Ortofon	MC Diamond
416 Phasemation	PP5000

phono equalizer

406 Divas	Model 1
418 Krell	K300p
419 Meitner Audio	DS-EQ2

music server

408 DELA	N1-S38-J
----------	----------

Switching hub

408 DELA	S100/2-C-J
----------	-------------------

Zerolink dedicated USB bridge

420 soul note	B3
---------------	----

art director

Kenji Tsukako

cover photo

Alon Wolf

wooden pattern design

Kensuke Tsukamoto

Masako Yamanishi

body is true

Kumi Utsuyama

Riichi Aizawa

Atsuko Goto

Akito Shimazu

stereo sound editorial department

cover

Alon Wolf
with
the MAGICO M9



Stereo Sound

GRAND
PRIX
2022

stereo sound
Grand Prix

Genre

LOUDSPEAKER

LOUDSPEAKER

LOUDSPEAKER

LOUDSPEAKER

LOUDSPEAKER

LOUDSPEAKER

LOUDSPEAKER

LOUDSPEAKER

LOUDSPEAKER

LOUDSPEAKER

LOUDSPEAKER

LOUDSPEAKER

LOUDSPEAKER

SACD/CD PLAYER

D/A CONVERTER

MUSIC SERVER

MUSIC SERVER

POWER AMPLIFIER

POWER AMPLIFIER

POWER AMPLIFIER

POWER AMPLIFIER

POWER AMPLIFIER

POWER AMPLIFIER

POWER AMPLIFIER

POWER AMPLIFIER

AD PLAYER

AD PLAYER

AD PLAYER

PHONO CARTRIDGE

PHONO CARTRIDGE

PHONO CARTRIDGE

Hiroji Onodera

Koji Onodera

Nobuyuki

Fu

Takahito

Miura

Isao

Yanagisawa

Tadashi Yamanouchi

Tadashi Yamanouchi

Hiromi Wada

Hiromi Wada

Kun Harada (chief editor of this magazine)

Isao Iarada

Someya → (Editor-in-chief of this magazine)

Hajime Someya



Award

Made



brand

model name

price

01		Maju	M9	¥135,000,000 (pair)
02	wilson audio		Alexx V	¥29,000,000 (pair)
03	Avalon		Isis Signature	¥ 16,700,000 (pair)
04	dali		Kore	¥15,000,000 (pair)
05	Arale		Remiga2	¥11,800,000 (pair)
06	Marten		Mingus Quintet 2 Statement Edition	¥10,000,000 (pair)
07	Esteron		XB Diamond MkII	¥5,800,000 (pair)
08	fine audio		Vintage Twelve	¥4,700,000 (pair)
09	german physics		HRS130	¥4,200,000 (pair)
10	T.A.D.		TAD-CE1TX	¥2,700,000 (pair)
11	Piega		Coax 611	¥2,840,000 (pair)
12	Ehlab		Concentro S 503	¥1,200,000 (pair)
13	B&W		702S3	¥1,036,000 (pair)
14	Luxman		D07X	¥750,000
15	dCS		Vivaldi APEX DAC	¥5,290,000
16	tyco audio		SGM Extreme	¥5,260,000
17	DELA		N1-S38-J	¥1,200,000
18	Dan D'Agostino		Momentum M400MxV	¥13,900,000 (pair)
19	pyrium		Hercules	¥12,500,000 (pair)
20	mark levinson		ML50	¥5,500,000 (pair)
21	macintosh		MC3500	¥4,400,000(pair)
22	Burmester		216	¥4,350,000
23	soul note		M3	¥3,000,000 (pair)
24	accuphase		A300	¥2,700,000 (pair)
25	Japanese cedar		U·Bros 330AHWE	¥2,100,000 (pair)
26	esoteric		Grandioso T1	¥7,000,000
27	Valtele		SG1 PKG	¥4,800,000
28	Luxman		PD191A	¥900,000
29	Phasemation		PP5000	¥1,350,000
30	ortofon		MC Diamond	¥1,180,000
31	DS Audio		DS-W3 Cartridge	¥450,000

Stereo Sound

GRAND PRIX 2022

Confirmed! Stereo Sound Grand Prix

Based on that nomination list, the selection committee held a series of rounds of voting until consensus was reached, and the StenO-Sound Grand Prix was selected as the consensus of the selection committee.

As I always say, the most important

The main feature of Dai is that it ignores price considerations.

Therefore, no matter how expensive the product is, even if it is extremely cheap, we will consider it for selection. Furthermore, because the awards are not selected by genre and there is no fixed number of award-winning products, the results reflect trends in the audio world that year.

Ikuji Miura: The balance of the number of award-winning products in each genre fluctuates. There is no selection by department at all. There are other rental companies that deal with audio equipment, but this is probably the biggest difference between them and other rental companies.

Yanagisawa: The annual-award for "Sten-O-Sound" started with the 1978 work, and this year marks the 45th time, but the basic stance of making selections without considering the boundaries of price and genre has remained consistent.

Editorial Department: So to speak, it's an indiscriminate class. In addition to sound quality, we also consider the quality of our products from a comprehensive perspective, including design, finish, usability, technology, innovation, reliability, continuity of tradition, and innovation.

Editorial Department Outstanding audio equipment of 2022

The selection of "Stereo Sound Grand Prix" presented to it ended successfully. This year, three products were selected for the Grand Prix, and among them, the Magico M9 won the Golden Sound Award. The selection process

included 6 votes from 6 audio critics, including members from last year, including Onodera Butsushi, Fu Nobuyuki, Ura Takahito, Yanagisawa Kōriki, and Wakawa Hiroshin. Editorial Department members Hajime Harada and Hajime Sometani were asked to vote on a total of 7 years old on a 1 m² area. The targets were all audio equipment released this year. From among them, each selection committee member selected in advance the upper limit. Nominated model in 30 models



Committee members are asked to evaluate audio equipment.

Now, I would like to talk about the overall selection process for this work. Furthermore, regarding the year and work of each award-winning model, we avoided a round-table discussion and asked three people for each model to write the manuscript, but this year, we would like to hear from everyone about the Golden Sound rental products. I would like to receive it.

Now, Professor Ichimura, please give us your overall review.

**Awesome audio,
splendor
make you realize
A dream super-dread product
Arranged in a row
spectacular grand prix**



Eight members of this year's Stereo Sound Grand Prix selection committee. 5 On the far left is the newly appointed Tadashi Yamanouchi, followed in order by Hiromi Wada, Hiroji Onodera, Kouriki Yanagisawa, Takahito Miura, Nobuyuki Fu, Kun Harada (Jukan Editorial Director of Mokushi), and Hajime Someya (Editor-in-Chief Mokushi). Furthermore, Harada and Someya are the two representatives of the editorial department and have one vote. November 1, 2022 at Stereo Sound Company.

speakers and power amplifiers

It is noteworthy that it is fulfilling.

On the other hand, there has been a major change in the award balance for source equipment.

Miura: Not only in the audio world, but the infectious disease control measures that began in 2020 have created various difficulties and restrictions around the world, and there are many cases where product development and release are hindered or delayed.

Hajime Onodera: Last year's products were still in stock from the previous year, so I didn't get the impression that it had a big impact, but last year and this year, the number of new products was lower than usual.

Yanagisawa: It's a problem of social and global circumstances. Therefore, it can be said that there is no other choice. And while it's true that the number of products may have decreased, it's just a matter of numbers, and even under these circumstances, I think the content was quite substantial.

Miura: That's right. There were many products that gave us memorable and wonderful sounds. Onodera:

It is amazing that such excellent audio equipment is being delivered from all over the world in these difficult times. It's also amazing.

Miura: Well, I mentioned earlier that the balance between genres changes from year to year, but looking back at this year's list of award-winning products, I was surprised to find that there was one award-winning model each for a digital denonk player and a D/A converter. On the other hand, there are three analog players and a phono cartridge.

With three models now available, analog devices now dominate in terms of numbers.

Onodera: It's very moving to remember that there was a time when analog equipment was considered to be a dead giveaway.

Miura: However, there are a lot of things worth mentioning when it comes to digital devices.

The model, which is also called a network attached storage (NAS) or music server, which stores sound sources, was also selected for the Grand Prix. Fu: This has never happened before.

Miura: That's right. network audio, in other words, it was a surprising and happy event for Hakubun, who is promoting the creation of digital files in-house.

Continuing the topic of genres a little further, this year's unique feature was that there were no winning entries for preamplifiers or integrated amplifiers, while there were many award-winning entries for speaker systems and power amplifiers. I wasn't aware of it at all when I was voting, but it was quite special.

I think it would have been a different work. As Mr. Onodera Imaura said, I think the biggest feature of this year is that the balance of genres of the award-winning products was strikingly different from previous works. I felt that we were now standing at a turning point in history in many ways. In terms of audio, this has been happening for a long time, but it is deeply related to the major changes in the way music sources exist.

The style of listening to music is, from a global perspective, from digital disks to digital files and

It is undeniable that streaming via the Internet is becoming more and more popular, and one of the things that audio needs to do is how to enjoy digital files with great sound, and the results of this hardware will be announced this year. It seems that this has become a characteristic of the company. Of course, in recent years, excellent network players and digital file players have been introduced and have won grand prizes, but music servers have When I came in, it got even more lively.

Furthermore, the presence of analog code as a packaged media is increasing, and I believe that this is reflected in this year's award-winning works. I was also very impressed by the large number of power amplifiers they produced.

However, I would like to say one thing: Although I am fully aware that there are price increases for various products and exchange rate issues, I still feel that the amount of expensive audio equipment has increased. I think we need to stop and think about this. It's true that there are no price restrictions at the Grand Prix, and it's a place to talk about your audio dreams, and I admit that some expensive products have achieved great results, but I don't think things can stay as they are. do not have. A direction towards achieving excellent sound quality at a reasonable price I believe that we must actively support

About the Stereo Sound Grand

Prix selection --- Editorial Department

Selection criteria

① Sound quality ② Design ③ Finish ④ Operation
feel ⑤ Originality ⑥ Reliability ⑦ Advancedness

Selection for the Stereo Sound Grand Prix is based on the seven criteria listed above, with emphasis placed on audio products that are excellent overall. Sound quality is not the only criterion for Grand Prix selection. In addition, as a general rule, selection is made without regard to price or genre, and there is no limit to the number of award-winning products, so the balance between genres and the number of award-winning products change from year to year.

Products

All new audio products released in Japan in the past year. However, (1) the sound quality and functionality must be complete as of October 30th, and previews must be available. (2) It will be distributed in the domestic market within this year. Two conditions must be met. This year's new products that do not meet the conditions will be eligible for next year's Grand Prix. Therefore, the models introduced as new products in this issue include products eligible for next year's Grand Prix.

nomination

Audio products released this year are available from each manufacturer and import agent.

When the editorial department receives information from a store, it will be automatically posted on the list, and all products will be eligible for the Grand Prix. After confirming with each company the availability of previews and release dates by the trial deadline of October 30th, a list of eligible products will be created (approximately 180 models were listed this year). Based on this list, each selection committee member will nominate up to 30 models based on the audition results. The deadline for nominations is October 31st. In addition, Harada and Sometani are representatives of the editorial department of this magazine and have one vote.

Selection method

The selection date is November 1st. Voting will be based on a point system based on the list of products nominated by each selection committee member (63 models were nominated this year). A list of nominated products is shown on pages 78-79. Based on this list, the products are narrowed down through repeated voting, and once all the selection committee members agree, the Grand Prix winning product will be decided. Please note that there is no limit to the number of Grand Prix winning products. Among the Grand Prix winning products, the Golden Sound Award is given to the most outstanding product.

I am. In

What Mr. Miura and Mr. Onodera just covered the characteristics of this year. Yanagisawa: want to say out loud is S.I think I've pretty much complete than ever before. I'm here, but what I speaker systems have become more and more behind the times, but over the past few years, have improved rapidly. I've said that we're particularly evident. S Performance and sound quality face of audio after all. I think this was audio more enjoyable, and the speaker is the learning good. What I mean by this work is that it makes conclusion, the grand prize of this work is very I think that was the result.

music has changed. As Fu Ono said earlier, 在

2016. I personally feel that the way I listen to music, I think it was the Grand Prix that I felt in and SACDs, and to be honest, in pursuit of new To begin with, I've bought about 300 CDs their debuts, but this year I only bought 15 discs. mainstream, discs are the way musicians make Now that distribution over the Internet has become digital files, so there are very few new releases. have been putting a lot of effort into creating We are facing a big milestone. Since then, I However, as you can see from the analog code. A huge number of digital discs have been distributed so far. Therefore, the importance of playback equipment is

not changed at all, but have become even more important.

the Critics Applause. In that sense, digital disc players have Grand Prix, but there is one model in the Grand Prix, I thought it was a shame that there were two models in the is. The number models not only on the axis but also in a wide range of areas. is increasing. As you said, it is true that there are many excellent of models that can enjoy good sound in a wide range of speakers I also feel that technology is evolving. products are truly passionate about audio. who have created so many amazing The "audio guys" around the world Wada: I live in the mountains, preferably with a compact truck.

Stereo Sound GRAND PRIX 2022

Nominated products

Genre	brand		price
LOUDSPEAKER	1 quadral	Signum 90	¥250,000(pair)
	2 krypton	KX3SX	¥398,000(pair)
	3 B&W	705S3 (Gloss Black)	¥512,000(pair)
	4 B&W	702S3 (Gloss Black)	¥1,036,000 (pair)
	5 Elak	Concentro S 503	¥1,200,000 (pair)
	6 Viega	Coax 411 (Silver)	¥1,400,000 (pair)
	7 Dynaudio	Contour 60i	¥1,650,000 (pair)
	8 Plega	Coax 611 (Silver)	¥2,650,000 (pair)
	9 TAD	TAD-CE1TX	¥2,700,000 (pair)
	10 German Physics	HRS130 (High Polish Black)	¥4,200,000 (pair)
	11 Fine Audio	Vintage Twelve	¥4,700,000 (pair)
	12 Esteron	XB Diamond Mkl	¥5,800,000 (pair)
	13 マーテン	Mingus Quintet 2 Statement Edition	¥10,000,000 (pair)
	14 Arale	Remiga2	¥11,800,000 (pair)
	15 dali	Kore	¥15,000,000 (pair)
	16 Avalon	Isis Signature	¥16,700,000 (pair)
	17 Wilson Audio	Alexx V	¥29,000,000 (pair)
	18 Avantgarde Trio	G3+SpaceHorn Twin-Drivex2	¥49,100,000 (set)
19 Magico	M9	¥135,000,000 (pair)	
SACD/CD PLAYER	20 Technics	SL-G700M2	¥370,000 (tax included)
	21 Luxman	D07X	¥750,000
	22 CH Precision	D1.5	¥5,550,000
D/A CONVERTER	23 dCS	Vivaldi APEX DAC	¥5,290,000
DIGITAL FILE TRANSPORT	24 Lumin	U1X (Silver)	¥1,210,000
PREAMPLIFIER	25 Phasemation	CM2200	¥1,800,000
	26 Macintosh	C12000	¥2,300,000
	27 Goldmund	Mimesis 37S Nextgen	¥3,200,000
	28 Pyrum	Alexander	¥7,000,000
POWER AMPLIFIER	29 Esoteric	S05 (Silver)	¥900,000
	30 Accuphase	P7500	¥1,350,000
	31 Usugi	U-Bros 330AHWE	¥2,100,000 (pair)
	32 Accuphase	A300	¥2,700,000 (pair)
	33 Soul Note	M3	¥3,000,000(pair)
	34 Burmester	216	¥4,350,000
	35 Macintosh	MC3500	¥4,400,000(pair)
	36 Esoteric	Grandioso M1X	¥5,200,000 (pair)

statements like it's preferable to use audio equipment: dreams, but the "Stereo Sound Grand Prix" is making particular, it's going to be a stage for super-dreaded audio that I don't think it's worth it, and this year in there are a lot of products from the makers. It's true I don't want to buy something that's too expensive, but

Filled with passion, without considering cost. want, and it's really impressive to see them lined up, but it was, and it was spectacular. "Audio guys" from all over the world who truly love audio can do whatever they I'm most happy that they've created something amazing. Ta.

audio deals with the art of music. change that. When I think about it, audio concert hall, and in some cases it can makes you feel like you're at a You can get a musical impression that That's an amazing thing.

Genre	brand		price
POWER AMPLIFIER	37 Mark Levinson	ML50	¥5,500,000 (pair)
	38 Epsilon	Aelius 2 Mono SE	¥7,800,000(pair)
	39 Pyrium	Hercules	¥12,500,000 (pair)
	40 Dan D'Agostino	Momentum M400MxV	¥13,900,000 (pair)
INTEGRATED AMPLIFIER	41 Marantz	Model 40n	¥260,000
	42 triode	Evolution	¥500,000
	43 Accuphase	E4000	¥630,000
	44 Macintosh	MA9500	¥1,740,000
AD PLAYER	45 Luxman	PD191A	¥900,000
	46 Lin	Selekt LP12	¥1,775,000
	47 Valtele	SG1 PKG	¥4,800,000
	48 Esoteric	Grandioso T1	¥7,000,000
PHONO CARTRIDGE	49 Audio Technica	AT-ART20	¥300,000
	50 Fidelix	MC-F1000	¥400,000
	51 DS Audio	DS-W3 Cartridge	¥450,000
	52 Ikeda	Akiko	¥777,000
	53 Lin	Ekstatik	¥950,000
	54 Ortofon	MC Diamond	¥1,180,000
PHONO EQUALIZER	55 Phasemation	PP5000	¥1,350,000
	56 DS Audio	DS-W3 Equalizer	¥850,000
	57 EMT	EMT128	¥1,400,000
	58 HSE Switzerland	Referenceline 7	¥4,300,000
MUSIC SERVER	59 Epsilon	VPS100 SE	¥5,800,000
	60 DELA	N1-S38-J	¥1,200,000
MC TRANS	61 Tyco Audio	SGM Extreme	¥5,260,000
RECORD STABILIZER	62 Epsilon	MC-L SE	¥2,300,000
	63 DS Audio	ES001	¥550,000

That's right. Couldn't be more beautiful. I'm sure it's a great hobby. Onodera: Wada: The wonders and greatness of such audio products in this year's Grand Prix that will make you feel it was there. That was really nice. There are many

Yamanouchi: This is the first time for me to use the "Stereo Sound Lamp"

grateful for the opportunity to participate in the selection process for with the significant amount of time and results. I am very thank you. I am very impressed

From a general perspective, the story has already been said.

As mentioned above, over the past three years, there have been major changes in society and work styles, and we are working hard to address the current issues that have arisen

to create and develop this year's products. usual. In many cases, it took a lot of time result of pushing the sound even further than When I listen to the product, I feel like the I think I heard it.

commemorating the 50th anniversary of the company's founding.

would like to mention is a commemorative work use of new power. So-called anniversaries. Another thing I change from those who were able to make good model, which suggests that they are undergoing a generational audio brands have recently launched a founder has released an excellent product. This suggests that many In that sense, I think it was a turning point, and Rand is.

is impressive, but this is still the case. significantly, and the reproducibility used to produce the sound has evolved improved. The power amplifier system

Perhaps the performance has precise, delicate, and transparent low-level power amps. and there were many monster amps with beautiful over the world. They were all products with sound, It was a year in which changes could be felt all

Mura: On the other hand, the preamplifier is excellent from the beginning.

just amplifiers. It has been said that it is difficult to reduce the signal level, but today's preamplifiers are not function, it is necessary to emit good sound and paucity of products available. Since this is the most popular The difficulty of achieving this is reflected in the

Maybe it will.

Onodera: Also, in the case of preamplifiers, the current position of preamplifiers is difficult because of how they will respond to digital sources. Considering convenience and majority, digital input and

It's definitely better to support network connectivity, but I think each manufacturer is struggling to find the best solution when putting sound quality first. For us, regardless of your preference, we would like to offer a player that has good sound and is comfortable to use.

I'm just looking forward to the arrival of the reamp.
Editorial Department Thank you. Next, I would like to ask you about the Golden Sound Award.



A truly golden sound. Even orchestras and big bands. Makes me think it's real size

Editorial Department "Sten O Sound Grand The "Golden Sound Award" is given to particularly outstanding performance among the award-winning products, and Magico's M9 speaker system was selected for the 2022 award. Yanagisawa: "As soon as I listened to this speaker, I was convinced that it was the only one that would win the Golden Sound Award! I thought the sound was on a completely different level compared to previous speakers, not just this year's. That's amazing

It's a system. Miura: I felt exactly the same way. Of course, there were other great new products, but I was convinced that nothing was more deserving of the Golden Sound Award than the sound produced by the Magico M9. Yanagisawa: The ideal speaker system is I think the idea is to let you hear only the air compression waves generated by the vibration of the knitwear, but what about the previous ones?

M9 made me realize that there was a sound from the enclosure and the cry of the white unit. I realized how amazing it is that there is no unnecessary noise. Moreover, it has achieved this over a wider range than ever before. For that purpose, it must have been that size, that weight, and that cost. Anyway, I thought that was the golden sound of the point.

Miura: For example, when increasing or decreasing the number of points,



LOUDSPEAKER

Magico M9 ¥135,000,000 (pair)



•Model: 4-way 6-speaker, sealed type •Units used: Woofer: 38cm cone type x 2, Midbass: 28cm cone type x 2, Midrange: 15.2cm cone type, Tweeter: 2.8cm dome type •Crossover frequency: 120Hz, others not disclosed •Sensitivity: 94dB/2.83V/m Impedance: 40 •Dimensions Weight: Speaker: W510×H2,030×D1,020mm/454kg, MXO crossover body: W510×H200×D460mm / 18kg, MXO cross Over power supply / W510 x H200 x D460mm 27kg Notes: 2-way electronic crossover (MXO) is included, 2 stereo amplifiers or 4 monaural amplifiers are required for playback of this unit. Contact: Electric Co., Ltd. ☎03 (5419) 1594

★Preview publication, No. 223

This was the first time I had experienced the feeling that only the location had changed. The form of music does not change at all. There was no swelling or thinning at all.

Fu: It's a victory for Linear Liteno. -

If you put in 1, if you put in 1000

I put 1000, 0.00000.....

50.00000... is output as sound.

It will be done. So even though it's about the same size as a dog, the speakers disappear when the sound comes out. I thought it was an overwhelming accomplishment.

Wada: I think it's a precise, precise, transparent, and faithful speaker, but there's more to it than just that. When I turn up the volume An unexpected world appears.

Miura: Even in an orchestra or a big band, it gives off a scale that makes you think it's real size.

Wada: The speaker unit grips all of my energy, and the vibrations of the music that it generates come towards me and envelop me, and I feel a bit of a shiver, or rather, a kind of fear that sends shivers down my spine. Ta. Experiences like this are not common. I was so nervous. A speaker like this is an audio dream.

I thought it was really amazing that

Car appeared.

Yamanouchi: I completely understand that it's scary. But doesn't it feel good?

Wada: It felt good (lol).

Yamanouchi: With the M9, I was able to experience a scary yet pleasant sound that I had never heard with other speakers. For example, the ultra-low-frequency linearity and low distortion are unprecedented, and it gives the impression that the entire floor of a concert hall stage is resonating. It starts to sound boring.

Onodera: The lack of incidental sounds also contributes to the high resolution in the ultra-low range, but bi-amplification drives the woofer. The fact that we were able to eliminate the passive network of the router must also be very significant. Miura: The energy and information loss caused by band division using passive networks cannot be ignored in the low frequency range. Developed an active crossover. It has also brought success to I will.

Yamanouchi: That's certainly true. And, in an actual concert, this kind of ultra-low range is received by the whole body, and it is heard as a sound. I think it's rare to realize this, but

The realism and realism of being at the music scene Listening to the M9, I realized that the element of quality actually depends on the reproducibility of this area. There were many times when I realized that this recording contained such sounds. I wrote a little about the Onodera M9 in the previous issue of this magazine. In return, this is a system that realizes the technical ideals of high-end audio to an unprecedented level, namely speakers with ultra-wide range, ultra-flat response, ultra-high resolution, and ultra-high linearity. So deserving of the Luden Sound Award



MXO M9 dedicated 2-way stereo active crossover (included)

There is some disagreement that there is no such thing not. However, I am not satisfied with this price. There is definitely some resistance, in this place This may not be an appropriate comment, but I would like to state that. That being said, I think that the large number of sounds, lack of turbidity, and wide range are unique, and at the same time, the efforts of the person in charge at the importer who brought out these capabilities to their fullest must be credited.

He generously praised his strength and love. I think so. I'm sure you all understand how difficult it is to actually get good sound from that many speakers, and we're hearing the results of more than half a production's worth of adjustments. Miura: That's certainly not the case in a audition setting. You have to replace the listening device, and the general

If you are listening to audio equipment, this is the case. I don't think there's anything I can do. Onodera: That's right. In any case, I think it can be said that the Golden Sound Award was a result of the passion of both the creator and the performer. I feel like I've seen the true essence of audio. I don't think anything like this has ever happened before.

MAGICCO



WILLSOM AUDIO



LOUDSPEAKER
wilson audio

Alexx V ¥29,000,000(pair)

●Model: 4-way 5-speaker bass reflex type ●Units used: Woofer 32cm cone type + 27cm cone type, Midbass 18cm cone type, Mid-high 15cm cone type, Tweeter 2.5cm dome type ●Sensitivity: 92dB/W/m ●Impedance: 40 ●Dimensions, weight: W400 x H1,610 x D680mm/227kg Note: The price shown in the photo is standard color quartz, Galaxy Gray, GT Silver, Carbon, upgrade color available at an additional price (¥ 30,000,000/pair) Various types available, Saran net available in various colors ●Inquiries: Stella 03 (3958) 9333

*Preview publication 10/2022

02

A model that has released its past and has become even more attractive.

Developing a world of organic and majestic sound

Wilson Audio's achievements in setting the trend for modern high-end speakers are beyond doubt, and they have produced models that serve as a model. The company was founded by broadcaster David Wilson, and his son, Darryl Wilson, has carried on the lineage and designed products that pay homage to the founder. I felt that recent products were, so to speak, a collaboration between the two.

However, this work is different.

Featuring a fresh, responsive sound, this sound allows designers to do what they want without being stuck in the past.

I can't help but think that this was the result of a show of skill. There's a boldness to it that makes you feel like you've just hit the nail on the head, and it feels good to listen to it. Of course, the performance is one of the best in modern times. A highly detailed, organic world unfolds on a grand scale and with high resolution. Onodera

Today's Wilson Audio has made a historic leap through the active leadership of product development by

Darryl Wilson, son of designer and founder David A. Wilson (died in 2018).

There is. This machine is a clock similar to the top WAMM.

Quality achieved by Ronosonic VXX/

The next generation model of Alexx, with no spared knowledge. In addition to a mechanical

mechanism that allows fine adjustment of the driver position for the listener, a new midrange equipped

with four alnico magnets, similar to the higher-end models, provides a well-focused sound image

and magnificent musical expression. It's great that you can do both. The bass reflex port, which allows

you to choose between the front or the back, is also unique. Carbon fiber on the back of the tweeter

The Convergent Synergy Carbon, which is equipped with a carbon fiber chamber, is also a new

Innovation from this machine.

Miura

The company has a long history, dating back to 1974, but this is probably a registered product, and its name as a speaker had been well-known among American enthusiasts for several years before that. The most representative machine was a small monitor machine created by founder David Wilson, who loved recording, but the number of products has continued to increase, and today there are many people who like wooden machines, mold Machines are also lined up.

However, this series of humanoid aircraft is

In Japan, his reputation was always at the level of "just one more step." However, in the era of Darryl

Wilson, who took over from his late father, the appeal of the company's machines greatly

improved. This series was also known for its unique style, but the current model has a spacious sound,

sensual tone, and rich expression that are suitable for that, making it possible to hear the sound that

you would expect from a high-grade machine. It's set.

Yamaguchi



AVALON

LOUDSPEAKER

Avalon

Isis Signature ¥16,700,000 (pair)

•Model: 3-way 4-speaker bass reflex type •Units used: Woofer 33cm cone type x 2, midrange 18cm dome type, tweeter 2.5cm reverse dome type •Sensitivity: 90dB/2.8 3V/m •Impedance: 40 •Dimensions/Weight: W370×H1,520×D430mm/80kg
Note: The finish and price shown in the photo is standard wood (birdseye maple), and the additional price (¥17,400,000/pair) is premium wood (curly maple), cherry, walnut) available
•Inquiries: Taiyo Co., Ltd. International 03 (6225) 2777 *Preview publication No. 221

03

Achieve even higher levels of expressiveness.

Warm, open and lively sound

Previous Avalon designs were highly rigid

It was the intention. However, in recent years, rather than using rigidity to suppress vibrations, methods have been developed to inactivate vibrations, or to explain it in my own way, designs that quickly dissipate vibrations, have achieved not only high performance but also truly musical expressiveness. It's here. This is a clear departure from the simple hi-fi philosophy that only requires high linearity, and would be impossible without a thorough understanding of how music sounds.

The original Isis model is also attractive.

However, the Signature model incorporates the new methods mentioned above and is equipped with a new woofer, resulting in even more responsive expression, a crisp yet warm texture, and a bold behavior. As the company's best work and currently the most wonderful speaker system.

Listed as the most right wing.

Ondera

Avalon has accumulated valuable speaker

design know-how through the development of the super-class machine, the Isseract. Taking advantage of this, the company's core model, the Precision Monitor series, was developed, and Isis evolved into Signature Saka. When drivers are supplied by specialized manufacturers like the company, development and manufacturing are concentrated on the enclosure and network. The enclosure is made of a new material instead of wood to effectively reduce vibrations. The components used in the network, even the cables, have been carefully considered to ensure that they can handle large currents and do not cause phase shifts.

This is the structure. The

background of the music is very quiet, and the sound is extremely smooth and rich. Every time the music starts, a sound image emerges as if it is erupting. Even though the speakers are tall, you can enjoy the three-dimensional sound image right in front of your eyes by holding your hands together. I feel like I can touch it.

Fu

It's a huge speaker system, but the top part is bowed, pointing slightly downwards, so even though it has a large mouth, it doesn't give off any sense of grandeur. If you get up close, you'll fall in love with the slimmed-down overall image. Stylish. The sound that comes out has just the right amount of warmth that gently touches the listener, and the vocals are also great. The sound of the wooden speaker system, which has been carefully tuned to the smallest detail, presents a thrilling sense of vast space and grand scale, as well as a detailed and precise depiction. This exceptionally cool figure may give the impression of a firm and calm sound, but the enclosure is not rigidly designed.

Temperature that gives you an exquisite feel of the pleasant wood texture.

It is a sound accompanied by such rich sonority. The lively and open sound of this model is also related to the fact that it has a relatively high sensitivity of 90010 for a modern cutting-edge device. Wada



DALI

LOUDSPEAKER

dali

Kore ¥15,000,000(pair)

●Model: 4-way 5-speaker bass reflex type ●Units used: Woofer 29cm cone type x 2, midrange 18cm cone type, tweeter 3.5cm dome type, super tweeter ribbon type ●Crossover frequency: 390Hz, 2.1 kHz, 12kHz ●Sensitivity: 89dB/2.83V/m ●Impedance: 40 ●Dimensions: W448×H1,675×D593mm 160kg ●Contact: D&M Customer Service Center 0570(666)112

*Preview publication: Issue 226

04

A masterpiece that greatly increases the reputation of the brand.
Really impressive sound that only a large machine can provide

Denmark, which is blessed with rich forest resources, has a thriving production of wooden furniture, which leads to the manufacture of enclosures, and Denmark is a major producer of speaker drivers (units). DALI, whose company name is an acronym for Danish-made speakers for audiophiles, specializes in introductory to intermediate models, but the company's current lineup is by far the most luxurious. Manufactured large machines. Brown corn with visible pulp pieces; It seems like Dali is equipped with a bong-shaped super tweeter, but the Kore is huge at 160 kg each.

It has an orthodox sound balance that is a little different from modern End speakers, and the sound is warm and deep, giving it a truly dignified feel. The substance of the sound image with plenty of thickness

The feeling is amazing!

FU

Almost 40 years ago, Dali It is a speaker brand born in China. Since then, its products have been widely loved not only in European countries but also in Japan. However, the company's products have expanded its market to home-use speakers, which are characterized by their reasonable size, price, and sound, rather than the so-called high-end audio market.

Suddenly, Dali and his two-person wooden machine, Kore, appeared. Contents at hand

There is a catalog that explains the machine and a simple printed

matter that claims to be a notice about the origin of the wood machine, but neither of them explains the background behind the sudden appearance of this machine. However, if you look at the catalog,

you will see that this is a large, professional machine that has been carefully constructed.

Of course, the sound also corresponds to the quality of the workmanship, with a strong and fulfilling sound that can only be expected from a large machine. This is truly a work of art that completely changes the image of Dali. Yanagisawa

When it debuted in Munich, I was blown away by the Kore's majestic appearance and realistic sound reproduction, but strangely enough, it didn't have the oppressive feeling that is common with humanoid speakers, and the sound didn't overly assert its presence. Ta. When I listened to the speakers after arriving in Japan, I had the same impression, and I was reconfirmed that the speakers had a clear band balance without any exaggeration, and that the speakers had very little distortion from the ultra-low to the high frequencies. On the contrary, I strongly felt Dali's seriousness from his plain expression.

It is not an ordinary technique to bring out such natural sound from a speaker with such a unique design, and because we have pushed the depth of low distortion to a completely different level than before, we are able to convey the reality of the artist's breathing. was able to obtain it. With the completion of Kore, Dali's reputation as a specially brand greatly increased.

Yamanouchi

LOUDSPEAKER

Arale

Remiga2 ¥11,800,000(pair)

•Model: 3-way 4-speaker transmission line type •Unit used: Woofer
25cm cone type - 20cm cone type, midrange 17cm reverse dome type, tweeter 3cm
Transmission dome type Crossover frequency: 200Hz, 1.8kHz Sensitivity: 86dB/2.83V/m
Impedance: 40•Dimensions/Weight: W545 x H1,350 x D711mm/
120kg•Notes: The finish in the photo is red, others are gray, Optical, brown, black, white available
•Inquiries: Ilex Co., Ltd. 042 (312) 2887 •Preview publication: No. 223

AUDIA, an Italian H-End audio manufacturer known for its amplifiers, started ALARE because they wanted to make speakers as well as amplifiers.

The sturdy enclosure features a transmission line that enhances the low frequency range.

If this method is used simply, the sound of both the wood bass and the kick drum will

approach the sound of a whistle, similar to that of a wind

instrument. The wooden machine has a tapered transmission line and two built-in structures that absorb unnecessary resonance, allowing the instrument to produce different tones.

The two woofer cones are lightweight and provide enough bass to compensate for the low frequencies that ordinary enclosures cannot produce.

This is a great example of the success of the Lance Mission Line. The high speed is consistent from bass to treble, and it's heart-pounding.

FU

An example of an amplifier manufacturer working on a speaker system is Krell in the US. It makes sense that this unit was developed by Audia Flight, an Italian company known for its massive power amplifiers.

This is to realize the desired sound.

Features a powerful and elastic bass range The dynamic sound is supported by two woofers of different diameters

combined with a distinctive tapered transmission. ACCUTON, which has a reputation for its ceramic midrange and 30mm diamond tweeter, is also a good choice. The vibration-damping structure of the enclosure is also elaborate, and although it is a new brand, you can feel that it was designed by an experienced designer.

Overall, it is characterized by a clear sound, and requires a lot of power on the drive side to obtain a rich low range.

Miura

Lately, I've been hearing more and more Italian brands, and Arale is one of them. However, it was not a completely new face; "Audia", which was known for its

amplifiers, had embarked on a new project to develop speakers, and this was their plan for that purpose. The product is a book

It seems that other machines are also being prepared, but so far only this machine has been affected in Japan. The unit consists of two woofers made of carbon fiber and paper of different diameters, and a small ceramic woofer. Furthermore, the 3-way configuration includes a diamond tweeter, which can be called the end of the world.

Although the sound is solid, it has a pleasant sense of expansion, and the use of a high-quality unit and enclosure is an image that comes to life. In particular, the vocals have a nice fleshy feel to them. However, the test device was a little loud, so it might not be suitable for a small room. Yanagisawa

05

An example of a successful transmission line.
Attractive dynamic low range and fleshy vocals



ALARE



MARTEN

LOUDSPEAKER

Marten

Mingus Quintet 2 Statement Edition

¥10,000,000 (pair)

•Model: 3-way 5-speaker bass reflex type •Unit used: Woofer 13cm dome type x 3, midrange 13cm reverse dome soil, tweeter/2cm reverse dome type •Crossover frequency: 370Hz, 4kHz •Sensitivity: 88dB/2.83V/m •Impedance: 60 •Dimensions/Weight: W280×H1,090×D380mm 63kg Notes: Photos The price is the statement edition, and there is also the standard specification Mingus Quintet 2 (¥8,500,000/pair) •Inquiries: Zephan Co., Ltd. 03 (5917)4500

06 Extremely beautiful and pure sound. Dynamic bass with no turbidity makes it more attractive

It has not been many years since Swedish Marten was first imported to Japan, and I cannot say that I have a firm grasp of its characteristics. When I first introduced it, I thought it was characterized by a well-honed sound that sounded as if it were made from excellent physical characteristics, but since the Parker series released two years ago, that impression has changed considerably. Because it is, how has it changed? Positive A dynamic elasticity has been added to the refined impression, making it even more attractive. Noda.

This machine is full of new charms. With this floor machine, the sophisticated world unique to Marten opens up on a rich scale unique to this class. The clear, high-quality sound that you get from the extremely beautiful surface finish is first-class. Sense of speed and texture throughout the area

It's amazing that all the photos are complete.

Onodera

Every time I see simple and beautiful Scandinavian furniture, I dream of living surrounded by them. Marten speakers, made in Sweden, have a beautiful enclosure with a glossy finish and a cone-shaped driver with a ceramic diaphragm, and many of the models are large.

The Mingus Quintet 2S is expensive, but it's a good size, and would blend well into the stylish interiors of apartment complexes in Japan's major cities.

The sound is pure and beautiful, as if all elements that muddy the sound, such as smearing and harshness, have been eliminated. The air around the speakers feels clean and purified. Along with the glossy finish of the enclosure, it's a brilliant sound that shines through, as if each particle of sound has been carefully polished.

Fu

It is said that the resonance of the cabinet has been significantly suppressed compared to the original, and this seems to be an extremely high level of improvement. Even with the previous model, the sound image blur and bass slack were minimal, and each instrument's pronunciation was outstanding.

However, the internal wiring was model with the changed specifications to the original Statement. Listening to Mingus Quintet 2 again after the change, I found that even sounds that would be difficult to notice unless you were at the performance, such as the clear low notes of the parallel piano and the instant power and momentum of the wood-based pizzicato, were beautifully reproduced. I understand that. In particular, his ability to vividly reproduce the playing of bassists who prefer strings with high tension is second to none, and the agile bass line allows him to control the tempo. I can imagine him pulling back.

The piano melody and vocals are also exceptionally clear.

Yamanouchi



ESTELON

LOUDSPEAKER

Esteron

XB Diamond MkII ¥5,800,000 (pair)

•Model: 3-way 3-speaker bass reflex type •Usage unit: Woofer/22cm reverse dome type, midrange/15.8cm reverse dome type, tweeter/2.5cm reverse dome type •Crossover One frequency: 85Hz, 2.1kHz sensing point :87dB/2.83V/m •Impedance: 60•Dimensions Weight: W420×H1,260×D590mm 69kg Note: The finish shown in the photo is gloss cobalt blue, other finishes include gloss black, matte black, gloss white. Matte and white available

•Inquiries: Arc Gioia Co., Ltd. 03 (6902) 0480

*Preview publication: No.222

07 Sharp, wide-range, and beautiful. Sing freely with a fresh tone

Uniquely shaped speaker system

Estonia's Esteron, which makes tems. The reason why they prefer using hard, highly rigid materials is probably because they are aiming for pure sound without resonance.

The company's speakers have been introduced to Japan as closed-enclosure models with a low-noise structure, but this model is a bass reflex type. Many people consider bass reflex boat noise to be a problem, but in most cases I don't notice it at all, and the rich low end actually enhances the music. Buy benefits that resonate with friends. This unit also takes advantage of this advantage, creating an extremely attractive system with the company's extremely beautiful, pure, and smooth sound, plus just the right amount of fullness. I would like to note that when new, the low-frequency braking was weak, but thanks to the importer's careful tuning, the sound has been transformed into a significantly more balanced sound.

Onodera

By incorporating the knowledge gained

through the development of the company's flagship FORZA, both this unit and the entry-level YB have been made Mark 2, and the sound quality has been further refined. All ACCUTON drivers

This machine is made up of three-dimensional sky. It offers a beautiful sound that can be described as extremely modern, with a precise sound that specializes in circular depictions. The advantage of the unique enclosure shape is that the sound image does not expand unnecessarily. The hard composite material, whose main ingredient is marble powder, no doubt contributes to the ease of separation. The rear port, which is tuned low, is probably meant to produce a deep bass sound. The trend of cutting-edge and wide-range sound is common to high-end models, and the same It can be said that the company embodies the philosophy of the company. This speaker is available in nine beautiful exterior finishes.

Miura

Eliminate unnecessary vibrations in the cabinet and other parts

On the other hand, if the vibration control is not appropriate, part of the music signal may be lost, making it difficult to convey the expression and the force of the sound. Esteron is a cabinet made of composite material with a unique composition.

It has the following characteristics and has been able to accurately suppress unnecessary vibrations. Moreover, although the technology has steadily evolved with each generation, it is not heading in a direction where speakers will no longer be able to sing. On the contrary, the undulations of facial expressions and the depth of shadows are conveyed better than ever before, and sings very well. The XB

Diamond MkII is a perfect example of this, with both the vocals and the violin having a fresh tone like a fish out of water. Sing freely.

I would also like to point out that this unit makes it easy to hear the differences in the dynamic depiction power of each amp.

Yamanouchi

LOUDSPEAKER
fine audio

Vintage Twelve

¥4,700,000(hair)

•Model: 2 way 1 Speaker/bass reflex type •Unit used: Woofer tweeter/30cm cone type/
7.5cm dome compression driver + horn type coaxial •Crossover frequency:
750Hz Sensitivity: 96dB/2.83V/m •Impedance: 80 •Dimensions/Weight: W572×H1,102x
D591mm/77.1kg • Contact: Axis Co., Ltd. 03 (5410)0071 •Preview description: No. 225

Fine in the Beatles song "I Feel Fine" is Fine, but Fine in Fine Odenoo is spelled differently and is Fyne. It was named after a salt lake in Scotland. Fine Audio is a speaker manufacturer that was founded in 2017 by members who worked for many years at Tannoy, which has a factory in Scotland, so this Vintage Twelve looks like a new product in Tannoy's Prestige series. It's no wonder you feel like it.

Although the configuration of the magnetic circuit and vibration system is different due to the addition of a new female, the driver (unit) continues to be the coaxial type that Tannoy has been using for 70,000 years. It has a furniture-like enclosure with a fine finish and an ingenious bass structure. The appearance is old-fashioned, but the sound is clear, so you can listen to any music you want.

Fu

As you probably know, "Fine Audio" is descended from Tannoy, a prestigious English and Japanese speaker company. Previously, its flagship aircraft was the "F-1-12," which made use of the Tannoy's traditional dome-type unit, but the new addition is the "Vintage Series," which consists of a total of three models, is a mid-sized machine in the same series.

I don't have time to go into details about this machine, but it is basically a legacy of the previous F-1 series machines, and it inherited the traditional coaxial unit. However, while that sound was becoming a bit more solid and solid, this one has a warm woody sound and a waving, dog-like sound. In fact, I would like to say that I don't hear it very often these days. It's special to be able to hear the barrel sound. Of course, it retains the solid sound image inherited from the Tannoy, while making it even more appealing.

Vintage Series

Fine Audio has added two new series to its lineup, the "Vintage" and "Vintage Classic," with different looks and drivers. Both are speaker groups that utilize the latest technology created by former Tannoy chief engineer (Hiroshi Paul Mills). This model belongs to the "Vintage" series, and has a classic and chic style with a surprising cleanliness. No one would be surprised to hear a new, elegant, fresh sound flowing out. Contrary to the image of the name, it is not simply a classic home-style model, but incorporates a number of the company's proud technologies, such as an isoflare driver (dual concentric) and a premium bass track port. The elegant cabinets are hand-built by craftsmen and intricately assembled from birch plywood. The beauty of the sound of wood will appeal to you with its lustrous tones that touch your heart.

Wada



From the historic furniture style enclosure
A fresh, elegant and fresh sound flows out.



FYNE AUDIO

LOUDSPEAKER

german physics

HRS 130 ¥4,200,000(pair)

•Model: 2 way 2 speakers, sealed Model: Unit used: Woofer, 25cm cone type,

tweeter · DDD type Crossover Frequency: 220Hz Sensitivity: 87dB/W/m

Impedance: 40•Dimensions: W325×H1,160×D325mm 37.4kg

Note: The finish in the photo is high polish black, and carbon fiber (¥4,500,000/pair), satin (¥3,800,000/pair), 14 colors available at an additional price.

•Contact: Taktstock 03(5848)2239

•Preview publication No. 224

German Physics from Germany has landed in Japan. The company's speakers are characterized by a DD unit shaped like a megaphone, which emits broadband and horizontally omnidirectional sound over a 360-degree radius, providing a unique listening experience. Also, the sound produced is not the usual pistonic motion (linear back-and-forth movement), but is made by using the diaphragm of a unit called Pending Wave in a claw motion. The basic principle is to create a supple tone, is a quality that is hard to find anywhere else. This machine uses a new type of DDD unit for medium and high pitches, and uses a cone-type unit for the low range as well, making it horizontally omnidirectional. By increasing the rigidity of DDD, the sound becomes even more robust and direct. Even though it is omnidirectional, it is free from ambiguity or artificiality, and yet creates a relaxing atmosphere that is unique to omnidirectional systems.

Onodera

To radiate sound 360 degrees horizontally, you can either arrange multiple drivers in a circle or install a reflector in front of driver 1 pointing upwards or downwards to diffuse the sound. Many. The former has no choice but to lower the unit price of each driver, and the latter uses reflected sound. Therefore, the high range tends to be sweet. In this respect, the German Physics method is smart and rational because even though the woofer uses reflection, it can directly radiate a wide band of 200 to 4 k pressure from a single truncated cone-shaped diaphragm.

This unit's distinctive DDD unit emits sound by integrating piston movement, bending waves, and modal radiation that occurs in the form of ripples on the diaphragm at high frequencies. A single DDD unit covers a vast frequency band of 7 octaves. The mass of the diaphragm is surprisingly light. Emit sound in 360 degrees horizontally. same For a while, company-made speakers were sold in Japan. Although imports to Japan had ceased, the bra It appears that careful improvements continued during the time period. There's no denying that the high-frequency tones are attractive, but a closed chamber is installed at the bottom of the enclosure and a 25m woofer is installed, allowing you to hear massive, weighty bass.

Wada

09

Gaining even more robustness and directness.
Unique and bewitching sound unique to omnidirectional

GERMAN PHYSIKS



LOUDSPEAKER

TAD

TAD-CE1TX ¥2,700,000(pair)

•Model: 3-way 2-speaker bass reflex type •Unit used: Woofer, 18cm cone type, midrange/Tweeter 14cm cone type/3.5cm dome type coaxial •Crossover frequency: 250Hz, 1.8kHz •Sensitivity: 85dB/2.83V/m • Impedance: 40 • Dimensions/Weight: W287 x H510 x D447mm/29kg • Note: Stand TAD-ST2TX-K (¥280,000/pair) in the photo is sold separately • Contact: Pioneer Customer Support Center (TAD Consultation Desk) 0120-995-823

Although it is difficult to tell it apart from the original, it is actually a new product that has been redesigned by reviewing all sound-related parameters, and its dimensions have changed slightly. Until now, it has been praised for its highly accurate sound, but with this unit it is clear that the ability to draw out even the smallest details has increased, and it is a speaker with excellent responsiveness that presents music more visually.

-The system is finished. The CSTF driver, which claims to be an ideal point sound source, has also been improved to make sound localization clearer and the clarity of the bass range even better. High resolution is a common feature of TAD speakers, and the well-balanced energy response from low to high frequencies allows them to express the scale of music well.

The separately sold special stand has also been improved from the previous model, with improved vibration damping and strength, resulting in clearer sound.

Miyura

It seems that eight years have passed since the previous CEL, but neither the design nor the sound feels dated at all. However, when you listen to the sound of the newly renewed CE1TX, you can hear the results of its steady evolution, and it makes you realize the depth of the speaker design.

It will be done. Uniquely designed ports that are symmetrical on both the front and rear sides bring out high-quality bass sounds that are free from so-called wind noise, and greatly contribute to a clear sound in the oven. I thought he was offering it. This time, in particular, improvements to the woofer's diaphragm have significantly improved the quality of the bass, and it was previously difficult to notice the sense of presence that spreads around the instrument and the smooth behavior of the whole tone. The background air movement can be faithfully reproduced. I feel like it has become like that. Follow every detail

The skill of putting it in is now in the realm of craftsmanship.

Yamanouchi

It has been eight years since the original CEL was introduced, and many improvements have been made within the company over the years, and after listening to this model, I was able to further refine its wide range. I understood that right away. Above all, listen to this model. The low range is very close to the lowest range, and has a sense of volume and attractive bounce that you wouldn't expect from a sound of this

size. The coaxial type that is the heart of CE1TX The stereo image produced by the CST driver is excellent, including the expression toward the back of the speakers, and I am captivated by the vividness of the tone colors and the large number of sounds. The layers of sound that spread in all directions were particularly appealing in "Waltz of the Flowers" from "The Nutcracker," and I was enveloped in a sense of euphoria. I believe that this model is the culmination of TAD's long-standing obsession with small speakers, and it is one of the ideal forms of small speakers that we have finally achieved. Wada

10 The craftsmanship has paid attention to every detail.
One of the ideal types of small speakers



T.A.D.



PIEGA

LOUDSPEAKER

Piega

Coax 611 ¥2,840,000 (pair)

•Model: 3-way 3-speaker with passive radiator •Unit used: Woofer, 16cm cone type x2, midrange tweeter ribbon type coaxial, passive radiator 16cm cone type x3 •Crossover frequency: 450Hz, 3.5kHz •Sensitivity: 90dB/W/m •Impedance: 40 •Dimensions Weight: W210×H1,170×D310mm 45kg •Note: The finish and price shown in the photo is black with a bottom plate, there is also a model without a bottom plate (¥2,750,000/pair), there is also a white model, and there is also a silver option for an additional price •Contact: Furen Coordination 0120-004-884

▶ Preview [PIEGA COAXIAL RIBBON UNIT](#)

By installing a new coaxial ribbon unit

The sound has been completely redesigned and the appeal level has been significantly increased.

Piega's "Coax 611," which was known for its simple

Swiss style and refreshing sound, has been significantly upgraded and released as the wooden machine "Coax 611." However, it seems that it is different from the previous model.

It's easy to mistake them for each other because they look exactly like each other. However, if you look closely, you'll notice that the number of 16-caliber units has increased from 4 to 5 (3 of which are passive radiators), and the size and weight have also increased. It's a shame that it's so much bigger, but even though they look similar, it looks like they've undergone some thorough human modification, especially the unique ribbon-shaped unit at the center.

Of course, the sound has also been completely redesigned.

In addition to the freshness of the previous model, the sound image is thicker and more spacious, and the volume of the voice is truly rich and free-flowing. I can say that the sense of scale of the piano and orchestra cannot be better than this. Yanagisawa said.

The ribbon unit that symbolizes Piega

The C112+ used in this machine is now in its fifth generation. While inheriting the basic structure, the re-created sound has been greatly reborn by making some of the biggest improvements ever. Although it is called the same Coax, the first impression is different from the previous series, and it is worth listening to carefully. The difference becomes even more obvious when you listen to it. In particular, the effect of being able to securely fix the magnet to the front plate has been remarkable, and the ability to reproduce time-based information such as pronunciation and rhythmic breaks in a wide range of medium and high ranges has been clearly improved. It produces a fresh and fresh tone, and the expression becomes more intense, making it perfect for rhythm instruments. Reactions are also becoming more agile.

Avoid unnecessary cabinet resonance

The technology is also next-generation, achieving quick bass with no time difference between small and high frequencies. You won't notice the weaknesses of the multi-woofer configuration in the slightest. Yamaguchi

The same width ribbon unit that symbolizes Piega has evolved into the newly developed "C112+" with this machine. The mid-range part of the coaxial ribbon uses a newly developed special coating foil to optimize damping characteristics, which appears to further reduce distortion and improve linearity.

Of course, the merits of the ribbon unit are still there, the depiction is extremely delicate, and the rich, long, airborne overtones that rise from the delicate, ultra-fine particle-like diffused string instruments and chorus have great appeal.

The volume of the low range is well balanced, and even with the powerful kicks and basses of contemporary jazz, it is surprisingly powerful without being loose. Even with this slim enclosure, the bass doesn't feel lacking in volume, the balance is appropriate, and the bass is agile, lively, and responsive. It has a comfortable bass sound. Wada

LOUDSPEAKER

Erak

Concentro S 503 ¥1,200,000 (pair)

•Model: 3-way 2-speaker bass reflex type •Usage unit: Woofer/18cm cone type, midrange/tweeter/13cm cone type JET type coaxial •Crossover wave number: 400Hz, 2.6kHz Sensitivity: 87dB/2.83V/m •Impedance: 40Ω •Dimensions/Weight: W225×H400×D372mm, 13.4kg Note: The finish and price shown in the photo is high gloss black. In addition, there is high-gloss white, high-gloss walnut (¥1,300,000-pair) available at a separate price, and special stand LS100 (sold separately) with 3 types of DCR (¥200,000-pair) •Contact: Yukim Co., Ltd. 03 (5743) 6202

•Preview publication: No. 222



ELAC

2 The warm vocals are exceptional. delicacy and A high quality machine that combines majesty

There are many examples of Elac's speaker systems that are particularly appealing not only in the floor type, but also in the compact bookshelf type, and this unit is no exception to this, being a wonderful small speaker with a high level of perfection. is high. Instead of normal piston movement, A major feature of Elac speakers is that they are equipped with a JET-type unit that emits air by pushing air out from a tooth-shaped diaphragm, and is good at reproducing low and high frequencies with plenty of energy. This unit places Takashirogawa's JET type unit in the center of the cone type unit for Ogi, achieving centralization of the sound source. I feel like I've already mastered this method, and I can hear a really smooth connection. It has a highly rigid enclosure and has an excellent response with the 8cm woofer. It is a high-quality model that combines detail and grandeur.

Onodera

A bookshelf model that inherits the coaxial driver with an AMT-type JE TSC tweeter with excellent sound penetration and the Crystal Line diaphragm from the floor-standing high-end model. Although it is the youngest member of the company's Concentro series, it is a full-fledged speaker system that achieves the rich sound quality of a top-of-the-line speaker system. Three types of coaxial driver outer rings are available, and the directivity can be adjusted by changing them. be able to. The company calls it DCR (Directivity Control Ring), and the method, which allows selection according to sound quality preferences and room conditions, is a unique approach that deserves attention. The AMT type also features a clear high range and moderately thick tonal balance. This is a product typical of the company, which has a reputation for summarizing the sounds of small aircraft.

Miura

Germany's Elac is a long-established company that once made a name for itself in the military industry, but its audio division, which started with cartridges, has made great strides and is now a well-known brand with a focus on speakers, which is now its core product. These are mid-sized machines that emphasize a homely image, and are what can be called high-performance machines that are easy to see. At the top of the list is the "Concentro" series of speakers, which is already an advanced floor-standing model - the S507, etc. are published by Yamamoto. This machine is a bookshelf that appeared this year. Although it is small, the enclosure design and units used are exactly like the high-end model Uchitani. What is particularly appealing is the sound image of the vocals, which are thick and solid, yet warm and soft. He is not an aggressive type, but he has a wide defensive range. A beaker, perfect for the living room.

Yamamoto

BOWERS & WILKINS



LOUDSPEAKER

B&W

702S3 ¥1,036,000(pair)

•Model: 3 way 5 speakers, bass reflex type •Unit used: Woofer, 16.5cm cone type
*3, Midrange/15cm cone type, Tweeter/2.5cm dome type Crossover frequency: 350Hz, 4kHz
sensitivity: 90dB/2.83V/m Impedance: 80 •Dimensions: Weight: W290
x H1,138 x D410mm 33.5kg •Note: The finish and price shown in the photo is gloss
black, and other prices include satin white, mocha, and rose nut (Y990,000/pair) •Inquiries:
D&M Customer Service Center 0570 (666)112

13

Outstanding musical expressiveness, Absolutely high quality

As I have said many times before, overall, I think B&W, a British and Japanese manufacturer, is at the top of the modern speaker manufacturers. Of course, brands that make ultra-high-end systems that don't give a clue to cost are great, but B&W is not one of those brands. By always being conscious of designs that can be mass-produced, the cost performance is unparalleled, even if relatively, and if you want top quality in that price range, the company's products are always your first choice. It is no exaggeration to say that Leni is the same. This machine is also the best puffer in this price range. It is a system that removes the performance. But it's not just that, it's of an absolute high quality worthy of a Grand Prix. Vibrant yet calm tones, smooth textures, and a rich sense of scale supported by reliable low frequencies, there are numerous

Many beautiful qualities are recognized.

Onodera

More than 5 years have passed since our establishment in 1966. B&W is now a dog speaker manufacturer with a staff of approximately 300 people at its head office and factory in the UK alone. 702S3 has a rich bass sound supported by this, the atmosphere in the sound field is floating, and the expressive power of the music is clear, which is by far the best in this class. Advanced 800D4 series in midrange The same biomimetic suspension as the Equipped with a driver that uses a pension. The frame has a sturdy ring section for attachment to a thicker, curved baffle, and the woofer uses a strong cone that is approximately 1 cm thick at its thickest point. A tweeter with a tube length similar to the 800D4 series and equipped with a carbon dome. - was placed on the top plate. The 3-way light staff is fully assembled, and the seamless sound connection is wonderful.

Fu

By incorporating the high-quality sound technology of the top-of-the-line 800D4 series, the 702S3 is capable of more sensitive and complex musical expression than its predecessors, which have earned a reputation for their high level of perfection. The new 700S3 series 3-way machine uses a continuum cone. By using this, a midrange range with high initial response and a large number of notes is obtained. The tweeter's magnetic circuit has also been improved and its aluminum housing has been lengthened. Decoupling that effectively blocks vibration transmission by the woofer along with the high range. The recording method also contributes to a clean depiction of music. It seems like it is. It is also noteworthy that this unit is the only one in the series to have a bass reflex port on the bottom, providing extended low end.

Miura



LUXMAN

SACD/CD PLAYER

Luxman

D07X ¥750,000

-Playable disc: SACD stereo, CD version -Analog sword: Unbalan
1 system (RCA), 1 balance (XLR) •Digital output (excluding SACD): 1
system (RCA), 1 optical system (TOS) •Digital input: 1 system (RCA), DSD
Original 1 Tenta (TOS), 1 USB system (B type: PCM- ~768kHz/32 bit,
~22.4MHz) •Dimensions Weight: W440×H132×D410mm. 17kg
•Inquiries: Luxman Co., Ltd. 045 (470)6991 ● Audicon description No. 221

14

The way the sound quality is refined is superb. Play music like music

Luxman's audio equipment has a unique atmosphere. I think it's fair to say that the organic warmth and atmosphere are appropriate for a rich time spent listening to music. Of course, the atmosphere alone is not enough to talk about, and the recent Luxman products have great sound quality. It is also doing very well in terms of quality. The wooden machine is one symbol of tonality. be. Nowadays, valuable digital disks. Although it is a player, there are no particular technical features other than the inclusion of a ROHM DAC element. However, the way the sound quality has been refined is superb, and the ability to play music as if it were music is extremely high, and the operability is outstanding. This unit allows you to use a more advanced digital disc player. There are many products out there, but I don't think there are many that can beat this charm. Onodera

Although there are few new disc Sony players, including those from overseas, Luxman's D07X stands out among them.
ROIM 232-bit DAC element

While inheriting the fundamental elemental technologies from the higher-end model D10X, such as dual use of the digital signal, MQA compatibility, and the LxDTM-i drive mechanism that supports TSACD/CD, this unit takes advantage of features such as optimizing the digital signal path. By increasing the precision and delicacy, it has achieved a highly precise platform that is different from higher-end machines.

The difference in output level
between CD playback (PCM) and SACD (DSD) has almost been eliminated, which means that the use of DAC elements has progressed. In addition to optical disc playback, The USB input, which supports up to 768k/2-bit PCM and 22.4M DSD, is also excellent.
Miyura

Although the price is about midway between D10X and D03X, it has a lot in common with D10X in key parts such as the DAC and mechanical drive, and my evaluation is that the sound is close to that of higher-end models. The power supply section has been strengthened, and the degree of improvement is quite large compared to the previous D06u.

What makes the D07X's sound superior is that it directly brings out the features of the performance and the highlights of the recording, as if it were focused. Recordings of local music and small ensembles convey the breath and unity of the musicians, and the orchestra gives a strong impression of the elation of the rising crescendo. Important information related to the essence of the performance. He has a high ability to bring out the best without losing it.
Created on a special day celebrating 40 years since the birth of the CD. I would like to congratulate the emergence of an excellent player that will lead to a re-evaluation of digital discs.
Yamanouchi



dCS

D/A CONVERTER

dCS

Vivaldi APEX DAC ¥5,290,000

•Digital input: Dual AES 2 systems (XLR x 4/PCM connection can be used alone), SDIF 21 systems (BNC x 2), PCM/Coaxial 3 systems (RCA x 2, BNC x 1), Optical 1 system (TOS), USB 1 system (B type: PCM/~384kHz/24 bit, DSD/~5.6MHz) •Analog output: 1 unbalanced line (RCA), 1 balanced line (XLR) •Word clock input: 3 coaxial lines System (BNC) •Word clock output: Same Pillar 1 Tentoku (BNC) •Dimensions/Weight: W444 x H151 x D43 5mm/16.2kg Note: The finish in the photo is silver, black is also available, upgrade pro from water model
•Contact: Soutai International 03 (6225)2777

*Preview description No. 223

15

The evolution of the ring DAC has reached its pinnacle. Brightly colored overtones dance wildly in the sound field space.

If there was no dCS, digital
What would have become of Le Audio?
Just thinking about it is scary. The
company's professional equipment used
to be the de facto standard in
recording studios. Many of the CDs we listen
to were produced using the company's
equipment.

The core of dCS's audio signal conversion
technology is the ring DAC. The Ring
DAC has been in use for over 30 years and
has been improved many times, but APEX has
recently undergone a major evolution.

I upgraded my beloved Rossini DAC to the APEX
version, and was amazed by its evolution. The sound
of the place cards being placed perfectly. It's the feeling
you get when you look through the lens, adjust it,
and get it in perfect focus. The same goes for the Vivaldi
DAC. The scene of brightly colored overtones
dancing wildly in front of the Fuba store seems to be calling
out to Japan's nuclear power plant.

傳

The company's patented ring DAC circuit,
a single human-shaped board that includes
everything from a discrete DAC
consisting of a PGA and numerous fixed resistors
to a power circuit, is a new design called
APEX. This is a product with an updated board
design. In addition to this unit, the Rossini
DAC and Rossini player are also APEX
spec, and existing users can upgrade for a fee.
is available.

The only difference from the previous model is the board.

However, since it is a fundamental part that converts
digital signals into analog signals and outputs them,
when comparing the old and new sound, it is
overwhelming to say that the sound quality has improved to
an extent that I have to say, I was surprised at how
well it picked up the sound, even in the smallest
areas, while maintaining the thick tonal balance
typical of dCS, which creates an imposing sound,
and with both the amount of information and the sense
of resolution, I'm waiting.

Miura

Through careful refinement, including a review
of the power supply circuit, the evolution of the
ring DAC has literally reached its pinnacle
(=APEX). Regardless of the type of media, whether
it's on disc or in a file, you can clearly hear the
evolution, but it's particularly easy to see the movement
of the lingering sound that spreads from the stage
to the entire hall, and the characteristics of the pianist's
pedal operations. Although neither is the direct
sound of the instrument, it is information that greatly
influences the impression of the performance, and
now you can hear it more accurately than before.
There is meaning in that.

There are many instances where I felt like I had
become closer to the performers, or experienced
changes in their facial expressions that I noticed for
the first time. It is extraordinary in its ability to bring
out sounds that are difficult to accurately hear with
other systems, such as moments when sharp,
almost dissonant harmonies spread out in Renaissance
vocal works.

Yamanouchi

Nowadays, we have no choice but to incorporate computers into our audio systems, but the problem is that existing computers do not give any consideration to sound quality.

TALCO of the Netherlands seems to have created SGM Extreme, a PC for audio users, through the collaboration of computer and audio professionals, overseen by a producer who is well versed in both. It is equipped with two CPUs that operate completely cool, is supported by a power supply section similar to that used for power amplifiers, and is housed in a robust chassis designed to eliminate high-frequency noise. It was developed with the assumption that it would run on Roon, and is designed to be flawless in every aspect, including denying memory operation settings and storage RA ID settings. This unit has a ferocious bowl sound that makes you feel like you can hear the future of computer-based audio.

Fu

The storage that stores digital files is NAS, and it is also the computer (core) that runs Roon. I feel that music servers like this one, which are fully connected to SB-connected DACs, are becoming recognized as a new field.

A PC machine with two high-speed CPUs. The board is equipped with a human-capacity DRAM (memory), has a built-in full-fledged analog power supply, and operates without a fan. It is an ultra-high-class product designed using an approach that is the exact opposite of the so-called power-saving design. It's a music server. What is highly praised above all else is its sound quality. Even when the same digital file is passed through this unit, it has an outstanding sense of stability, gives a sense of dignity, and produces a truly majestic sound. The storage capacity that can be specified when ordering is up to terabytes.

Mitura

I was able to hear clear sound that had been carefully removed from the turbidity from SGM Extreme, an ultra-floating music server from Dutch company Tyco

Audio. Familiar music (high resolution file) The sound quality is outstanding when I store it in this unit and listen to it. Even when it comes to music that requires a sense of warmth, such as a female vocalist, the sound is extremely transparent, but it does not have an inorganic and cool texture, and the nuances are not present. It is rich and has the warmth of human skin.

In the materials, we learned that ultra-level digital and computer-related specialists were involved in the design, and that this unit was made into a PC dedicated to high-end audio, but the audio-related features are also very good. So far, I'm impressed, and the power supply section is equipped with a large toroidal transformer. I was astonished, as if I had just come across a highly polished, high-quality power amplifier.

Wada

It's like I can hear the sounds of the future

Super awesome music server

MUSIC SERVER

tyco audio

SGM Extreme ¥5,260,000

•Input/output terminals: 3 Ethernet lines (RJ45 x 2, SFP x 1), 7 USB lines (A type x 6, C type x 1) •Storage: 280GB SSD (for OS), 2TB SSD (for Rakusan storage) •Dimensions/Weight: W483 x H180 x D455 mm/45kg Notes: Price is optional Extreme USB Card (¥310,000). Additional storage available •Contact: Taiyo International 03 (6225)2777

•Preview publication: No. 224



TAIKO AUDIO

MUSIC SERVER

DELA

N1-S38-J

¥1,200,000

•Input Terminals: 3 Ethernet systems (RJ45 x 2, SFP x 1), 5 USB systems (3.0-A type x 2, A4. type x 1) •Built-in storage: SSD 3.8TB •Clock input: 1 system (BNC, 10MHz)
•Dimensions/Weight: W440×H82×D353mm/14kg •Inter 0570(086)086 •Contact: Stock Buffalo Support Center
•Preview publication: Issue 225



DELA



Improves the sound quality of digital file playback

An ambitious work that breaks new ground

Digital file in-house production (network

Audio) will likely become the majority of music played in the future, but while it may be easy to get the desired effect, there are actually various hurdles to overcome in order for an audio file to produce a satisfying sound. One of the hurdles is how to store the sound source, and the reality is that whether it's a hard disk or a solid-state drive (SSD), the rumbling sound changes depending on the quality of the power source, the structure of the case, etc.

DELA is a high quality sound source

One of the pioneers in developing storage devices (NAS), they have steadily accumulated know-how to improve the quality of storage devices over the past few years, and this machine is the culmination of their efforts. As a result of careful pursuit of sound quality, such as a solid housing, a high-quality linear power supply, and an SSD with anti-vibration measures, you can enjoy well-balanced, authentic sound with a large amount of information. I can do it. Onodera

music library name

DELA from Melco Shinkunz has pioneered the development of audio-only NAS music servers. The wooden machine, developed as the top end of the company's most advanced N1 series, is also a product that breaks new ground in the sound quality of digital file playback.

The built-in storage is one SSD with approximately 3.8 terabytes. A newly designed circuit board is combined with an analog power supply section.

Two types of terminals (2.0/3.0) are available for the USB-connected DAC. It is also a RoomReady compatible machine.

The sound played back from digital files is characterized by high definition that focuses on the details of the sound image, and is also impressively clear with no noise. This is probably the world's first music server with an aggressive design that comes standard with a 10M master clock input. Miura

DELA has released a new top-of-the-line music server model with greatly improved sound quality. It has evolved and developed from its position as an audio NAS to a high-fidelity component, and now we are once again working on essential improvements to take it to the next stage.

This model change is made of the material of the housing. This applies to almost everything, including the structure, power supply circuit, and storage. In particular, I felt that the changes in sound brought about by increasing the capacity of the power supply circuit were not insignificant. Compared to previous models, the range for orchestras and pianos is expanded from the weak side to the forte side, expanding the scale of expression. In addition, in the vast sound field The three-dimensional localization of the instrument appears realistic, and the accuracy of spatial expression has also improved, but this is likely due to the increased rigidity of the housing and vibration control. It is interesting to see the power of analog methods. Yamanouchi

Stereo Sound

GRAND
PRIX
2022

Majestic, delicate and detailed.

Handcrafted sounds that tickle the listener



DAN D'AGOSTINO

POWER AMPLIFIER

Dan D'Agostino

Momentum M400MxV

¥13,900,000(hair)

●Yamajin: 400W (80), 800W (40), 1,600W (20) ●Input sensitivity Impedance: 2.67V 1MQ Dimensions/Weight: W318 x H133 x D546mm.43kg ●Note:

The finish in the photo is silver, others are black, upgrade support from conventional model to MxV

Service available

●Contact: Axis Co., Ltd. 03(5410)0071

●P/Review publication No. 2231



D.A.

How many years have passed since Kunie's founder started working as Dan

D'Agostino, the brand that takes its name from white meat? Its debut work was a 標榜の monaural power amplifier with a distinctive heat sink and meter modeled after the Breguet style of watches. Since then, they have produced excellent human products and established a firm position in the high-end audio world. I think their highly faithful yet unique sound, which is highly recognizable, is what keeps their fans hooked.

This machine is a supreme model that has been achieved through successive generations based on that debut work. With a high power of 400 watts, there's probably no speaker that won't produce sound. Transparent and massive, warm and delicate, deep and soft...the ability to effortlessly balance contradictory elements is a testament to the excellence of this machine. The well-crafted sound tickles the listener, and it's great to hear. Onodera

When Dan D'Agostino founded the company that bears his name, the first

thing he introduced to the world was a monaural momentum power amplifier. This machine is the latest work in its 3rd generation. Despite its relatively compact size, this monster drives even large speaker systems with overwhelming stability. It is a first-class monoblock.

The power amplifier he works on is Ever since the days of Krell, when drying was carried out in the oven, the scale of the power supply section has always been taken into consideration when designing. This machine is no exception, and its major feature is its ample power supply, which is equipped with a hanging transformer so large that it occupies half of the case volume. Another characteristic of the company's power amplifiers is that they have taken the lead in hand-crafting Ryokawa using the now classic through-hole Ryokawa board. Beautiful copper heatsink provides excellent heat transfer. Selected from a guidance perspective. Miura

Founded "Kunie" in 1980 and earned Yuna.

Dan D'Agostino was the man behind this, and since then he has released a number of popular products, mainly amplifiers. In 2009, our company made a new start, this time with the Yamara name. Therefore, although the new company's products are still limited, it goes without saying that they are all ultra-high-grade machines that are unique to Dan. This newly introduced machine is based on the M100, a successor to the relatively compact M300, which was the new company's first machine. Combining high-grade technology inherited from Torres Matched.

The result is a fairly expensive product, but the sound quality is of course high quality. The orchestra's thick reverberations can be said to be of the highest quality, and at the same time, there is no shortage of missing notes, allowing you to enjoy the magnificent, delicate, and precise reproduction. Yamaguchi



PILIUM

POWER AMPLIFIER

pyrium

Hercules

¥12,500,000(hair)

● Mountain: 350W (80), 700W (40), 1,400W (20) ● Input sensitivity/l
Impedance: 1.15V/80kΩ Dimensions, weight: W400×H410×D49
0mm 107kg ● Contact: Naspec Co., Ltd. 0120-932-455

※Review publication Issue 228



Spatial expression of unexplored areas. honest and powerful

For a long time, I had never heard of Greek-made high-end audio equipment, but in recent years it has finally been introduced to our country, and Pirium will also make its debut in Japan this year. Since the company was founded in 2014, it seems that the company has had quite a successful career.

What was delivered was a pair of ultra-dreadnought separate amplifiers, and the grand prize went to the monaural configuration power amplifier "Hercules." This unit has a power stage of 30 power transistors that provides 350 watts (8 ohms) of power. Separate the control system and amplification system from the power cable. Measures against noise are also meticulous.

As for the sound quality, it is a positive sound with an impressive brightness and freshness as if it had been exposed to sunlight. The tone is as if you are spending time in comfortable humidity, and it is honest and powerful.

Ondera

The company was founded in 2014 in Athens, the capital of Greece. Its creation became known around the world when Magico of the U.S. adopted this unit and preamplifier to play its flagship M9 in its renovated listening room in Shirakawa.

This machine weighs over 100 kg and is constructed from highly reliable parts, including a large-capacity power transformer with a capacity of 2.5 kVA, selected without regard to cost. Although the sound is vivid, it has a deep tone that gives a sense of calmness, and it makes the music lively for the dog. Dedicated power cables are used for the digital circuits and amplifier circuits that perform DC sampling of the input signal and temperature control of the elements.

His attitude is also unique.

The organizer is an audiophile who has been around for many years. He founded Pirium out of his own perfectionism.

Miura

Although Pirium is a new brand, having been founded in 2014, it has already received high praise mainly in North America and Asia, and I have heard praise for the high quality brought about by its uncompromising design approach. The names "Alexander" and "Hercules" suggest the designer's confidence, but when you touch the actual machine and hear the sound, you realize that his confidence is not exaggerated. In the case of the Hercules monoblock power amplifier, it is clear that the company was developing it with no consideration given to cost considerations, but no special care was taken in the design of the circuit or in the construction of the housing. In terms of human power, there is only one system of XL R, so it is rather easy to divide.

The highly transparent sound field, as if your field of vision suddenly opened up, is a spatial expression of an unexperienced realm. I'm buying music that is all about sound, from low volume to high volume, and shows no signs of becoming saturated with tutti. Yamanouchi

POWER AMPLIFIER

mark levinson

ML50

¥5,500,000(hair)

●Output: 425W (80), 850W (40) ●Entry sensitivity Impedance: 2.83V
30kQ (unbalanced), 2.83V 60k (balanced) ●Dimensions/Weight: W438×
World H197×D533mm. 52.2kg ●Notes: World 100 Limited ●Contact: Ha
Pairs Man International Cup 0570 (550) 465

Mark Levinson

It's a great audio brand name. He left the brand less than 10 years after it was founded in 1972, and the company he inherited has continued to produce excellent products under the brand ever since. Mr. Levinson's current product, the ML2L, was a pure A-class 25W Ogawa power generator, but it had a ferocious structure that avoided any modifications, with the output increasing as calculated as the impedance decreased. The brand's staff named it ML50, remembering the ML2L from its early days. AB class operation, human power output exceeding 100W at 8 ohm load, monoblock, white weight exceeding 30kg. Inside illuminated red from a large transparent plate I can see the part.

A calm and balanced sound. In critical situations, it exhibits the power to knock down the speaker. Limited production of 100 pairs worldwide.

Fu

To commemorate half a century since the

Mark Levinson brand was created, this is a limited edition monaural power amplifier of which only 100 pairs will be produced. It was designed at the newly established HARMAN Engineering Center of Excellence in Northridge, California, USA. The ML 50 model number is the legendary A-class monoblock. It is derived from MJ2 of Ku.

The AB class power amplifier, which secures class A operating range up to 20W (80 load), is based on the current No. 536, but has been designed to be suitable for a commemorative model. The legs with built-in isolation, which has excellent vibration damping properties, and the glass top plate are specifications unique to wooden machines.

I think the dynamic sound, which has a tendency to be light and crisp, and also has a moderate amount of tightness, is appropriate for the 50th anniversary of the historic Mark Levinson brand.

Mifura

The ML50, which was sold in a limited edition

of 100 sets to commemorate its 50th anniversary, had a strong presence as the main exhibit at the Munich high-end show. The name is also special, and the red light that stays on at all times when in use illuminates the internal circuitry is also unique to this machine. The large front handle is reminiscent of the 1020 of yesteryear, an element that stimulates the desire to own this model among fans who share the brand's glorious history. There are too many to list.

Increased power supply compared to the base 10536 I believe this is a result of the increased width, but there is plenty of room for instantaneous start-up power, and the quality of the resonance of large orchestral pieces takes my breath away. One of the special features is that the class A operating range has been expanded to 20W (8 ohm load). Most listening environments, excluding special sound sources, will often fall within this range and bring out the best qualities.

Yamanouchi



20 Limited production machine commemorating the 50th anniversary of the

company's founding. The sound will take your breath away



MARK LEVINSON

A homage to monuments engraved in history. twenty one

Deep sound that overwhelms the listener



McINTOSH

POWER AMPLIFIER

macintosh MC3500

¥4,400,000 (hair)

- Mountain: 350W (8.4, 20) • Input sensitivity/impedance: 1.9V/22kΩ (A balanced), 3.8V/22kΩ (balanced) Vacuum tubes used: 12AX7A x 3, 12AT7 x 1, EL509S x 8 • Dimensions/Weight: W457 x H300 x D549mm 54.9kg
- Contact: Electric Co., Ltd. 03:5419)1594

◆ Preview description: No. 223



McIntosh has a long history and has released many revival models of past masterpieces, and this unit is a vacuum tube monaural power amplifier with similar characteristics. It is a modern version of the MC3500, which was announced at the end of the 1960s and boasted an unusually high power of 350 watts at the time, and the model number is the same. Of course, it is not a mere copy, but has been given a modern arrangement, and the vacuum tube design has also been changed.

The company has recently been known for its new-age sounds, but this one has an even more organic and rich flavor that is more in line with tradition. Rich yet not tedious, the wonderful tonal expression and high musical resolution are the very essence of acoustic pleasure. High resolution with effective damping is good, but sounds like this one, where the reins are moderately relaxed, also create a deep and wonderful sound world. Onodera

Macintosh power amplifier

For example, I think it's an old camera with a glossy black panel (blue eyes), but the MC3500 is a little different. There are two colors: black and silver. This is the origin of the company's vacuum power amplifier, the MC3500, which was used at the legendary Woodstock Music & Art Festival (1969). It's not just a replica. This is a powerful product that incorporates everything the company has learned from designing vacuum tube amplifiers since the 1960s. The main power is 350W (2/4/8C) using 8 high and low power tubes EL-509S (no plate cap). The voltage amplification stage has a fully balanced configuration.

Comes with a careful protection circuit. 1 while weight 50

There are some nearby.

It has a stable balance with its roots firmly planted in the earth, and the elasticity of the bass is amazing. The deep and colorful sounds will make you excited.

Fu

The original model was manufactured between 1968 and 1971 and is the company's largest output tube monoblock power amplifier. The company revived the MC3500, which was used at the Woodstock outdoor concert and as a cutting amplifier, using modern vacuum tubes and technology. Having owned the discontinued original machine for a short period of time, I was very happy. The newly designed MC 3500 (Mark 2) overwhelms listeners with its warm, vacuum-tube-like feel and the deep, majestic sound supported by its abundant power. The sight of a large analog meter swinging slowly. It also feels reliable.

Although it is not possible to discern common features in

terms of circuitry, convenience has also been improved, such as support for balanced input. It is extremely meaningful to redesign the company as an homage to the monumental monuments of the past that have been engraved in the company's history.

I think it is.

Miura

POWER AMPLIFIER

Burmester

216

¥4,350,000

●Output 165W+165W(40), 490W (BTL continuous, 40)●In
Force sensitivity impedance: 0.77V/1.9kΩ Dimensions/Weight: W496
×H191×D479mm 35kg●Contact: Noah Co. ☎03 (6902)

0941

Review publication: Basic 22

Last year, Berlin-based Burmester announced the "1159", a super-class monaural power amplifier that inherited the spirit of its founder, and won the "Stereo Sound Grand Prix", but this unit is its flagship. This is the company's new generation of stereo equipment, born after experience with models. Since the company's founding, power amplifiers in this class have been given the model number "911", but the fact that the number has been changed to a new number shows the company's enthusiasm.

Output stage has 4 parallel push-pull configuration
Obtains 165 watts of power. The use of copper and metal pipes increases heat exhaust efficiency and minimizes loss, which should greatly contribute to sound quality. A clean sound with careful attention to every corner. You can feel the company's new breath of fresh air in its supple and refreshing texture. The high quality and depth of flavor are also appealing. Onodera

Last year's Signature Line's go-big 159 won the award, and the 216, which condensed that technology into a stereo power amplifier, won the grand prize. This machine,

which belongs to the top line of German Burmester, is the substantial successor to the long-running 911, which has been improved to Mark 3 in the same class. Comparing the sounds of the two, the expression of the sound that gives you a sense of Imayamaguchi is similar, but the new 216 has a large number of notes.

Not only is it overwhelming, but it also has a sound field that is clearness has also increased, accompanied by a sense of stability.

It was. SN ratio is over 109 dB

There is also a large power transformer 911 The fixing method is different. It's also a sound bar
Makes an Effective Difference in Performance
You should be doing it

By using the company's adapter, the wooden machine can also be used as a bridge-connected monaural power amplifier.

Miyura

Last year, the company released the 159, a power amplifier that was extraordinary in size, weight, installed functions, and of course, price, which surprised me. I couldn't help but brace myself for this new unit because it says "inheriting the same technology" at the beginning of Japan, but I was overthinking this, and it's not cheap, but it's a moderately priced stereo unit. However, since the style inherited from the high-end model, we are focusing on the high-end model. It makes me feel bad. However, high grade Yuzu The aircraft has been established in terms of important circuits, structure, etc. It is the only part that has been installed, and it has a variety of installed functions, etc. are omitted in this machine.

Aside from its style, the sound also perfectly inherits the features of higher-end models. First of all, what is appealing is the bright, clear, and clear sound image of the vocals. In addition, Instrument Music Mountain and Orchestra Mountain are not particularly impressive, but they have a nice scale and sense of temperature, and are comfortable without any quirks.

Yamagisawa

22

Good quality, supple and refreshing texture.
Feel the new breath of Burmester



BURMESTER

125 STEREO SOUND

Innovative design throughout.

23

Become an epoch-making model



SOULNOTE

POWER AMPLIFIER

soul note

M3 ¥3,000,000(pair)

●Output: 160W (40) ●Input sensitivity Impedance: 2V/25kΩ ●Dimensions and weight: W340×H251×D512mm. 31kg●Note: The finish in the photo is Premium Silver. Also available in Premium Black, the board in the photo and speaker cables are included.

3,160,000 yen (pair) from the order for "January 1, 2023" ●Inquiries: CSR042(703)

5100

●Preview publication: No. 221



This year was a year when power amplifiers were abundant, but one that stood out among them was the Soul Note M3. The design, which pursues the ideal power amplifier and incorporates ingenuity throughout, is sure to be an innovative and epoch-making model. That said, the basic design method is simple and rational. A driver/input stage that makes the most of the minimal output stage of a single push-pull, a non-feedback circuit that seeks time consistency, and a source of quality and quantity for energy = mountain power. I'm impressed with every aspect of this product, including the ultra-strong and high-speed power supply, and the two-piece housing that prevents vibration and prevents mechanical stress from being applied to the circuits and components.

The high-speed, high-resolution sound without any turbidity has a youthful appeal. However, a high level of taste will be required to bring out the full potential of this idealistic work.

Onodera

Soul Note's first and flagship monaural power amplifier. Born from the designer's pursuit of sound, which can be described as an obsession, this unit was completed with a non-feedback circuit and a single push-pull output from a TO3 metal can bipolar transistor. The housing structure, which separates the power transformer, which can also be a source of vibration, from the amplifier circuit is also a result of placing top priority on sound quality.

The sound of this unit, which seems to aim to precisely convert the musical signal sent from the preamplifier into electricity that drives the speakers, carefully and delicately expresses the performer's behavior. It also sensitively follows sudden changes in sound, so you can hear, for example, the emotion conveyed by a singer's music or the complex reverberations of an acoustic instrument without being aware of it. Although it is by no means stylistic, it does have a strong presence.

Miura

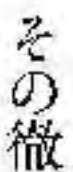
Apparently, the combination of the P3 preamplifier and this unit will be sold under the name METIS, and the sound when actually played with this set has a clear direction and consistency. One day, as I was trying to lift the M3, I remembered that the amplifier block and housing were not mechanically connected, but were independent. Although it is said to be "no fixation," the bottom  is far from being reached.

A common quality of this brand is the powerful sound of brass and percussion instruments that makes you move your body backwards, and this unit is no exception. However, it is not a thin, sharp sound, but a dense and hollow sound, and this applies not only to human sounds but also to collapsing sounds. In my instrument lessons, I was often told to use pianissimo sounds with a core rather than thin sounds, and the same goes for audio. The M3 sounds just like the theory.

Yamanouchi



ACCUPHASE

POWER AMPLIFIER

Accuphase

A300

¥2,700,000 (pair)

- Output 125W (80), 250W (40), 500W (20), 500W (BTL continuous, 8 Q)
- Input sensitivity/impedance: 1.26V/20kQ (unbalanced), 1.26V 40kQ (balance)
- Dimensions/Weight: W465×H240×D515mm 46kg
- Inquiries: Accuphase 045(901)2771

 Audition description: No. 225

24

The resulting sonic results are more than just a jump in numbers. A work worthy of 50 great years

Accuphase's 50th anniversary model

A monaural power amplifier that adorns Dell's tori. It is the ultimate culmination of the company's long tradition, both in terms of technology and design, and the utmost attention to detail has been applied to every detail. For example, how many other brands are out there that are so thoroughly committed to high quality, such as designing a new damper to create a better feeling when opening and closing the front panel cover? The company deserves the utmost praise for its attitude of never neglecting the important elements of hobby products.

The 125 watts of power with the 20 parallel push-pull output stage may seem modest, but the actual power easily exceeds the numbers, and it will be able to drive many beaker systems to its fullest. There is a certain level of sophistication to sound, and the world where you can honestly hear high resolution is a new frontier. It's a work worthy of a great decade. Onodera

Accuphase, founded in 1972, has developed several models to commemorate its 30th anniversary.

A300 is one of them. It is the company's highest grade A-class power amplifier and is the successor to the A250. It is impressive that each unit weighs 46 in monaural configuration. Most of the weight is accounted for by the power supply section and the 20 parallel push-pull MOS-FET output stage. The damping factor is officially 1400, but the firepower is over 2000.

The company develops audio amplifiers for instrumentation amplifier configurations used in medical devices that require extremely high precision. It is adopted in the group.

In the past, when the previous model was released, I was surprised by the evolution of the sound, and I was once again surprised by the evolution of the sound with this A 300. The well-defined sounds dance in a spacious sound field with a calm balance. Fu

It was almost as expected, including the model name,

that a monaural pure class A power amplifier would be released as the final product in the series commemorating the company's 50th anniversary, but it was hard to imagine that the output and S/N would increase by more than 20%. I hadn't. By following the steady development method we've been using up until now, we thought the increase would be only a few watts at most, but our expectations were borne out in a good way. The year-long preparations since the first 30th anniversary film have come to fruition. The actual change in sound goes beyond the range of numerical jumps, and the subtle changes that bring out the details.

From the smooth strokes to the wide field of view that allows you to see the whole picture, everything has evolved one step or more. One important change is that not only spatial separation but also temporal resolution has improved, making it easier to hear the driving force and sense of movement of rhythmic instruments than before. Is. Yamanouchi



UESUGI

POWER AMPLIFIER

Usugi

U-Bros 330AHWE ¥2,100,000 (pair)

Electric) products, etc. •Output: 30W (160, 80, 40) •Input sensitivity/impedance: 1V 80kΩ •Vacuum tube used: 12AX7A × 1, 6CG7 × 1, 12AT7 × 2, WE300B × 17.5kg •Note: Photos and prices are for swords, etc. equipped with WE (Western × 2 Dimensions, weight: W364 × H201 × D218mm Power tube is "U-Bros 330AHS" made by PSVANE (¥1,850,000-pair), no output tube "U-Bros 330AHL" (¥1,650,000-pair) available, vacuum tube cover optional

▼Preview description: No. 225



25

A great result of the new Japanese eel.
A dedicated power amplifier that celebrates our 50th anniversary.

Half a century has passed since Usugi's founding, which has been dedicated to producing vacuum tube amplifiers. During this time, the company's founder changed designers to two generations ago, and there has been a change in product manufacturing that incorporates cutting-edge technology, but there have been some changes in the careful method that places utmost importance on reliability. This unit is a monaural power amplifier that you would want to call the culmination of Usugi's technology. Of course, Mr. Takeshi Saji uses Western Electric, which is popular for output tubes. Two 300B direct heating triode tubes made by Kokko are used. However, Saji's unique feature is that it uses a circtron circuit instead of the usual push-pull, and the unique result of the new Usugi is that it makes use of this difficult circuit. Also, using AC ignition with less noise is a unique technology.

This is a standing heat pole tube 300B power amplifier that uses a circtron circuit, which is said to be one of the ideal tube push-pull circuits. This is the fourth time the company has worked on a circtron circuit. By firmly grasping the key points in its use, we have created a tube-type power amplifier that is full of appealing sound quality.

Western Electric's latest

This machine is equipped with a 300B straight tip. A circtron circuit with AB2 class operation provides an output of 30W, which can be considered high power. In addition to the richness of color and glossy tone typical of a direct-heated triode, it also has a robust sound that gives you a sense of its hidden power, which is a rare feature.

The Usugi Institute was founded by Yoshiro Usugi (died in 2010), who was also very active in this magazine as an audio critic. Kiki is a power amplifier that has been dedicated to celebrating the company's 130th anniversary.

"Usugi", which has been devoted to vacuum tube amplifiers for many years, has released a 300 yen power amplifier equipped with a triode made by the American company WE, which has a particularly large number of enthusiasts among true tubes. Of course, the company already has a 300B amplifier, but this one has a monaural design with a luxurious push-pull configuration, rather than the single configuration that is common in 300B amplifiers from other companies. Moreover, the output stage uses waveform synthesis inside a transformer. Synthesize externally without using a circular method. It uses a long circuit.

The sound is definitely warm and clear, and has a rich texture. What's more, each internal sound has a solid core of sound, allowing you to fully enjoy the powerful and realistic performance that you can't get with a single configuration.

In addition to water machines, the products include machines equipped with Chinese-made 300R and models without river power pipes.

A super innovative analog player. 26

Surprisingly vivid and light



ESOTERIC

AD PLAYER

esoteric

Grandioso T1 ¥7,000,000

Tone arm section (TA9D) • Model: Dynamic balance type • Spindle pivot distance: 230mm • Compatible cartridge weight: 6-38.5g Turntable section • Drive system: Magnedrive • Rotation speed: 33 1/3, 45rpm • Platter independent: 19kg • Dimensions, Weight: Main unit: W512 x H224 x D456mm 45kg, power supply section: W445 x H131 x D370mm 18kg • Note: The photo shows the model with a tone arm, and there is also an armless model (¥6,500,000). Optional arm base kits for SME, IKEDA, and Graham Engineering (¥200,000 each) and custom order arm base kits (¥200,000~) are available. Equipped with 10MHz dock input, turntable sheet included • Contact: Esoteric Co., Ltd. AV Customer Service Center 042 (356) 9235

*Covering report posted: 224/2022



Esoteric has recently become an

Although the company has been expanding its product lineup, it is a manufacturer that specializes in mechatronics, as exemplified by the SA-CD/CD mechanical

engine VRDS. This solid analog disc driver far in developing the magnetic table, magnetic force was skillfully utilized. The Esoteric Magnedrive system, patented in 2019, uses magnetic force to drive without contact. Driven by an invisible gear called magnetic force it moves. In addition, by using the repulsive force of the magnet, the load on the bearings that support the detailed and beautifully finished platter, which weighs 10 kg, has been reduced to 4 kg.

The powerful and elastic sense of rhythm is wonderful. The S/N and resolution were excellent even in the very low range, and I was surprised at how clearly I could hear the very low notes of the synth bass.

Fu

This is my first time trying a turntable, but it's an unprecedented one.

It is typical of esotericism to suddenly reach the top using new technology. Furthermore, we not only adopted a non-contact method to avoid the propagation of unnecessary vibrations, but also deliberately introduced a time-consuming mechanism to fine-tune the transmission torque. I can feel the manufacturer's willingness to take on challenges, which makes me very happy. I've heard that when it comes to analog audio, manufacturers tend to put too much effort into it, but as long as it produces an excellent product, it's worth it. I hope you will take on the challenge.

A good turntable allows you to express silence without limits, and the Grandion T1 has achieved outstanding performance in this regard. As the silence is deep, the strength of the rise is impressive, producing a vivid and unwavering sound.

Take a breath.

Yamanouchi

Super innovative analog players infused

with the wisdom of modern high-end audio technology have sprung up at Esoteric. As someone who is no stranger to the clever "gimmicks" of analog players, I was perplexed. The sound of the wood machine is surprisingly bright and light, and the sound image is as sharp and detailed as if seen through a microscope. However, it is not a hard sound, but a stable, natural sound that feels calm when you listen to it. As if to say to the listener, "Please relax your shoulders and enjoy the music to your heart's content," it delivers a feeling of joy, peace, and peace. It's very amusing to hear such sounds coming from a superheavy star-class aircraft.

10 Maka's clock sync is

This feature was made possible because of the Dew. The scenery you see through the glass changes to be as clear and realistic as if you were seeing it directly. I was moved by the organic

tone expression.

Wada



VERTERE

AD PLAYER

Valtele

SG1 PKG ¥4,800,000

Tone arm section (Super Groove PTA HB) •Model: Static balance type •Spindle pivot distance: 222.5mm Turntable section (SG1) •Drive method: Belt drive •Speed of revolution: 33-13, 45rpm Platter weight: 3.3kg Weight: Main unit: W490 x H190 x D400mm.. 23kg, Power supply: W128 x H58 x D220mm/1.3kg Notes: Optional full dust cover (¥150,000), Redline power cable (¥120,000), P-HB power supply Cable (¥400,000) Available •Inquiries: Tactstock Co., Ltd. 03(5848)2239

•Preview description: No. 224

27

Deeper and quieter.

Music unfolds three-dimensionally before your eyes

The founder of Vertere in the UK visited the factory when Roksan was still in operation. Perhaps because he grew up watching his father run a factory as well, the factory was well-maintained and there were slogans posted everywhere. It was a Kaizen method. The sincere work of precision machining must have been firmly inherited by Valtele. In fact, the gap between this SG1PKG's phosphor bronze bearing and the stainless steel front is accurate to just 2 microns, so when you fill it with oil and place the platter on it, the air inside will escape and it will sink. It takes a few minutes and costs yen.

The resonance is moderately suppressed, and the sound is so good that you can clearly feel that it converts the sound from micro grooves to high speed. I can hear so many sounds that I can't stop thinking about it. Huge amount of information. Fu

Brands that are not yet familiar to Yamamoto However, as early as last year, a Junior wooden machine was loaned to the Grand Prix. However, the model name is one letter different from this machine (last year's was MG 1), so it looks like it might be a mistake. But if you look at the photos, you'll see that it's much more advanced than the junior model. As you may already know about the company from the article [here](#) in the previous issue, Toraji Moghaddam was a founding member of Roksan, a company famous for its British-made players. Therefore, you can feel the image of the same company's machine, but even more appealing is the detailed design mechanism of the monologue. Of course, it is the same as the previous work, but instead of floating, it absorbs harmful vibrations. I get the impression that it will be taken away.

The sound can basically be said to be similar to that of Roxane, but the richness of the tone is even better. Of course, the sound's thicker sound and three-dimensional expression far exceed that of the junior model.

This machine is one of the most luxurious machines of the modern era, and is the second-highest-ranked machine from Walten, a manufacturer of analog equipment started by Toraji Moghaddam, who brought Roxane Xaxes into the world. Junior machine MG of this machine which I use habitually 1PKG's prince (body) is made up of 2 layers and 3 pieces of acrylic, but the major evolution of this machine is that the body is made of 3 layers and 4 pieces of acrylic. This single piece of acrylic is assembled in an extremely clever way to isolate (decouple) the vibrations transmitted from the motor to the tip of the cartridge. In this machine, the decoupling mechanism has evolved to be even more precise and skillful. Extremely quiet Suddenly, music becomes three-dimensional from silence. Everyone is fascinated by what is unfolding before their eyes. You must feel a shock. As a regular user of MG1PKC, I must say that I am extremely disappointed.

Wada

More than ten years have passed since Luxman resumed analog player development. The know-how that we have cultivated over that time has been put to the fullest into this unit, resulting in a wonderful product that is great to use and listen to.

The key point is the inclusion of a completely newly designed tone arm jointly developed with Saeku. The knife-edge vertical bearing is designed for sensitivity, making various adjustments easy and responding extremely sensitively. The tone is also natural, and even if you look around at all modern standalone tonearms, there are very few that are as good as this one. Another point is, of course, that Turntable-RO was created through repeated consideration of sound quality. Although it is based on the previous model PD171A, we have changed the mounting method of parts and the motor, etc., and refined it with detailed tuning. The fresh, calming, analog-like sound is surprisingly valuable. Onodera

The company, which has a long history of analog players, re-entered the market in 2011 with the PD 171. This machine is equipped with a single knife-edge universal type tone arm, which was developed jointly with Saeku Commerce, for the tone arm, which, together with the turntable, greatly affects the quality. The extremely clear sound quality trends and detailed expression down to the smallest areas are largely due to this new tone arm. I'm sure it's true.

Another feature of this unit is that a dedicated mount base for long arms can be attached to the rear left side of the player. The belt-driven drive motor is a DC type for quietness, and the audible S/N ratio is also improved compared to previous models. The platter is 5.2 kg thicker than the day I saw it. A highly complete analog platter. It's a layer.

Miura

Luxman PD171A tone

Many analog player fans were saddened by the discontinuation of production due to the end of supply of the arm. For this reason, the tone arm of Shinkai's PD191 A attracted attention, but the tone arm it was equipped with was an original universal type developed jointly with Saeku that incorporated a knife edge mechanism into the handle. The spindle, 5.2 kg heavy platter, and this tone arm are attached to a 155 mm thick top panel, which is connected to the ground via a vibration damping insulator. Equipped with a knife-edge tone arm with excellent initial response sensitivity, the reproduced sound is extremely clear and delicate, and has excellent spatial depiction. It will be done. The low range also has a stable feel. The fundamental band is rich and open. Kestra is a pyramid balance.

The mechanical beauty of the tone arm makes the overall design stand out and really shines

It's an excellent machine that shines brightly.

Wada

28

You can use it, you can listen to it.

Extremely complete analog player

AD PLAYER

Luxman

PD191A ¥900,000

Tone arm section (LTA710) •Model: Static balance type •Spindle Vivo
Between pieces: 240mm •Compatible cartridge weight: 4~11g Turntable section •Drive
Method: Belt drive •Rotation speed: 33, 1/3, 45, 78rpm •Platter white weight:
5.2kg Dimensions/Weight: W491 x H123 x D399mm.24.8kg Notes:
Head shell included, optional dust cover, heavy weight, various arm bases available
•Inquiries: Luxman Co., Ltd. 045(470)6991 •Preview publication: Issue 225



LUXMAN

The latest cartridge from Phasemation, which has continued to develop analog components since the brand's launch. Up until now, the company has had the impression that the company has focused its lineup on relatively reasonably priced products, but this machine has stepped into the ultra-high-end realm, creating an excellent product that symbolizes the company's new generation. The

most distinctive feature is the diamond.

The company's first use of cantilevers, Rikawa selected the material with the highest hardness in order to transmit the tonal vibrations picked up by the needle tip to the power generation coil without loss. Since it is less arrogant, the design must be more severe in various parts such as the damper, coil, and lead wires, but it has been carefully tuned. The sound is characterized by an incredible amount of information and crystal clear transparency. The scale is wide and deep, and this is a wonderful sound. Onodera

Recently, the topic of cartridges has been Dia. It feels like I'm concentrating on the Mondo cantilever. This can be seen as a result of improvements in Japan's main-made diamond manufacturing technology. This new flagship model

from Phasemation is also the company's first to use a diamond cantilever. The aim is to increase the speed at which faith spreads and obtain more information. In addition, the stylus tip is also made of natural diamond, which is a tradition for the company's machines, and the precision of its installation has been improved from 5 degrees of previous models to 3 degrees. 

It is said that this will enable even more flexible tracing capabilities. Since the experience was in the company's listening room, which I was not familiar with, and it was not possible to compare it with previous models, I was unable to fully experience the results. However, it is true that the sound was of high quality, especially 

I was left with an impression of how clear he was.

 Rikawa

Phasemation's MC cartridges are not only widely used among record fans, but are also often used in professional settings such as studios and listening rooms of various companies, giving the brand a high level of trust. For this reason, expectations were high for the company's long-awaited new model, and the author carefully examined the LP records he had brought with him for trial listening.

If I were to describe the playback sound of the PP5000 in one word, it would be a sound that stays strongly in your memory once you hear it. The greatest beauty of the music, which leaves a vivid impression on the listener's ears even for a short time, is its strong penetrating power, and you can imagine that both of these powers are brought about by the combination of the diamond cantilever and the natural diamond tip. Needless to say, ingenuity to enhance the material properties of diamond, such as a magnetic circuit that improves the uniformity of the magnetic field and a body coated with titanium nitride, plays an important role. 

 Yamanouchi

Once you hear it, it stays in your memory.

2 Absolutely high-quality sound

PHONO CARTRIDGE

phasemation

PP5000

¥1,350,000

•Power generation method: MC type • Output voltage: 0.3mV (5cm/sec. 1kHz) ●
Internal impedance: 40 • Needle: 1.7~2.0g • Weight: 14.3g •
Contact: Kyodo Yukiko Engineering Co., Ltd.) Phasemation Sales Department
☎ 045(710)0975 •Preview publication: Issue 225



PHASEMATION

PHONO CARTRIDGE

ortofon

MC Diamond

¥1,180,000

•Power generation method: MC type •Output voltage: 0.2mV (5cm/sec, 1kHz)•Internal Impedance: 60 Needle force: 2.6g
•White weight: 17.5g Destination: Ortofon Japan powder
Inquiry 03(3818)5243 •Preview publication: Issue 225



ORTOFON

30

The product of enormous effort and clever design.

The spatial description gives an unparalleled sense of openness.

Since I was listening to the first track on the disc, I lowered the needle to the beginning of the outermost track, but I couldn't hear any surface noise, and suddenly the first track began. Usually there is a noise intro before the music intro, but MC Diamond doesn't have that. No, it's a type of cartridge that does make noise, but you can't hear it.

A cart that traces microscopic pitches

The ridge is in great turmoil with multiple dissolutions and multiple resonances. The diamond cantilever, exquisitely described as the "forbidden fruit" on Ortofon Japan's homepage, eliminates the loss of "deflection," and the fulcrum of vibration is clearly defined by the specially formulated rubber and damper structure. This machine is the product of enormous effort and thoughtful design, including the ability to hold down and apply braking. It's a beautiful sound that shines smoothly and smoothly.

Fu

Already has 3 types of diamond manufacturing capabilities. The company that brought out the centimeter machine has now added another model, the "MC

Diamond", which uses a diamond cantilever. The core type winding is the same as the "MC centimeter", which has been representative of the series, and the same machine. Ultra-high-purity oxygen-free copper wire, which was used in winding wires by companies such as Co., Ltd., is also being used in a similar way. In addition, a unique feature of this machine is the use of a newly developed damper that incorporates carbon particles called "Multi-Wall Carbon Nanotubes" into a rubber material, which eliminates unnecessary resonance. It is said to have even better performance in both "braking" that suppresses the cantilever and "support" that accurately holds the

cantilever. And the sound is transparent and grainy. Not only does it have a good sound quality, but it also has a well-centered, lively sound that is truly appealing. Naturally, it has a strong sense of engineering, but part of its appeal is that it doesn't overemphasize it. Yanagisawa

Solid single diamond on canchin bar Denmark's Orthof, which adopted Mondo Von's flagship model. In Elgar's

"Cello Concerto," Jacqueline du Pré's passionate emotion hidden within, as well as the cello's extremely delicate, clear, and high-quality tone, smoothly penetrate deep into the listener's heart. It doesn't have the hard feel you imagine when you hear the word diamond. The orchestra's tuttenno is also surprisingly dynamic. The spatial description was a sense of openness that Oi had never known before, and the sound of this unit, which I would like to call transparent and noble, had an extremely long lingering time in the air, delivering a deep sense of peace and a mesmerizing sweet moment. The contemporary jazz song "Blue Note All Stars" exploded with a hot and powerful beat that lowered the center of gravity. In short, no matter what program source the music you listen to will deliver great emotion. That's true.

Wada

DS audio is the Japanese audio

Optical cartridges that were buried in history

It is a great achievement for him to make this discovery and spread products using this method around the world. In the hobby world, the more options you have, the better your experience is, and optical cartridges have a different sonic world than regular magneto-cardiac cartridges. The company's products are now in their third generation, with significantly improved S/N sensitivity and faster response times, and this is a model that fully embodies the characteristics of this third generation in the form of sound. It is le. The flagship Grandmaster is a high-end machine, but the fact that we have been able to successfully incorporate its technological achievements into junior machines is the result of our continuous efforts.

A sound that is well controlled

throughout the range, yet free of unnecessary tension. It's a good sound with good visibility and lots of energy.

Onodera

Former photoelectric phono cartridge

DS Aude, revived with modern technology.

This is an optical cartridge with a third generation design by lo. There was also an equalizer amplifier D SIW3 equalizer exclusively for optical cartridges that was announced at the same time, and including that, five companies in Japan and overseas have now released compatible equalizer amplifiers. The optical cartridge is only available from DS Audio, but it is the second method to join the conventional M M type and MC type. I feel like it has become established.

The Grandmaster, which is equipped

with a round diamond cantilever, is the top model of the optical cartridge, but I think this model, which has a boron cantilever, is superior in sound quality in some areas.

Since the tips of the needles are different,

I have to admit that this is just a sensual impression, but I was left with a good

impression from the core.

Miura

Independent left and right light source LED and sensor

The 3rd generation optical cartridge structure has improved separation and reproduction of intervening information compared to conventional models, and the output of this unit has increased by 1.5 times. By raising the basic performance to that extent all at once, the aim is to spread the advantages of optical cartridges widely, and the DS-W3, positioned at the core, will play a major role. Equalizer 1 W3 was also introduced at the same time, but since you can also choose from other companies' products, this time we decided to award the grand prize to the cartridge alone, but we also saw a significant evolution from the previous work when used in combination with the same equalizer.

I would also like to add that

There is no fluctuation in the sound image localization of the voice and melodic instruments, and it is very comfortable to have the sound firmly in focus. Whether it's jazz vocals or soprano arias, the voice will bring out the best of this unit regardless of the genre.

Yamanouchi

The sound fully embodies the characteristics of the third generation.

Natural and full of energy

31

PHONO CARTRIDGE

DS audio

DS-W3 Cartridge

¥450,000

•Power generation method: Photoelectric type •Output voltage: 70mV (3.54cm/sec, 1kHz)•Stylus force: 1.85~2.05g (appropriate stylus force: 1.95g)Double: 7.9g•Contact: Stock Digital Stream
☎042(747)0900 •Preview description: No. 225



DS AUDIO

Critics Applause Critics' Applause 2022



01



02

among the nominated products. an applause to all the critics from person. Critics would like to give with a maximum of three models per Applause will feature 15 models, Le. As a result, this year's Critics It has become Now let's talk about each model's recommendations.

LOUDSPEAKER

krypton

KX3SX ¥398,000 (pair)

•Model: 2-way 2-speaker, sealed type •Unit used: Woofer 17cm cone type, tweeter 3.5 cm ring type •Crossover frequency: 3.5kHz •Sensitivity: 87dB/W/m •Impedance: 60 •Dimensions Wide weight: W224 x H380 x D319mm 10.8kg Note: The stand in the photo is sold separately

Preview publication: Issue 225

LOUDSPEAKER

Piega

Coax 411 ¥1,500,000 (pair)

•Model: 3-way 2-speaker bass reflex type •Used Unit: Woofer 16cm cone type, midrange / Tweeter ribbon type coaxial •Crossover Frequency: 450Hz, 3.5kHz Sensitivity: 90dB/W/m •Impedance: 40 •Dimensions Weight: W210 x H450 x D310mm/25kg •Note: The finish and price shown in the photo is black, white is also available, and silver is available at a separate price (¥1,400,000/pair). The special stand shown in the photo is "Stand 300 (¥260,000/pair)" sold separately •Contact: Furen Coordination •Listening 0120-004-884 record published: Issue 225

we will ask you to initiate the discussion. To do. Of course, if you agree with the opinion, Please talk to me.

01
KX3SX

that continues to produce speakers while Miura Krypton is a Japanese manufacturer. However, the designer was originally from Victor Japan.

We have painstakingly improved the system, which has its roots in the SX3, which was once developed there and became a hit with people. The KXXSX places the highest priority on sound quality, and has reworked the key technologies of the SX3 from a modern perspective, including an expensive alnico magnet magnetic circuit, a Kurt Muller woofer cone, and a particle board structure enclosure, making it ideal for music sources. This is a great speaker with improved responsiveness, and I would like to mention it here as a product worthy of Critics Applause.

02 Coax 411

Editorial Department Piega's COAX 411 was recommended by three people.

Fu: The characteristic of Piega is that it has a ribbon-shaped interior.

It is in the Takagi unit, but this time the new coaxial unit The Gen2 series has been released by developing the cut. The tallboy model was chosen for the grand prize, but this smaller machine also did very well. Due to its high rigidity, which is unique to its small size, it also has an excellent connection with the woofer. Wada: One of the charms of the ribbon type is its delicacy, but this unit has a sense of power attached to it. Yanagisawa Yes. It also has the same-sound feel as a tallboy model, and on the other hand, it can even outperform higher-end models in terms of cohesiveness. I thought it was a good speaker.

03 Contour 601

Yanagisawa: Speaker systems have seen great progress in recent years.

I talked about this in the general discussion, and I think Dynaudio's products are a good example of this.

Onodera: The recent improvement in the sound quality of the company's speakers has been remarkable.

Yamanouchi: I think we are seeing scientific results from the construction of a new large-scale measurement facility. Yanagisawa: I thought this was a speaker system that delivered rich, rich sound with excellent texture.

04 SL-G700M2

Yamanouchi: At a time when digital disc players are not readily available, the emergence of an excellent device like this one is valuable as a valuable option, and it is also a significant improvement in sound quality from the original device.

I am accomplishing it. What's more, it's amazing that it supports not only discs, but also digital files, streaming, and various other forms of media. •Listening

03 Onodera mark and model

However, it is a highly complete product that uses advanced digital technology to perform new signal processing that improves the reproducibility of impulse signals, and has been subjected to steady analog-like fine tuning throughout. It's a player.

03

LOUDSPEAKER

Dynaudio Contour 60i ¥1,650,000 (pair)

•Model: 3-way 4-speaker bass reflex type •Unit used: Woofer 23cm Cone type x 2, midrange 15cm cone type, tweeter 2.8cm dome type Crossover frequency: 300Hz, 4.5kHz Sensitivity: 88dB/2.83V/m •in Beadance: 40 Dimensions/Weight: W343 x H1,359 x D454mm 54.3kg

(5542)3545



04

SACD/CD PLAYER

Technics SL-G700M2 ¥370,000 (tax included)

• Playable discs: SACD stereo, CD, etc. • Analog output: 1 unbalanced system (RCA), 1 balanced system (XLR) • Digital output (excluding SACD): 1 coaxial system (RCA), 1 optical system (TOS) • Digital input: 1 coaxial system (RCA), 1 optical system (TOS), 3 USB systems (A type x 2: PCM...384kHz/32 bit, DSD... 11.2MHz, B type: PCM... ~384kHz/32 bit, DSD... ~11.2MHz), 1 Ethernet system (RJ45) • Dimensions/Weight: W430×H98×D407mm 12.3kg • The finish in the photo is silver, others are available in black • Inquiries: Panasonic Co., Ltd. Customer Service Center 0120-878-982

*Preview description: Issue 225



05

SACD/CD PLAYER

CH Precision D1.5 ¥5,550,000

• Playable discs: SACD stereo, CD, etc. • Analog output: Unbalanced 2 types of powder (RCA, BNC), 1 balance system (XLR) • Digital output: 1 coaxial system (RCA), 1 balance system (XLR), 1 Ten line (TOS), 1 CH LINK system • Dimensions/Weight: W440×H160×D492mm 27kg • Note: Price is for D1.5 Player with analog board. There are various boards such as clock interface board (¥180,000) as an option, and D1.5 Transport with only digital power. (¥4,900,000) Yes • Inquiries: Stock Zephan 03 (5917) 4500

*Preview description: No. 222



06

DIGITAL FILE TRANSPORT

Lumin U1X ¥1,331,000

• Digital input: 1 Ethernet line (RJ45) • Digital output: 2 coaxial lines (RCA, BNC), 1 balanced line (XLR), 1 thread line (TOS), 2 USB lines (A type) • Supported file format: DSF, DFF, AIFF, ALAC, FLAC, WAV, etc. • Supported sampling frequency: PCM... ~768kHz/32 bit, DSD... ~22.4MHz Dimensions Weight: Main unit: W350 x H60 x D345mm/8kg, Power supply: W106 x H60 x D334mm . 4kg • Notes: The price shown in the photo is black, and silver is available at a separate price (¥1,210,000) • Inquiry stock Brightone 050 (6877) 6043

*Preview description: No. 225

Fig.: There is not much difference in appearance from the previous model.

sound has greatly evolved, with higher resolution, powerful feel. However, the change in the DAC element gives it a more charm. Miura: In terms of sound quality, the But his almighty ability to do things is also a great



the digital players that made it to this year's nomination list. three models of CH Precil disc players, Onodera was one of one is basically the D1/5. Although this unit was one of only version of the DI that was John's debut work, and the third drive content is almost the same. Therefore, the D1/5 is an improved reliable. Currently, the dynamism remains the same, and the disk Due to the change in mechanism, the skeletal structure is more

It is characterized by an increase in I think his presence is still very appealing.



technology of digital file playback equipment. actually a computer expert. It becomes the core a professional who knows computers well is be able to create great products without people, and make it sound good. I believe that we would not some computer noise, but that alone doesn't does. If you listen to the Lumin model, you'll hear feel strangely aware of the high specs. It machine has that kind of quality that makes everyone of the disc reproduction era, but this It often has a warmth and richness that is reminiscent

There is also an that lets you listen to Paso resolution sound. After all, file playback is a good product mean you could just plug it in and call it a day.

umbrella. I thought it was a product that didn't I really feel that. However, when Since it is a port, the sound quality depends on the connection. A converter that adjusts the environment, and Miura: This is a transformer. conditions. In the first place, file playback is highly dependent on the D/ than you might think, and the sound changes a lot depending on the listening in a proper environment, it is much more difficult to prepare

You can see that it is a product.

Yamanouchi Digital File Transport is also a model. sound is very different depending on the "ru". This Jean The word "ru" may have a big meaning in the future. The Hmm.



Fu: Macintosh has a long tradition and a strong individuality. has a unique personality, which is why there are so many fans. sound of products has changed in a good way, and the brand past, it was all about the air in the room, but in recent years, the sound is so deep that it almost resembles a Macintosh. In the However, with the addition of transparency and delicacy, I think the are becoming more and more special.

Yanagisawa: I think the company's products of appealing to more people has disappeared. to more people has disappeared, but the idea sense, it has been said that the idea of appealing addictive. That said, it's unique. In a good color of the color has been lost, but it has become I think that's amazing. It doesn't mean that the Onodera: This C12000 is not like that. worlds. modern mackintosh sound which combine the best of both and vacuum tube amplification circuits, It is a symbol of Miura semiconductor It is also a feature that it is it through a vacuum tube, it becomes active. I think it gives off a nice sense of color. By passing

its existence. However, the seasoning is exquisite, and the preamp It's a product that makes you feel the significance of



Epsilon is this brand.

Onodera Greece's

with its monophonic, warm, and refreshing tone

However, this unit is packed full of that charm

It is a real machine.

It's true that the sound is warm but refreshing. and texture. It's difficult to balance both.

The one that pulls it off effortlessly is the one that does it all.

Among this year's many excellent Ppsilon power amplifiers, Onodera:

But I think it's a river-colored result.



easy as possible and with good sound.

audio, and this book makes it as

We are proposing a new way to enjoy



07

PREAMPLIFIER

Macintosh C12000 ¥2,300,000

- Insertion sensitivity/impedance: 450mV 25kΩ (unbalanced), 900mV/50k (balanced), 0.25~4.5mV/250~47kΩ (phono) Used vacuum tube: 12AX7A×6, 12AT7×4
- Dimensions/Weight: Main unit/W445 x H152 x D441mm. 11.3kg, power supply section/W445 x H152 x D441mm 12.3kg
- Inquiries: Stock Electric 03 (54 19) 1594

*Preview publication: No. 224



08

POWER AMPLIFIER

Epsilon Aelius 2 Mono SE ¥7,800,000 (pair)

- Output: 200W (80), 350W (40) • Vacuum tube used: EC8010×1, EZ81×1 • Input impedance: 47kΩ • Dimensions: W425×H230×D425mm 45kg
- Inquiries: Stock Stella 03 (3958) 9333

*Preview publication: No. 224



09

INTEGRATED AMPLIFIER

Marantz Model 40n ¥260,000

•Model: Integrated amplifier with built-in digital file player •Output: 70W+70W (80), 100W+100W (40) •Digital input: 1 coaxial line (RCA), 1 optical line (TOS), 1 HDMI line (ARC), 1 Ethernet line (RJ45), 1 USB line (A type) •Analog input: 1 MM phono line (RCA), 3 unbalanced lines (RCA) •Supported file formats: DSF, DIFF, ALAC, FLAC, WAV, etc. •Dimensions/Weight: W443 x H130 x D432mm./16.7kg •Notes: The one in the photo is black, others are silver and gold •Inquiries: D&M Customer Service Center 0570 (666) 112

•Preview publication: No. 222

incorporate network player functionality into the in-amp. Prime compatibility with video equipment and the ability to excellent. This type of product is characterized by its high very easy to use. Of course, the sound quality is also its good qualities. Fire is very common, but it is rare, so it is I would like to recommend it here, considering

10

Evolution

Yamanouchi Triode is an amplifier that utilizes vacuum tubes, but this integrated amplifier of this work is volume, which is rare for vacuum tube amplifiers, He is famous for exploring electronic You're making great progress. able to eliminate the unavoidable internal wiring. By adopting the Miura electronic volume, we were



10

INTEGRATED AMPLIFIER

Triode Evolution ¥500,000

•Output: 40W+40W(80) •Vacuum tubes used: 12AU7×2, 12AX7×2, KT88×4 •Input sensitivity/impedance: 320mV/100k •Dimensions Quantity: W440×H210×D330mm 30kg •Contact: Stock Triode ☎043 (940)3852

•Preview description: No. 221

improved. Channel separation and gang errors (left and right) tube a channel volume difference has also been greatly This is reflected in the sound quality, and the attractive vacuum and have become a great powerhouse. Yamanouchi: I also think that the transformers installed are excellent It also contributes a lot to the sound quality.

11

Selekt LP12

LP12 is a super song that everyone is familiar with. product with a wide variety of variations Rin Wada's Compact, not exaggerated, and has real depth A long-selling player that lets you hear the high quality of analog music? It has been loved for many years as a player, but is this a is equipped with a newly developed tone arm. Yamanouchi: This is a new product in the series that



11

AD PLAYER

Lin Selekt LP12 Y1,775,000

Phono cartridge section (Kendo) • Snow power type: MC type • Power voltage: 0.45mV (3.54cm/sec.1kHz) • Internal impedance: 120 • Positive stylus pressure: 2g White weight: 7.6g Tone arm section (Arko) •Model: Static balance type •Spindle to pivot distance: 211mm Compatible cartridge weight: 2~10g Turntable section •Drive system: Belt drive •Speed of revolution: 33-13, 45rpm •Platter speed: 3.75kg •Dimensions and weight :Thick body • W445×H140×D356mm 10kg, power supply (Lingo 4) W75×H65×D312mm 1kg •Note: The finish in the photo is black, other various finishes are available •Inquiries: Porin Japan 0120-126173 •Listening record posted: No. 224

That's a characteristic. bearing assembly. Although it was not developed this year, with high sinterability and precision, thanks to the new CELL the benefit of this is that we have created a new center spindle overall sound quality of the spindle has greatly improved, and to feel the long bottom with this device. The Wada: It's compact, cute, and has great sound. I was able A wonderful analogue programmable to keep and use. It's a layer.

12

AT-ART20

Audio-Technica is celebrating its 60th anniversary this year. — for audio. This machine is called a commemorative model. Although it may not be the case, it symbolizes the company's passion



12

PHONO CARTRIDGE

audio-Technica

AT-ART20 ¥300,000

•Power generation method: MC type • Output voltage: 0.55mV (5cm/sec, 1kHz) Internal impedance S: 120 Sat: 1.6~2g (proper needle pressure: 1.8g) White hand: 9g •Inquiries: Audi Otechnica Customer Relations Desk 0120-773-417 *Preview publication: No. 223



13

PHONO CARTRIDGE

Fidelix

MC-F1000 ¥400,000

•Power generation method: MC type • Output voltage: 0.18mV (5cm/sec, 1kHz) • Internal impedance S: 60 • Group: 1.3~1.6g Monthly hand: 8.4g • Notes: Head shell "MITCHAKU" and Tyrus cleaner "SASUPA" included • Contact: Yufidelix 042 (493 7082) *Preview publication: Issue 223



14

PHONO CARTRIDGE

Ikeda

Akiko ¥777,000

•Generation method: MC type • Output voltage: 0.35mV (3.54cm/sec, 1kHz) • Internal inbee Dance: 60 • Stylus force: 1.75~2g • Weight: 15g • Contact: Kajihara Lab Go 03 (6279)6311 • Preview published: Issue 223



15

PHONO EQUALIZER

DS Audio DS-W3 Equalizer ¥850,000

•Phono equalizer for DS audio optical cartridge • Dimensions Weight: W450 x H120 x D435mm, 13.5kg • Notes: 4-stage low cut-off switch Possible • Contact: Digital Stream Co., Ltd. 042 (747)0900 • Listening

Information: Issue 225

and delicacy of a monologue's dual-coil system. sound quality. A cartridge that combines the power Coupled with the feeling, the result is excellent

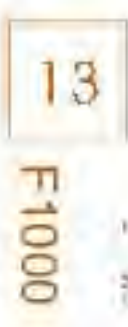

F1000

air-core MC type. is the ultimate in

Miura: This cartridge

the structural ideal of several products.

material Onodera: This type of method has already achieved using advanced techniques, but with Fidelix, the base coil itself has been completely eliminated and installed at it with a magnifying glass, you're truly mesmerized. The That's right. It's amazing. Miura: It faithfully reproduces the sound groove of the encoder, and when you look

and direct sound, similar to that of other cars. from Torridge. Onodera: I was impressed by the clear There is something completely different

Miura: The information is amazing.

yet, it has a fine texture that is unique to Japanese products.

A cart that is delicate and full of monologue charm. And

I think it's Ridge. Onodera:

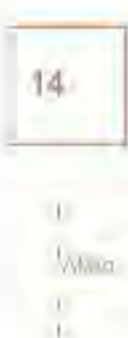

14

Miura's current product uses a diamond cantilever.

had cartridges released by multiple manufacturers, but planet, and this one is one of them. Ikeda originally direct-type cartridges without a cantilever on the which is a hard material, and this was one of the first Both cartridges were made with a diamond cantilever,

and has achieved a clear sound by using it. Ikeda's wonderful model that has opened up a new dimension Did. It is a

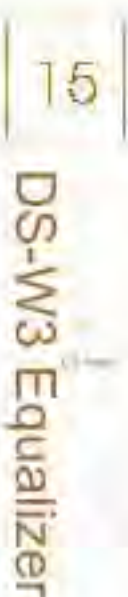

DS-W3 Equalizer

Wada Optical cartridge promoted by DS Audio with optical cartridges are being praised all over the world.

is. I think the wonders of phono-collages that are compatible

Several manufacturers have appeared to developers.

cartridge is proof of this.

normal one, and the fact that it goes to the

the Senkawa circuit is different from the

Since a power supply function is also required,

is not it.

Wada: Under such circumstances, this unit is the original.

crafted. DS Audio makes the most of its past experience.

I think it's an excellent equalizer that has been carefully

is.

Miura Accumulating know-how and stimulating other companies' products

It may be because I received it, but in various mountains

company's previous products.

youthfulness has improved the sound quality of the

more and more attractive. Wada: The fresh

Now, the world of optical cartridges is becoming

It became a target.

session for the Leo Sound Grand Prix.

time today. We are now closing the selection

I'll eat it. Thank you very much for your

did.

EXPERT PRO

AUDIOPHILE EVOLUTIVE SYSTEM

あなたが指揮するオーケストラ



Expert Proオンラインコンフィギュレーター

あなたのシステムを思いのままに操る

3系統の入力端子はそれぞれデジタル入出力、アナログ入出力を自由に選択できます。
マルチチャンネル、デュアルモノでアクティブフィルターを設定できる他、
フォノ・ステージを精密かつ正確に設定することも可能です。
お手持ちの機器の性能を最大限に引き出すパワーが手に入ります。

UPnP

roon
soby

A I R®

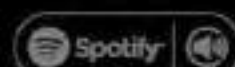

Expertオーナーの方へ

Core Infinityを搭載したExpert Proへのアップグレードをご用意しています。
更なるパフォーマンスの向上、新たなストリーミング機能をお楽しみください。

WWW.DEVIALET.COM

DEVIALET

INGÉNIERIE ACOUSTIQUE DE FRANCE

EXPERT PRO

AUDIOPHILE EVOLUTIVE SYSTEM

Evolution to the next stage



EXPERT 1000 PRO DUAL

An ultra-compact hi-fi system that maximizes information from components, networks, and music sources.

SAM

SPEAKER ACTIVE MATCHING

Measures and records the operation of the speaker unit. Based on this data, Expert Pro is able to optimize speaker operation and precisely synchronize the woofer with the music signal recorded in the sound source. Over 900 types of speakers are compatible with SAM. By maximizing the potential of your speakers, you can experience the emotion of music just as the artist intended.

RAM

RECORD ACTIVE MATCHING

The online configurator allows you to configure settings to match your cartridge. Equipped with over 256 cartridge-compatible presets and 13 RIAA equalizer curves, the RAM plays your favorite albums under the best conditions.

CORE INFINITY

NEW SMART CORE

Core Infinity makes Expert Pro compatible with the latest streaming services. Core Infinity is equipped with the latest version of Devialet OS (DOS), supports ROON READY, and can use streaming protocols such as UPnP, AirPlay®, and Spotify Connect (wireless Ethernet). Additionally, software updates allow you to keep up with the latest technology that will be announced in the future.

EXPERT 1000 PRO DUAL: Maximum output 2 x 1000W/60 or less, THD+N 0.00025% (at maximum output), S/N ratio 133dB (dual mono configuration)

Stereo Sound
Grand Prix
2020



www.devialet.com

DEVIALET

INGENIERIE ACOUSTIQUE DE FRANCE



SILENT ANGEL



ネットワーク演奏に
歓喜と静寂を

ネットワークオーディオ用OS "VitOS" 搭載ミュージックサーバー **Z1**

color: ブラック/シルバー オープン価格

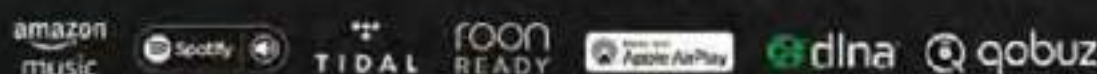

ヘッドフォン端子/アナログ出力端子搭載
Hi-Fi Network Streamer

B1

color: ブラック オープン価格



Hi-Fi Network Streamer

B1T

color: ブラック オープン価格



ヘッドフォン端子/アナログ出力端子
DAC搭載 Hi-Fi Music Transporter

M1

M1: メモリ8GBモデル M1-4GB: メモリ4GBモデル
color: ブラック オープン価格

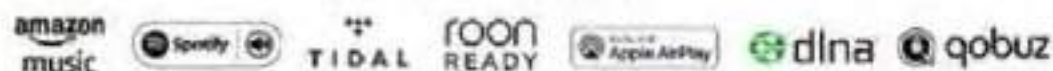

Hi-Fi Music Transporter

M1T

M1T: メモリ8GBモデル M1T-4GB: メモリ4GBモデル
color: ブラック オープン価格



輸入販売元



完実電気株式会社
KANJITSU DENKI CO., LTD

本社 〒101-0051 東京都千代田区神田神保町 3-25 住友神保町ビル 大阪営業所 〒532-0011 大阪府大阪市淀川区西中島 2-14-8 新大阪第2Fビル
製品に関するお問合せ先 サポートセンター: tinfo@kanjitsu.com TEL.050-3388-6838 受付時間: 平日10:00~18:00(土・日・祝日・夏期休暇・年末年始・弊社休業日を除く)

ダイレクトドライブの進化は、
止まらない。

Technics

Rediscover Music

Technics

圧倒的な性能で、豊かなレコードの音をありのままに再現する、新リファレンス。

かつて、ダイレクトドライブを生み出したTechnicsが、現代の先進技術、素材、そして情熱を惜しみなく注ぎ込み、次代に向けた一台を、再発明した。SL-1000R。測定限界に迫る回転精度を達成した、Technics 史上最高傑作を、いま、あなたに。



[受注生産]
ダイレクトドライブターンテーブルシステム

SL-1000R

メーカー希望小売価格 1,760,000円(税込)

*ヘッドシェル、カートリッジ、フォノケーブルは付属していません。

●ご購入の際は、必ず「保証書」の記入事項をご確認のうえ、大切に保管してください。●ご使用の際は、必ず「取扱説明書」をよくお読みのうえ、正しくお使いください。

technics.jp



Master of Beauty



SELEKT DSM: Edition Hub



Appearance, behavior, sound. Everything is perfect.

SELEKT DSM - EMO Network Player + Preamp

¥3,080,000 (tax included)

SELEKT DSM EO Network Player + Preamp

¥2,530,000 (tax included)

SELEKT DSM EOA Network Player + Integrated Amplifier

¥2,640,000 (tax included)

featuring
 **ORGANIK**
DAC ARCHITECTURE

 NODE

Hear the Revolution.

HYLIXA



www.timelord.co.jp

深遠なる再生芸術の世界へ



Reference Pre Amplifier
UltimaPre2
&
Stereo Power Amplifier
Ultima5



VERTERE™

Reducing engineering to its fundamentals,
to get you even closer to the original recording.

**Stereo Sound
Grand Prix
2022**



SG-1 PKG ¥5,280,000
Record Player & Tonearm set

TAKTSTOCK CO.,LTD.
6-16-15 Saginomiya, Nakano-ku, Tokyo, 165-0032 JAPAN
<https://www.taktstock.co.jp/>



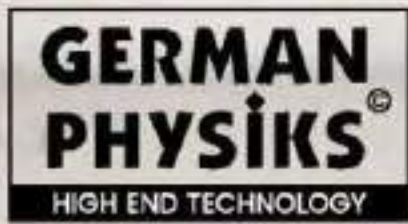

GERMAN PHYSIKS IS BACK!

Since 1992, Has been widely regarded as the manufacturer of the world's most advanced omnidirectional loudspeakers.

HRS-130 ST
(Satin Finish)
¥4,180,000 / pair

HRS-130 HP
(High Polish Finish)
¥4,620,000 / pair

HRS-130 CF
(Carbon Fiber Finish)
¥4,950,000 / pair



TAKT  TOCK

Walk with warm Heart

WELLFLOAT®

CHALLENGE TO ZERO DISTORTION





WELLFLOAT Babel

The Ultimate Insulator

The ultimate model of the Wellfloat series suppresses sound distortion with a 4-layer multi-stage pendulum. Achieves ideal vibration control by supporting the center of gravity of the device.



Dimensions: Diameter 175mm x Height 65mm
Price: 600,000 yen (660,000 yen including tax)



Grand Prix

Gclef Sound Co., Ltd.

1-10-19 Iguchido, Ikeda City, Osaka 563-0023 TEL: 072-762-8730 URL: <https://www.wellfloat.com/> Email: info@wellfloat.com

NEW PIEGA COAX GEN2 SERIES

 SWISS HANDCRAFTED LOUDSPEAKERS SINCE 1986



COAX 811

Black, White: ¥5,390,000/pair (tax included), with bottom plate ¥5,511,000/pair (tax included)

Silver: ¥5,280,000/pair (tax included), with bottom plate ¥5,401,000/pair (tax included)

COAX 611

Black, White: ¥3,025,000/pair (tax included), with bottom plate ¥3,124,000/pair (tax included)

Silver: ¥2,915,000/pair (tax included), with bottom plate ¥3,014,000/pair (tax included)

COAX 411

Black, White: ¥1,650,000/pair (tax included)

Silver: ¥1,540,000/pair (tax included)

COAX CENTER 211

Black, White: ¥1,078,000/piece (tax included)

Silver: ¥968,000/piece (tax included)



•Catalog requests and product inquiries: Furen Coordination/0120-004-884 www.piega.jp

PIEGA

S W I T Z E R L A N D

DYNAUDIO



Stay home,
Stay with music !



(Contour 301 Black finish)

New Contour i



Contour 25i



Contour 20i



Contour 30i



Contour 60i

(Both have Grayoak finish)

**Stereo Sound
Grand Prix
2020**



<Grand Prix Winner>
DYNAUDIO Contour 301

<Authorized import agent>

DYNAUDIO JAPAN Co., Ltd. <http://dynaudio.jp/>

104-0041 | Chuo Ward, Tokyo Shintomi 1-16-12 | Shintomi Annex Building | TEL:03-5542-3545

T.A.D.

Evolution Series



Beautiful innovation. Beautiful space.



SPEAKER SYSTEM
Compact Evolution One
TAD-CE1TX

*TAD-CE1TX was awarded (Stereo Sound Grand Prix 2022).

<http://tad-labs.com>

Eccentricity Detection Stabilizer

ES-001

Eccentricity detection stabilizer



The world's first stabilizer that detects and adjusts the eccentricity of records.

(Patented)

PILIUM

2022 Winter Debut

ALEXANDER Reference PreAmplifier

¥7,000,000-(¥7,700,000/tax included)



HERCULES Monoblock Power Amplifier

¥6,250,000-(¥6,875,000-/tax included/unit)



naspecaudio.com

Naspec Co., Ltd.

〒500-8386 1-4-5 Yabuta Nishi, Gifu City, Gifu Prefecture



0120-932-455



@naspecaudio



@naspec_audio

NASPEC
CORPORATION



audio-technica

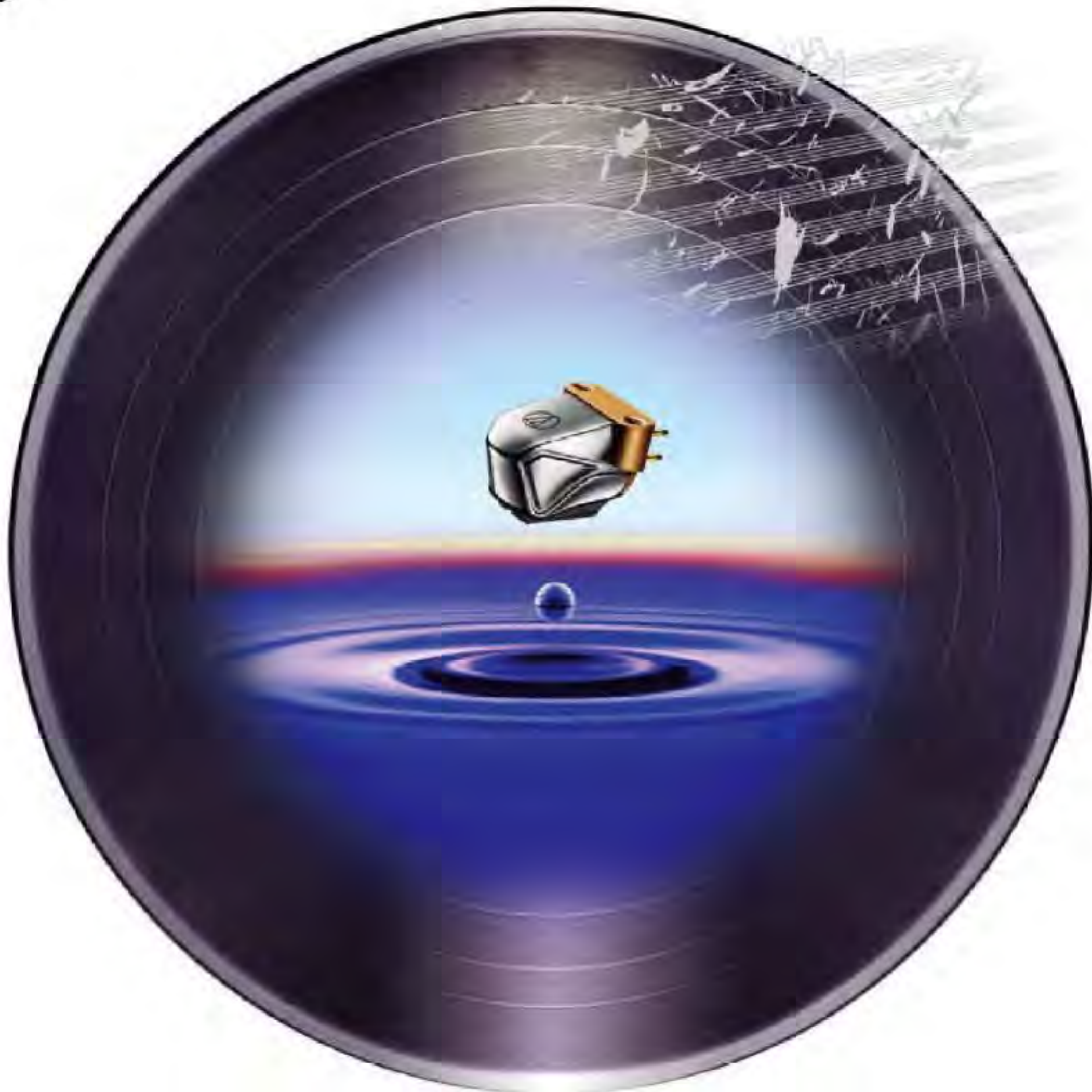

A drop of
abyss

Dual moving coil (MC) stereo cartridge

J AT-ART20 M
¥550,000 (tax included) **MADE IN JAPAN**

new

- The ART series MC cartridge literally leads the cutting edge of analog audio. Introducing a new high-end model filled with the rich flavor that only traditional analog products can provide.
- The ART series can be classified into two types based on the structure of the generating coil. The orthodox iron core type and the air core type with low magnetostriction are available.
- AT-ART20 is the former. But that's not all. While making full use of the energetic advantages of the iron core type, it also brings out the delicacy and vividness of the air core type.



It incorporates the power of musical expression without compromise.

- Improved power generation efficiency by reviewing the magnetic circuit. Light, highly rigid, wide-range vibration system. Or, centering around a titanium housing with a beautiful glossy curved finish, we also offer resonance-free bodies that utilize technology to combine different materials.
- What you hear is the essence of analog sound unleashed by the fusion of carefully selected original technologies. Enjoy the powerful instantaneous response and clear depth of resonance even from the sound of a single drop.

Paradigm®

Paradigm's pinnacle 9H

Advanced, original, supreme technology.

Persona, the super-dreadnought flagship created by Canada's leading speaker brand Paradigm, is on the 9th. The core is a hybrid system with a class D amplifier with a total output of 1400W (700W x 2), and an amazing 3.5-way 6-driver configuration consisting of a tweeter/midrange unit that uses a 99.9% pure Truextent beryllium diaphragm. It achieves high efficiency with a sensitivity of 96dB, and is also compatible with ARCT™ technology, which allows you to obtain the optimal low frequency range according to the listening environment. You can enjoy to your heart's content the overwhelmingly high power, crystal clear sound expressiveness, and the ultimate in music reproduction that can only be experienced with Beryllium, the pinnacle of Paradigm.

ARC
A THEM
ROOM CORRECTION

PERSONA. 9H

6-driver, 3-1/2 Way Hybrid Floorstanding Speakers

7,480,000 yen (tax included) [Pair Standard Color]

8,976,000 yen (tax included) [Pair Custom Color]



**Stereo Sound
Grand Prix
2020**



Product preview information

Would you like to try out Paradigm, Martin Logan, and Platanus products on our reference equipment?

Customers who are considering purchasing the product will be able to listen to their favorite audio source for two hours at a time to thoroughly appreciate its appeal. To apply, please use the homepage or the QR code on the right. [Parking available/If you are coming by car, please let us know at the time of reservation]



Special feature

By genre/price range

527 Best Buy Components

BUY BEST

COMPONENTS '22-23

speaker system	134 models
digital disc player	36 models
digital disc transport	11 models
D/A converter	24 models
digital file player	19 models
preamplifier	47 models
Power Amplifier	66 models
Integrated amplifier	41 models
analog player	25 models
phono cartridge	36 models
phono equalizer amplifier	30 models
Other components	32 models
sound accessories	26 models

Onodera Koji
Fu
Kenji Mayuzumi
Kenji Mayuzumi
Miura Takahito
Tadashi Yamanouchi
Tadashi Yamanouchi

- LS31B
- Speaker System
- DD Player
- DD Transport
- D/A Converter
- Digital File Player
- Preamp
- Power Amp
- Integrated Amp
- AD Player
- Phono Cartridge
- Phono Amp
- Other Component Accessory

Speaker System

speaker system

→ **20**

Less than 10,000 yen

First place

sonus faber
Lumina I
¥108,000(pair)



speaker system

20 → **40**

Less than 10,000 yen

1st

place B&W
706S3 (Gloss Black)
¥334,800(pair)



speaker system

400,000
yen or more



80

Less than 10,000 yen

1st

place

B&W 70553 (Gloss Black)

¥512,000 (pair)



speaker system

80
Less than 10,000 yen



160

Less than 10,000 yen

1st

place B&W

702S3 (Gloss Black)

¥1,036,000 (pair)



speaker system

160-



320

Less than 10,000 yen

sonus fabere
First place **Olympica Nova V**
¥2,100,000 (pair)



speaker system

320 →

More than 10,000 yen

First place

B&W
801 D4 (Gloss Black)
¥4,960,000 (pair)

B&W
705S3 (Gloss Black)
¥512,000 (pair)



Digital Disc

Player Digital Disc Player

→ **30**

Less than 10,000 yen

First place

marantz
SACD 30n
¥298,000



digital disc player

30 → **100**

Less than 10,000 yen

First place

Luxman
D07X
¥750,000



digital disc player

100 →

More than 10,000 yen

First place

Soul Note -
S3 ver.2
¥1,490,000



digital disc player

100 →

More than 10,000 yen

1st

place Accuphase
DP1000

+

DC1000

¥2,600,000 (set)



Digital Disc Transport

digital disc transport

1st

place Accuphase
DP1000

¥1,300,000



First place

Esoteric
Grandioso P1X

¥3,600,000



D/A Converter

D/A converter

→ **70**

Less than 10,000 yen

1st

place Soul Note

D2

¥660,000



D/A converter

70 →

More than 10,000 yen

1st

place Soul Note

D3

¥1,680,000



Digital File Player



digital file player

First place

soul note

Zero Link Ultimate System

¥3,210,000 (set)

Preamp

preamplifier

→ **100**

Less than 10,000 yen

First place

Uegi U-
Bros 280R
¥980,000



preamplifier

100 →

More than 10,000 yen

1st

place Accuphase
C3900
¥2,000,000



Power Amp

Power Amplifier

→ **100**

Less than 10,000 yen

First place

Esoteric
S05 (Silver)
¥900,000



Power Amplifier

1-2 million
yen or more
Less than 10,000 yen

1st
place Accuphase
P7500
¥1,350,000



Power Amplifier

200 →
More than 10,000 yen

Soul Note
1st place M3
¥3,000,000 (pair)



Integrated Amp

Integrated amplifier

→ 30
Less than 10,000 yen

First place
Marantz
Model 30
¥298,000



Integrated amplifier

300,000
yen or more

80

Less than 10,000 yen

First place

accuphase
E4000
¥630,000



Integrated amplifier

80



More than 10,000 yen

First place

accuphase
E5000
¥950,000



AD Player

analog player

First place

Luxman
PD191A
¥900,000



Phono Cartridge

phono cartridge

First place **DS Audio DS-W3 Cartridge**

¥450,000



Phono Amp

phono equalizer amplifier

First place
Accuphase C47
¥650,000



First place
Japanese cedar
U•Bros 220R
¥650,000



Other Component

Other components

First place
DELA N1-538-J
¥1,200,000



Sound Accessory

Sound Accessory



First place

AGS
Hybrid ANKH II (corner type)
¥340,000~¥470,000

First place

claudio
CLN-LP200T
¥1,130,000



First place

Hanlu

Mera Professional RB
¥740,000



best buy components

Editorial department

About the selection method

•Products subject to selection

For this year's Best Buy Components, audio equipment that satisfies any one of the conditions ① or ② listed on the left will be selected.

(Fig. ①/Products)

that were newly released between December 2021 and December 2022, and were available for preview as a finished product or final prototype by the end of October 2022.

②Products that were selected as best buy components

in issue 221 of this magazine (released in December 2021) and are still on sale as of the end of December 2022 (including products only in distribution stock).

•Selection committee

There are five audio critics serving as selection committee members: Hiroji Onodera, Nobuyuki Fu, Kenji Mayuzumi, Takahito Miura, and Tadashi Yamanouchi (first time selection). As a general rule, Mr. Onodera does not consider products with a list price of more than 8 million yen (excluding tax) in all product categories.

•Selection method

Details of the selection method are shown in the table on the left, and the scoring rules for each product category have remained largely unchanged since last year.

Each selection committee selects the best buy

components within the range of the total number of selected models set by the editorial department of this magazine for each product category, and then selects the best buy components (product genres have price range classifications), 3 Points (for one model only), 2 points (for up to 3 models), and 1 point (for all remaining models). In other words, the product with 3 points in each genre/price range is the best one for the selection committee, and the product with 2 points is the second best. In addition, for the three categories of "Digital File Player", "Other Components", and "Sound Accessories", the score is 3 points, 2 points, 1 point, 3 points.

It is up to the selection committee to decide whether or not to grade each stage. It is left to the voluntary judgment of the members.

•Product genre and price range classification

Product genres are divided into types, the same as last year. The product categories classified into price ranges are the same as last year, with a total of six categories: "speaker systems," "digital disc players," "D/A converters," "bria amplifiers," "power amplifiers," and "integrated amplifiers." In addition, price ranges are divided based on tax-excluded prices, as in the past, and prices are, in principle, tax-excluded.

remarks	page
	184
	186
	188
	190
	194
	196
	199
	200
	202
	204
	206
If it is less than 700,000 yen, you can select only one model.	207
	209
	210
	212
	215
	216
	218
	221
	222
	224
Nisemuku fu abanet from wind	226
Mr. Fu Xinxing is Bing Qin	228
Mr. Fu Renshin is the king	230
	233
	234

Best Buy Component Selection Method

Product genre	Price range classification	Number of selected models	Scoring rules
speaker system	Less than 200,000 yen 200,000 yen or more but less than 400,000 yen 400,000 yen or more but less than 800,000 yen 800,000 yen or more but less than 1.6 million yen 1.6 million yen or more but less than 3.2 million yen 3.2 million yen or more	Total number of models: 18 or more and less than 60 models / 3 or more models in each price range	3 items in each price range = 1 model, 2 items = within 3 models. Every single item left
digital disc player	Less than 300,000 yen 300,000 yen or more but less than 1 million yen 1 million yen or more	Total number of models: 9 to 30 models, winter price range 3 or more models	3 items in each price range = 2 items per model - within 3 models / 1 item = all remaining
digital disc transport		Total number of 3 or more models and 5 or less models	3 points = 1 model / 2 points = 3 or more models / 1 point = all remaining
D/A converter	Less than 700,000 yen 700,000 yen or more	Total number of 6 models or more, 15 models or more, each price is 3 or more models	3 items in each price range - 1 model / 2-3 models or less / 1 item = all remaining
digital file player		More than 10 models in total	3 points - 1 model (optional without) / 2 points - 3 models or less (optional without) *1 point = all remaining
preamplifier	Less than 1 million yen 1 million yen or more	Total number of 6 models or more and less than 25 models, 3 or more models for each grade level	3 items in each price range = 2 items for 1 model = 3 models or less, 1 item and all remaining items
Power Amplifier	Less than 1 million yen 1 million yen or more but less than 2 million yen 2 million yen or more	A total of 9 models or more and 35 models or more, 3 or more models for each rank band	3 items in each price range = 2 items per model = 1 item within 3 models, all remaining items
Integrated amplifier	Less than 300,000 yen 300,000 yen or more but less than 800,000 yen 800,000 yen or more	A total of 9 or more models and less than 25 models, 3 or more machines in each rank category	3 items in each price range = 1 model / 2 items = 1 item within 3 models and all remaining items
analog player		Total number of models: 3 or more and 15 or less	3 points - 1 model, 2 points - 3 models or more 1 point 1 all the rest
phono cartridge		Total number of 3 or more models and 18 models or less	3 points = 1 model 2 points = 3 or more models 1 point = all the rest
phono equalizer amplifier		Total number of 3 or more models and 15 or more models	3 points = 1 model 2 points - 1 point within 3 models = all the rest
Other components		Total number of 15 models or more	3 points = 1 model (None is also possible) // 2 points = Within 3 models (None is also **) / 1 point = All remaining
sound accessories		Within 10 models in total	3 points - 1 model (optional without) / 2 points - 3 models Within (none or ding) / 1 point = all remaining

1st place Sonus Faber Lumina | ¥108,000 (pair)



- A small speaker that can be placed anywhere and looks good no matter where it is placed. Sonus Faber's products clearly demonstrated that they are skilled at making not only handmade craft-level products, but also mass-produced products. Although the price has increased by about 10,000 yen for a pair, it is a speaker that will surprise you with this sound at this price, and the high level of satisfaction for the price is undeniable. (fuu)
- The bright and glossy tone brings out a lively expression, giving you a charm that you can't get anywhere else. Although he has a strong individuality, there are few instruments or genres that he is not good at, and not only the vocals and stringed instruments that sing the melody freely, but also the countermelody and rhythm have a bouncy and dynamic feel, and their ability to revitalize the performance is extraordinary. Both the sound and the appearance have a quality that makes it hard to believe that it is a low-priced model. (Yamanouchi)

3rd place Technics SB-C600 ¥100,000 (pair)



- Technics categorizes its products into classes, but the hierarchy of sound quality shouldn't have anything to do with which class they're placed in. This unit is a compact model equipped with a coaxial unit consisting of a 15cm woofer and a 2.5cm tweeter developed by Dokuraku. Hideki Haku is quick to respond, has high linearity, and has a large amount of information. Even though it is an entry class, it is an authentic model. (Onodera)
- As a result of newly developing a coaxial unit with a slightly smaller diameter than the higher-end model, Ichida it became even more attractive. Best of all, it has a quick reaction. The presentation of sound field information is also correct.
- The sound image is three-dimensional and sharp. No unpleasant taste. It has a clean, pure sound and a smooth texture. Low sound considering its small size. It has a lot of volume, and the glossy sound of the vocals is also pleasant. (Mayuzumi)

2nd place B&W 60652 Anniversary Edition ¥125,000 (pair)



- Equipped with a continuum cone similar to that of higher-end models for better sound visibility. It has excellent performance and quietness. The metal dome of this unit has good extension of the high frequency range. It's good. The results of research and development by the company's R&D center are reflected throughout, and it also features a well-balanced energy balance. When installing this unit, we recommend that you use the genuine stand, which is said to be excellent in terms of sound quality. (Miura)
- When you want to maintain a good line of sight for small speakers but don't want the support for bass instruments to become thin, this unit's good balance shines among the 600 series. With this minor change, we have upgraded the parts of the crossover circuit such as the capacitor, so you can now enjoy the clearer tone of the Continuum Cone even more than the base model. (Yamanouchi)

1st place Piega ACE 30 ¥180,000 (pair)



•If you are a fan of compact, high-performance products, you may be charmed just by looking at the ACE30. Bass instruments are thicker than you might imagine from their appearance, and the center of gravity for energy balance is surprisingly low. It seems like a 12cm woofer.

The low-pitched sound is a result of the enclosure, which prevents energy from being lost due to unnecessary vibrations. (Yamanouchi)

Score 5

Three nights Yamanouchi

3rd place Quadrale Signum 20 ¥115,000 (Bear)



•Quadral speakers used to have a strong accent sound. Although it was unique, the Signum is like a reborn Quadral product. I think the strong accent has disappeared and the sound has become more international. Previously, sales were mainly within Germany, but now they are exported to other countries. He's a cheeky little guy with a cheerful voice. (Fu) •In recent years, Quadral has broken away from the distinctive, local sound of the past. All models are neutral and have a high level of musicality, giving you a sense of satisfaction that far exceeds the price. This unit also has a loud sound that you can't believe its size. Even if the distance between the cars is wide, the sound field does not get thinner. The volume of the bass too is sufficient and is capable of accurately reproducing the pitch changes of the bass. (Yamanouchi)

Score 6

Onodera

7th place Quadrale Signum 70 ¥198,000 (Hair)



•It not only achieves an outstandingly high C/P, but also inherits the unique features cultivated by the company's high-end machines. Not only does it have a reasonable price tag as a floor-standing machine, but it also has a clear rendering power from low to high frequencies. The ring-dome shaped tweeter has a sparkling tone. (Ichiura)

Score 3

Mitsawa

Yamanouchi

3rd place JBL 4309 ¥180,000 (pair)



•The diameter of the woofer is 16.5 cm, so it's probably not that small these days, but it's a cute size, and the ring radiator + horn handles the high frequencies, giving it the lively sound typical of JBL. That's the biggest attraction. The connection between the horn and woofer is perfect, allowing you to enjoy a sharp, fresh, and youthful sound. (Onodera) •When I first heard it, I couldn't help but whisper, "You'll do it!" sense of volume. The sound is so loud that you don't feel the size, and it's typical of JBL, positive. The lively sound is fun. Special type that utilizes advanced diffusion control technology. The shaped horn provides a vast service area and clear sound image localization. OK. You can clearly hear the positions of all the instruments on the strata. (Miyata)

Score 6

Miyata

8th

JBL	L52 Classic	¥100,000	小野寺 ★
Eppens	A100 HD Monitor OPD pair	¥110,000 after	熊 ★
clinton	KX0.5 II	¥195,000	Miura ★★

11th place

JBL	Stage A130	¥28,000 pair	小野寺 ★
B&W	60752 Anniversary Edition	¥100,000 bear	小野寺 ★
Monitor Gardens	Silver 50-7G	¥145,000; Pairama Ward ★	
Dynaudio	Emit 20	¥170,000 pair	熊 ★
falcon lab	Model D102	¥190,000/pair	熊 ★
Fostex	GX100BJ	¥188,000 pair	Miura ★
Fine Audio	F500	¥198,000 pair	小野寺 ★

1st place B&W 70653 (Gloss Black) ¥334,800 (Bare)



•The slightly smaller 707S3 is nice, but the 130mm diameter is a little small if you want to cover orchestras and big bands. Therefore, I prefer this unit, which has the same excellent sound quality. The mid-low range of the 165mm aperture has both volume and texture, and the sound is smoothly connected to the high range with good extension up to the high end. It's a best buy machine that also features a natural sound." (Miura)

•It's true that the 705S3 is more appealing when it comes to the evolution to Series 3, but you can definitely hear the evolution of the 706S3 with its built-in tweeter. In particular, it is easy to understand the benefits brought about by the change in cabinet shape, which introduced a curved baffle and narrowed the width, and the ability to develop a three-dimensional sound image that makes the shape of the instrument visible is excellent. The depth of the stage is deep, and the precision of perspective depiction is improved. (Yamanouchi)



3rd place B&W 70753 (Gloss Black) ¥267,000 (Hair)



•B&W's 700 series has evolved from S2 to S3. Since the price of the S2 remained unchanged for the five years it was on sale, the price of the S3 has increased approximately 1.5 times, but it is still a bargain model with a volume effect. This machine is the youngest brother of the 700S3. A 2-way speaker based on a woofer that uses a continuum cone with minimal sound quality. Clean and beautiful sound without any extraneous sound. (fuu)

•The 700S3 series is a masterpiece that utilizes the development results of the 800D4 series. However, the 707S3 is especially attractive due to its compact size and affordable price. Target. It's sharp, and even if the sansho pepper is small, you'll be captivated by the sound it makes. Despite its small size the low-frequency reproduction ability is high, and you can clearly hear the changes in the bass's expression. I am also impressed by how accurately it captures the sense of scale and weight of the drum. (do)

2nd place Sonus Faber Lumina III ¥270,000 (pair)



•"Lumina", the entry line of Italy's Sonus Faber, is a masterpiece series. The compact Lumina I is great, but the tall boy floor type Lumina Mountain is a wonderful model that has a lot more room and allows you to play music with fun and sincerity. It has good sound separation and has the ability to make music penetrate every corner of a fairly large space. (Onodera)

•I'm always impressed by Sonus Faber's new products, but Lumina surprised me not only with its sound, but also with its price. Its appeal has not diminished over time, and it received the highest score this year as well. As it is a 3-way floor-type instrument, the sense of scale of the orchestral pieces is overwhelming. The bass instruments have a wonderful sense of reality and the sound is powerful. With vocal songs, it's as if the singer is standing right in front of you. (Mayuzumi)

4th Audel U-Basik 5/8 (Walnut) ¥390,000(Pair:



•Italian o
Many audio equipment have elaborate designs, and Audel is one such brand. However, I thought that the company's previous speakers had focused on design and mechanism, but after listening to this one, I changed my mind. fire

Onodera ★★
Mayuzumi ★
Yamanouchi ★
Score 5

The sound is very appealing, with just the right balance and high-quality textures, so to speak, that warms your heart. (Onodera)

4th place Quadrale Signum 90 ¥250,000 (pair)



•Signum is fu
The lower type gives the impression of much improved quality and a more spacious sound. Furthermore, the "90" has a noticeable improvement in the sense of scale, and considering the price difference with the "70," it is a great value. Neutral tone unique to the new quadral,

Ono ★★
Fu ★
Miyazaki ★★
Miyata ★
Score

The sound is full of dynamism, and the overtones of the bass come out. (Mayuzumi)

6th place Elak Vela BS403 ¥360,000 (pair)



•This bookshelf model of the Vela series has succeeded in giving a strong impression of a generational shift, with the cabinet's shape being reborn as elegant and dynamic, and the sound also becoming more agile. Four years have passed since its release, but it still has a fresh tone and flexibility.

Mikawa ★★
Yamanouchi ★★
Score

His ability to sing melodies has never faded. First purchase | Recommended as an Elac product. (Yamanouchi) 4

6th place Elak Solano BS283 ¥270,000 (pair)



•A product that was introduced last year and offers great performance, representing the compact speakers made by Germany's Elac. The unique JET unit that handles high frequencies has been repeatedly improved to become even more supple and flexible, and the woofer also features JET's high speed and high energy.

Small field ★★
Fu ★
Score

Good sound that is well balanced with the score. High-quality, mature texture that sounds fresh. (Onodera)

No. JBL L82 Classic ¥270,000 (pair)



•"Classic"
Although he calls himself The sound is modern JBL typical peaker So, the sound field feeling is The demonstrations are excellent 20cm caliber woofer I don't think so Rich sense of scale The sound of jazz Good at playback I'm good at it, inside But the vocals How glossy attractive. rhythm

Mayuzumi ★★
Onodera ★★
Score

The sensibility is also impressive, and as you listen to all the sounds coming alive, your body begins to move naturally. (Mayuzumi)

6th place Piega ACE 50 ¥380,000 (pair)



•Aluminum new long extrusion cut the wood into short pieces and small ACE 30, approximately 5 times When cut to the length of ACE 50 Flo earth standing type enclosure become pure. rationality A typical structure. AMT To the tweeter with a sense of openness sound. It's a thin stick. 2 eel machines

Fu ★
Miyazaki ★
Yamanouchi ★
Score

In between, a soundstage appears, like a wide screen of music, and a miniature sound image unfolds. (fuu)

BEST BUY COMPONENTS

speaker system

Less than

400,000-800,000 yen

9th place Dali Oberon 9 ¥330,000 (pair)



• There are only a few full-fledged floor-type models in this price range, and the 3-way 4-driver Oberon 9 is a valuable asset. Since it has a dual 23cm woofer configuration, care must be taken to ensure that the bass does not interfere with the midrange and high frequencies, but Dali created a midrange chamber. We are trying to solve this problem by making it independent. The result is that her vocal range is not cloudy and she sings freely. (Yamanouchi)

Score: ★★★★★

9th place Krypton KX3SX ¥398,000 (pair)



• Due to closed type This is the latest and most complete product of the company's best-selling "KX3" series, which is particular about clear bass. Because of the quality of the sound, we installed alnico magnets in both drivers, and used Hakusha internal wiring to improve the sound quality. Kurt Muller shake configurations. The friendly sound made by pulp corn is also attractive. (Ichiura) 3

Score: ★★★★★

1st place B&W 70553 (Gloss Black) ¥512,000 (Pair)



Score: ★★★★★

• Since the 700 series has become the S3 version, it has become closer to the 800D4 series. The tweeter tube mounted on the top plate (tweeter on top) is slightly shorter than the 800, and the only difference is that the diaphragm is made of carbon-deposited aluminum rather than diamond. The woofer fin is adjusted to fit the thicker baffle due to the curve. Ram has been strengthened. The connection and spread of sound is really smooth. (fuu)

• The difference from 706S3 is not only the tweeter-on-top structure, but also the bass reflex. The shape and tuning of the output are also different. Three-dimensional modeling and front and back of the sound image of a solo instrument. The depth of the lingering sound that spreads from side to side is better than this, and it is the basis of bass instruments. You should be able to hear the openness and ease of the sound. The difference with 805 is the previous generation. It has clearly shrunk compared to. (Yamanouchi)

12th place	JBL 4305P	¥200,000	★★★★★
	Pharmin Lab Model D103	¥300,000 tax included★	★★★★★
	Fine Audio F500SP (Pier/Gloss Black)	¥310,000 Pair	★★★★★
15th place	Sonetto I	¥208,000: Pair	★★★★★
	Krypton KX1.5	¥280,000	★★★★★
	Sonetto II	¥298,000: Pair	★★★★★
	Balladaim Premier 800F	¥320,000	★★★★★
	Dynaudio Emit 50	¥350,000 pair	★★★★★
	Monitor Audio Silver 300-7G	¥390,000 pair	★★★★★

4 Harves HL-P3ESR XD ¥480,000 (pair)



Onodera ★★
Futoshiki ★
Mikawa Yamanouchi ★★
Two stars

Score 6 |

●Compact 7 and
If the price range was different, I'd give it the highest score, but its capabilities are so strong that I would give it the highest score. If we were to emphasize the differences between the two, would it be possible to say that the P3 has a more modern sound? Not only is it highly transparent, but it also has a pure sound with no unpleasant tastes. Loud re-cow even

If you don't want it, it will give you maximum musical satisfaction. The sound of a piano's strong keystrokes is something that is beyond imagination. (Mayuzumi)

2nd place Harves HL Compact7 ES3 XD ¥680,000 (pair)



Small field ★★
Futoshiki ★★
Mikawa Yamanouchi ★★
score 9

●I have long praised Harbeth's Compact 7ES3 as the best of the best buys, but this model has been improved in detail to achieve even higher quality. Although the price has gone up quite a bit, it's still one of the best. The sound, which is enriched by the balance between the inside and the body, is beginning to stand out among modern high-end machines and is extremely attractive. (Onodera)

●Harbeth is unique, and this sound is precious. The product's appearance, which is different from that of a product at the cutting edge of audio technology, seems to convey the developer's message, "What more do you need to listen to music?" He is a talented player who does not emit any irritating sounds and maintains a comfortable listening experience while being able to hear all the sounds emitted as musical expressions. (Mayuzumi)

Technics SB-G90M2 ¥596,000 (hair/tax included)



Onodera ★★
Mikawa Yamanouchi ★★
score 5

●An equalizer is installed in front of the tweeter dome to smooth out the connection and spread of sound. The theme is Linear Eyes based on Technics' design philosophy. A crisp, focused sound image protrudes throughout the entire band. the range, and a clear sound.

Score: A neat sound with no harsh sounds throughout the range, and a clear sound. It's a low, calm sound, but it's true.

3rd place Vivid Audio KAYA S12 ¥610,000 (pair)



Futoshiki ★★
Mikawa Yamanouchi ★★
score 7

●Vivid Audio has a high-end series called GIYA, but the KAYA series includes relatively compact systems aimed at greater ease of use. This machine in particular is a cute little machine mounted on a unique stand. However, the sound is authentic and the texture description is of the highest quality. In addition, the active and rich expressiveness that vividly conveys the dynamism of the music is truly enjoyable. (Onodera)

● This speaker system is packed with all of the company's high-quality sound technologies and produces a stylish and wonderful sound. Anyone who listens to the sound will be overwhelmed by the smooth sound and rich sound field. The range is wide in terms of hearing. Omni-absorber chi inside sarb structure seems to contribute greatly to the clear bass range, so it took a long time to develop. This is a product that you will want to listen to in combination with a dedicated stand (sold separately). (Miura)

5th place Fine Audio F700 ¥710,000 (pair)



Onodera ★★
Futoshiki ★★
Mikawa Yamanouchi ★★
score 5

●It was founded by members who were independent from Tannoy, and the "Fine" in the company name comes from the name of the lake, not Fine. This machine is a small model equipped with a 15 cm diameter coaxial driver. The day I saw it, it looked just like Tannoy, but the details were fine

Score Full of unique designs. For example, a scalpel is inserted into the edge of the cone to create a soundless bass reflex. audio.

7th place B&W 70453 (Gloss Black) ¥604,000 (pair)



●Continua
The midrange of the music cone has biomimetic suspension, resulting in sensitivity and a large number of sounds. The midrange and high frequencies are decoupled to ensure clarity even when the volume is turned up. Aerofile technology woo

The fur also achieves a clear low frequency range, and the sound quality that is consistent and consistent across all-sound parameters is wonderfully appealing. (Miura)

Miura ★★★★★
Score 4

7th place Krypton KX5PX ¥498,000 (pair)



●The honest, high-quality bass that can only be achieved with a closed-back type is the biggest reason to choose this unit, but with the generation change from P to PX^α, not only spatial separation but also temporal dynamic resolution has improved. I would like you to pay attention to this as well. Krypton's speakers have the best bass. (Yamanouchi)

Although it has plenty of volume, it also achieved the highest level of responsiveness, pa

4 Wiring connection is recommended. (Yamanouchi)

Miura ★★★★★
Yamanouchi ★★★★★
Score 4

11th place

オーディオテクニカ	Phantom I 108dB Gold ¥449,000 tax included	小塚 ★★
ヤマハ	14DS ¥420,000	Miura ★★
ビエラ	Premium 301 ¥420,000(7)	小塚 ★ 傅 ★
ザリオリ	Nobile with Stand ¥600,000	Fu ★★
focal	Aria K2 936 Limited Edition ¥680,000 (pair)	Yamanouchi ★★
Sonus Faberre	Sonetto V ¥695,000~7	Fuyamanouchi ★
paradigm	Founder 100F ¥700,000	Den Mayu ★
Fine Mardio	F501SP ¥60,000 yen~7	傅 ★ Miura ★

19th place

ソニー	SA-Z1 ¥780,000a	★
-----	-----------------	---

9th place Elac Solano FS287 ¥520,000 (pair)



●Inside Elac, important core 200 series especially musical Good balance What stands out is Solano floor 2021 as a type appeared in the year It's FS287, bass shrine fluctuation due to the support of In addition to the fact that there is no Rhythm movement if the growth becomes slow Dynamic resolution

The feel has definitely improved from the previous generation. Furthermore, I also like the high brightness of the mid- the natural tone that does not become flamboyant (Yamanouchi) high range and

Fu ★★★★★
Yamanouchi ★★★★★
Score 3

9th place Sonus Faperre Minima Amator II ¥560,000 (pair)



●Minima Amato Rule (1993), Minima Vin Teage (2008) The results of Involvement, further reach heights bibal model is this machine. black wrapped in leather Buff before and after soldering Ru and Mukuwal Constructed of nut material: Enclosure "A made it possible

The sound is precise and expresses the energy of the orchestra in just the right amount. I am captivated by the luster of her voice. (Mayuzumi)

Fu ★★★★★
Yamanouchi ★★★★★
Score 3



BB
speaker system
80-160
Less than 10,000 yen

2nd place B&W 805D4 (Gloss Black) ¥1,020,000 (pair)



Onodera ★★
Miyazumi ★★
Yamanouchi ★★
Score 8

•The advantage of small speakers is that the small enclosure is durable, the sound sources are concentrated, and there are few reflective surfaces, so the sound is exposed. This machine satisfies these requirements. The delicacy of the resonance, quietness of the sound stage, and large amount of information are unique to a diamond tweeter, and it is a wonderful 2-way combination with a cone-based woofer that has extremely minimal sound distortion. (fuu)

•It received high praise almost immediately after its release, but when I listened to it again, I was impressed by Kiki's unfathomable ability. Among them, I particularly value their high linearity in the soft range, and their ability to precisely capture facial expressions that tend to be warm and subtle gradations is second to none. By reviewing the cabinet shape, spatial reproduction power has also reached the highest level ever. (Yamanouchi)

Place B&W 70253 (Gloss Black) ¥1,036,000 (pair)



Fu Onodera ★★
Miyazumi ★★
Miura ★★
Yamanouchi ★★
Score 12

•The 700 series has been improved to S3 and its appeal has increased all at once. Among them, the evolution of 70253 is astonishing. Although there is a considerable difference in quality compared to other models in the series, the price difference with lower-end models is also small, making it an overwhelming best buy model. The effect of the "tweeter on top" is tremendous, and I am amazed at the outstanding expansion of the sound field, and especially the deep expression of "Audio controls the mind". (Heat) •The smooth expansion of the sound field created by the improved tweeter-on-top is a perfect match for the new mid-range driver, which features a biomimetic suspension that provides a rich number of sounds and delicate expression. This model is the only one in the 700S3 series that has a bass reflex port on the bottom, and is characterized by a deeper bass range. It is a product that has acquired a sense of grand scale. (Miura)

4th place Franco Serbrin Accordo ¥1,300,000 (pair)



Onodera stop ★★
Miyazumi ★★
Yamanouchi ★★
score 8

•Aspirations for form and sound
The direction is this much match
There are other speakers I have no idea.
Theory alone is not enough
The only thing that can't be broken is
It's the essence of music
Then, Accorda
The essence of very close located in
Ru. 10 since release over a year old
How do I feel contribute to be valuable
I don't think it will ever fade. The richness of expression is closer to that of a musical instrument than a speaker. (Yamanouchi)

2nd place Piega Coax 411 (black) ¥1,500,000 (pair)



Onodera ★★
Miyazumi ★★
Miura ★★
Yamanouchi ★★
score 8

•When you listen to this unit, you can realize that Piega is good at small speakers. It is a compact 3-way model with an aluminum enclosure that is approximately 5 cm taller than the previous model 311, making it more durable, and the company's proprietary coaxial driver with a strengthened frame and magnetic circuit. The ribbon driver is dominant, creating a splendid sound that combines high transparency with a rich sense of power. (den)

•The most distinctive feature of this series is the coaxial ribbon unit, but when listening to I have never noticed the sound of a bong. All bands are seamlessly connected and the texture is The tones are beautifully unified. 411 has a voluminous touch that doesn't make you conscious of its size. The bass of the preamp is pleasant, and the sound of the cymbals is very realistic. high purity The height is also impressive, and I fall in love with it and think, "That's a great sound." (Miyazumi)

6th place B&W 70353 (Gloss Black) ¥900,000 (pair)



•Height approx. 110cm
Good size to fit a small inch. The tweeter-on-top design of the same company's speakers, in which the tweeter is mounted on the top plate, is clearly effective in widening the sound and creating a sense of atmosphere. With the 700S3, the 703 also has a tweeter on top.

Score 4

He is good at expressing acoustic instruments, and the sound is clear and beautiful, as the atmosphere of the performance venue is floating. (fuu)

5th place TAD TAD-E2 ¥1,580,000 (pair)



•I think one of the reasons why TAD has gained so much support is that there is no deviation in design philosophy. Get a concrete idea of the sound you're looking for, and steadily move closer to that ideal while examining techniques. The author has that impression about this brand, but E2 is another important product that brings us one step closer to that ideal. Localization accuracy is at an unprecedented level for a floor-type camera. (Yamanouchi)

Score 6

6th place Magico A1 ¥1,200,000 (pair)



•The company's A series
This compact model is characterized by the bass sound characteristic of a sealed model and the treble range produced by a pleasantly extended beryllium diaphragm. Robust metal enclosure provides unambiguous sound and graphene nanotech with visible carbon fiber woven fabric.

Score: The woofer has a large diaphragm, making it easy to hear rhythmic beats. High Definition
4 A product whose most appealing feature is detailed visual sound. (Miura)

6th place Yamaha NS3000 ¥1,000,000 (pair)



•Yamaha speed
The car system is packed with monologue techniques, and each model shows the results of meticulous research. This device is a bookshelf type that inherits the technology of the flagship model NS5000, and uses a diaphragm made of the chemical fiber Zylon throughout the entire area.

Scores: It is characterized by the uniformity of the old colors. (Ageni Fusawa)
The beautiful, clear and exhilarating sound is appealing. (Onodera)

9th place KISO Acoustic HB-N1 ¥880,000 (pair)



•Wooden enclosure
- The Sound of Jua
By taking advantage of as if in front of my eyes
Live music unfolds
Are you feeling well?
feeling like
will you give it to me
is the company's speaker
The charm of cars, heat
audiophile
file owner
The final tune is heard.
-ning
This machine is a small machine.

Score 3
It plays music with an unexpectedly cheerful quality. Who does the manufacturing Takamine Musical Instruments Manufacturing Co., Ltd. is world-famous for its guitars. (Ura)

9th place Sonus Faperre Olympica Nova I ¥850,000 (pair)



•Sonus Fabe
Lute-shaped
Enkuro called
-Jua is now
and the mainstream water
droplet enclosure
It is the prototype of Jua.
Continuous curvature
to change to
increases rigidity
resonates at the same time as
can be dispersed,
Kill two birds with one stone
That's it. Olympica
Nova series

Score 3
What we use is the "Enhanced Lyra Sinippe," which is a major evolution of that technology. It is a small giant with a beautiful finish. (Shin)

9th place **Paradigm Founder 120H ¥1,100,000 (pair)**



•Listening
 A major feature is that it is equipped with a low-frequency power amplifier that has a DSP compensation function that can avoid the negative effects even if the acoustic characteristics of the system are peculiar. As a result, there is no turbidity in the low range, and the sound is highly transparent across the entire range. sound

Onodera ★
 御 ★
 城 ★
 Score 3

The expansion and depth of the space are also clearly expressed. When I listen to this sound, the words "unwavering stability" come to mind. (Mayuzumi)

9th place **No. Harbeth Super HL5 Plus XD ¥900,000 (pair)**



•Although it is a 3-way device, it is actually a 2-way + super tweeter configuration. Compared to conventional harvesters, the clarity of sound and fine resolution are greatly improved. It has a natural tone with no noticeable quirks, and is characterized by an indescribably pleasant sound. Extremely high quality actively but has an

御 ★
 城 ★
 Miura ★
 score 3

It is also a sound. I like the sound, which expresses the music elegantly without being pushy. It's a profound sound. (Mayuzumi)

9th place **Sonus Faperre Electa Amator III ¥1,380,000 (pair)**



•It has already been three years since I went to listen to the latest generation, which was released 32 years after the first generation, and was curious to see how much of the musicality of the original had been inherited. The impression I got then remains the same, especially the dynamic facial expressions that are the highlight of the performance.

Onodera ★
 御 ★
 Yamanouchi ★
 score 3

Abundance is truly unique. (Yamanouchi) The direction of evolution is also accurate, such as the a precise rhythm without muddiness. bass that carves

9th place **Elak Concentro S 503 ¥1,300,000 (pair)**



•Erak's new series, conti First time in Entro Books that appeared Elf-type Sith Tem. The company is big I have cultivated it with great care. JET unit, Here, the midrange In the center of the knit coax placed 18 centi woofer Authentic along with I raised it as a 3-way

Onodera ★
 御 ★
 score 3

system scoring system. A high-quality speaker that depicts a grand old place in great detail and has excellent sound quality and texture. (Onodera)

16th place

4349	¥900,000	御 ★
JBL place Dibusadio Contour 301	¥1,250,000	御 ★ Ura ★
Sonus Vaper Olympica Nova III ¥1,550,000 Fuuyamanouchi ★		

19th place

Dynaudio	Contour 20i	¥800,000	A special feature ★
Erakku	Vela FS408	¥900,000 pa	御 ★
krypton	KX1000P	¥950,000:Pair	Sanmo ★
Sochis Fapen	Sonetto VII	¥950,000 pair	御 ★
gothic	Vela FS409	¥1,050,000 pair	御 ★
御	Premium 701	¥1,080,000 pair	御 ★
Audiomacito	CRMX	¥1,180,000	御 ★
Sony	SS-AR2	¥1,200,000	Baa Miura ★
T.A.D.	TAD-ME1	¥1,280,000 Pair	Yamatate Ward ★
KISO Acoustic	HB1	¥1,300,000:	Bear Miura ★
御	Epicon 6	¥1,320,000	御 ★

9th place **Paradigm Persona B ¥1,500,000 (pair)**



•In front of the woofer surface, geometric pattern board with holes in it. Enjoy the individual without Have it ready in front of you. I received it and listened to it. danging sound That's what I heard There was no. lku The academic pattern is just a date Not the sound Expansion and balance are coordinating with Nada. The company is a force Nada's big speaker

Onodera ★
 御 ★
 Miura ★
 score 3

car manufacturer. In addition to having measurement equipment in place for research and development, we also spend long hours conducting hearing tests. (fuu)

1st place Sonus Faber Olympica Nova V ¥2,100,000 (pair)



- The enclosure is made by stacking 8 thin plates and molding bent wood into the shape of a lute, an ancient musical instrument. It is strong, allows the occlusions to be dispersed, and is beautiful to say the least. The floor-standing model has an elongated metal bass reflex opening at the rear, which prevents air noise and internal noise from escaping. An exquisite balance of volume and speed in the low range, with warm and glossy mid-to-high tones. (fuu)
- Even before I hear the sound, I can't help but sigh at the beauty of her appearance. Although it is an improved model of the old Olympica, it is a masterpiece that is extremely close to the homage tradition of higher-end models, and can even be said to surpass it in some areas. Although the sound is at the cutting edge of modern audio, the tactile feel of the sound is incredibly gentle and captivates the listener, over stringed instruments
- The tone flows beautifully and you will be fascinated by the deep bass. (Mayuzumi)

BEST BUY COMPONENTS
speaker system
Less than 1.6-3.2 million yen

3rd place B&W 804D4 (Gloss Black) ¥1,820,000 (pair)



- I wrote in issue 221 that "If you want to experience a thrilling world full of surprises, the 804D4 is the best," and that opinion has not changed. He is a challenging speaker. It has the ability to respond quickly to changes in settings, and with its unusually good S/N sensitivity, a "world of silence" unfolds right before your eyes. It is also amazing how accurately it depicts the musicians' playing techniques. (Mayuzumi)
- Similar to 805D4, technology common to higher-end models such as reverse wrap cabinet
- It is a deep fish that we have made a big leap forward from the previous generation by introducing this design.
- It has taste. A group of three-dimensional instruments unfolds in a clear sound field.
- The sight is spectacular. Good quality and low center of gravity even in rooms with small air volume
- I especially recommend it to music fans who are looking for band balance. (Yamanouchi)

2nd place TAD TAD-CE1TX ¥2,700,000 (pair)



- A new product that has improved the key points of the previous model, which had a reputation for sound quality, and has achieved even more detailed and vivid sound. The dimensions of the enclosure have also been slightly changed, and the crossover point has also been revised. The processing process for the woofer diaphragm, which is made of five layers of aramid woven fabric and non-woven fabric, has also been changed, resulting in wider low-frequency clarity. I like the realistic depiction of the music, which also exudes TAD's rigor. (Miura)
- TAD has played an extremely important role in expanding the expressive range of small speakers, and the previous generation CE1 is no exception. With the generation change to CE1TX, the quality of sound has improved, especially from the ultra-low to low frequencies, and the visibility of the sound field has reached an unprecedented level. It's been a long time since I last bought a model, so I had to be brave enough to buy it, but I think it's worth the high value. (Yamanouchi)

5th place Maju A3 ¥1,950,000 (pair)



• Magico sound
The core and top
batter of the A series,
realized at a minimum
price. It has probably been
developed over time
and has a high degree
of perfection,
producing a light and clear
sound across the
entire range. As expected,
the bass range due to
the closed type is
characteristic, and the low
end is tight and clear.

Stop★
Mayuzumi
Three right Yamanouchi
Score 6
The presentation of a uniform sound can be said to be an attractive feature that is difficult to obtain with the bass reflex system. The installation area is compact, about the size of an LP jacket. (Mitsuru)

3rd place Marten Parker Duo Diamond Edition ¥2,850,000 (pair)



Small field★
Fu★
Score 7
Mitsuru Yamanouchi

•Sweden's Marten has various series named after jazz giants, and the Parker series is characterized by its dynamic sound that makes good use of a passive radiator. This machine is a 2-way machine with a bass radiator on the back, and is a special edition that features diamonds as a ton eater. A truly high-quality and precise sound world expands and expands. (Onodera) •When you see the actual product, you will be surprised at the beauty of the finish. The surface of the enclosure is like a mirror. The sound is very precise, and its biggest feature is that it has a clear sound that doesn't make you aware of the bold use of the latest materials. The vocals are glossy and moist, and you can enjoy the moist and flavorful sound. It is also a sound that draws the listener into the world of this speaker and makes them hypnotized. (Mayuzumi)

6th place Piega Coax 611 (black/with bottom plate) ¥2,840,000 (pair)



•By reviewing the structure of the ribbon unit to accommodate human width, the quality of the mid- and high-frequency ranges has been improved over a wide range, creating a sound that is different from the combined model number speakers of the same Coax series. Unwanted resonance in enclosures has been minimal for some time, but push-pull tension, and the quality of the bass has also been clearly improved. (Yamanouchi)

Onodera
Fu★
Mayuzumi
Yamanouchi
Score 5
It is the pioneer of a new mechanism that optimizes the tension, and the quality of the bass has also been clearly improved. (Yamanouchi)

6th place Avalon Precision Monitor 1 ¥2,800,000 (pair)



•New series Precision Monitor (PM) is Super class model Including recent in speaker development Know-how learned I added cor. workman enclosure The material is wood from the past. Made of new material, not made of Composed of wood. This machine is of the PM series My youngest brother. Ho What a nice person. vinegar

Ono 600 million
Score
A smooth and natural sound. The sound has no peculiarities, so when the music starts, the presence of the five speakers disappears. (fuu)

Dynaudio Contour 60i ¥1,650,000 (pair)



•The 60i, which was the only model in the Contour series whose introduction was delayed, has finally been delivered to customers, and we can see the same dramatic evolution as its sister machines in the series. Highly precise harmonies based on the support of low-frequency instruments with a clear and low center of gravity are expanded, and the structure of the piece and the synchronization of the instruments are expanded.

Makoto Onodera
Yamanouchi
Score
Describe the above relationship in detail. Scale only to the top of the series 3's personality is also exceptional. (Yamanouchi)

8th place TAD TAD-E1TX ¥2,400,000 (pair)



•4 years since release
After that, TAD continues
to produce
wonderful speaker systems.
but this year I
listened to this unit again
and was reconfirmed
that its charm has not
faded in the slightest.
Based on the fineness
typical of Japanese
products, it also
has a rich sense of
color. The balance between
the sound field

八野寸

Score 3 Sound with added dynamism. Fulfilling and light and sound image is also very good. The flavor is also attractive. (Onodera)

8th place Yamaha NS5000 ¥1,800,000 (pair)



•Flagship machine that temporarily uses woven fabric of Japanese-born chemical fiber ZYLON (ZYLON) for all vibrations. It is reminiscent of the closed type NS10 00M from 2010, but the bass reflex system also ensures a sense of volume. The good responsiveness is due to the characteristic of Zylon fiber, which is the speed of sound, which is comparable to beryllium.

Mayuzumi★
Miura★
Yamanouchi★

Score 3 Does it depend? A seamless sound feel is obtained throughout the entire area, making the music. The texture is carefully and delicately drawn. (Miura)

8th place Esteron YBMkII ¥2,720,000 (pair)



•At first, I felt strange about its unusual appearance, but as improvements were made and the sound improved, I started to get used to the moon. YB became MkII, and the sound became clearer and the realism was greatly improved. The sound image has become lighter and more three-dimensional. This is because the S/N feeling has improved.

Mayuzumi★
Miura★
Yamanouchi★

Score 3 "I get the impression that the background of the deaf music has become much quieter, and the expressiveness of the performers has improved tremendously." (Mayuzumi)

BEST BUY COMPONENTS

speaker system

320-

More than 10,000 yen

12th place	Dynaudio Confidence 20	¥1,700,000	Yamanouchi★	Miura★
	pink team KIM	¥1,800,000	Haa: 博★★	
	Accordo Essence	¥1,950,000	Yamanouchi★★	
	Magico S1 Mk2 (M-CAST)	¥2,750,000	Bear: Miura★★	
	B&W 803D4 (Rosenut)	¥2,980,000	Pair: Dot★★	
17th place	Dation Anima This Eureka	¥1,600,000	A Small 守★	
	KISOアコースティック HB-X1	¥1,700,000	Hair! Niura★	
	quad ESL2812	¥2,100,000	A Small 守★	

2nd place Esteron XB Diamond Mk II ¥5,800,000 (pair)



•This is a speaker made in Estonia, and the model name says Diamond. Listening to the steel-string acoustic guitar and the wild percussion, you can clearly see the power of the diamond tweeter. The enclosure, which is made of a composite material that does not easily cause resonance, has no sharp corners in the hydraulic direction, so the angle of internal swing can be determined freely. A beautiful sound with a shining luster. (fuu)

•Elegant design is backed by technology and has necessity. Although it may not be visible in , devising the enclosure material to eliminate resonance is also part of our unique know-how. The latest generation model, which uses carefully selected materials, has a richer tone and resonant texture, and has a dynamic range that is far greater than previous models without reaching saturation. even when listening to works with a large number of sounds. (Yamanouchi)

4th B&W 802D4 (Gloss Black) ¥3,960,000 (pair)



Improved drain damper. I realized that I was listening to the sound of the damper through the cone. Expressions rich in nuance. (den)

•See 801D4
After that I heard to the wood machine.
When you meet this practical personality
Make me think it's the limit
It will be done. Import source
B&W in Japan
The person who knows the most about.
According to things, before
The 802D3 made by
Six tatami room (low sound
exit to the outside)
sound well with
There are cases where
is. In the D4 version, Mi

First place B&W 801D4 (Gloss Black) ¥4,960,000 (pair)



•Unlike the separate 802D4, the size of this unit may seem overwhelming, but it still stands out in terms of the volume and thickness of the sound, and the depth of its expressive power. The company is a mass producer of Hi-End speakers. How much will it cost if it is handmade in small quantities? The bass has ultra-low distortion, perfect physical characteristics, and unbiased musical expression ability. This is a reference for the stereo sound listening room. (fuu)

•Although it shares the same characteristics as the previous 800D3 in terms of highly accurate sound, the number of sounds has clearly increased and the power of expression has improved. The two woofers have been changed to a single damper structure, making it a single speaker that is easier to play from the amplifier's perspective, which is a welcome evolution. By becoming more sensitive to sounds in general, you will be able to discover sounds from familiar sound sources that were previously difficult to notice. (Miura)

3rd place Magico A5 ¥3,800,000 (Hair)



•The problem with Magico is that the sound is good, but it's expensive. However, the A series has made Magico much more familiar. The sound is cutting-edge and cutting-edge, just like the high-end models. In order to bring out the true potential of this speaker, you need to be skilled at setting and tuning, and I want you to know that you must also have the willpower to complete the task. Beyond that, Togenkyo awaits. (Mayuzumi)

•This unit, the largest in the A series, is equipped with a newly developed graphene nanotech multi-layer diaphragm that has a spherical shape, just like the flagship model M9. Technological advances can also be seen, such as the use of a new foil resistor with a heat sink for the crossover element. The precision of expression that is the appeal of the A series is complemented by the advantage of expanded dynamic range, allowing you to hear sounds that are full of life. (Miura)

5th place Wilson Audio Sasha DAW (Standard) ¥6,900,000 (Bear)



•The Sasha DAW, named after the founder, is an important product that plays the role of passing on the brand's tradition to the next generation. By paying close attention to every detail, we have achieved a level of perfection that is exceptional among the company's products. In addition to highly accurate spatial representation

★
Miluna
Kamouchi

Score Achieves high-density sound with strong penetrating power, presenting a highly fresh sound that does not fade over time. (Yamanouchi)

5th place Fine Audio Vintage Twelve ×4,700,000 (Bear)



•Horn type coaxial 2-way tradition from Tannoy fine ode I will take over It seems like it's gone. Shinto vintage of place Ji is a traditional de It is characterized by zine, Tannoy here too I feel like I've surpassed be. Dubbed Bass etc. Click without coming out. The edge is

★
Onodera
Fu★

Score: That's a clear statement. It sounds like a "message," so to speak, and there is not the slightest weakness in it. The resolute expression of the violin was wonderful. (Mayuzumi)

7th place TAD TAD-CR1TX ¥7,000,000 (pair)



•The sound of the CR1TX, which reigns in the reference series along with the TAD-R1TX, overturns the preconceived notion of a bookshelf speaker, allowing you to experience a world on a different level than existing small speakers. From the faint sound of disappearing people to the loud sound of tutti, the tension loosens.

★
Ura
★
★
★

points His sound is unique and has a consistent density without any distortion, and his powerful expression is unrivaled. (Yamanouchi)

7th place German Physics HRS130 (High Polish Black) ¥4,200,000 (Bare)



•German jar man physics It's been a long time since Landing again on Thursday, the company speaker system Tim's key is water flat omnidirectional ending way Features DDD unit to. This machine is DDD Maximize the characteristics of In order to make use of - Fur inside Stored in the whole area

★
Onodera
Fu★
★
Yamanouchi

Achieve water omnidirectionality with the score. 3 A new solid sound image description has been added to the comfort of sound spreading throughout the room. (Onodera)

7th place Magico M2 ¥11,700,000 (pair)



-Same as M6 and M9 Adopting a carbon fiber composite enclosure ensures rigidity and ample volume in a closed design. Each driver is the same as the M3, and the special feature is that the baffle width is kept to a minimum, keeping the total weight to about 75kg. This is Woo

★
Ura★

Score Since it has two fur units, its sense of scale is not as good as the M3, but its high-definition, realistic sound is comparable. (Ura)

7th place Avalon Precision Monitor 3 ¥7,500,000 (pair)



•Surge in prices More personal (The vest that was provided Upper limit for bye selection The amount is 6 million yen to 8 million yen up (in either case) As much as Seiko Based on the price of the product Stobai concept doesn't suit you Deaf). Of course This increases the upper limit This is the recommended combination I'm happy to recommend it

★
Onodera
Fu★

score It's beautiful. The company is unique in its superb sound that goes beyond simple hi-fi and is faithful to the style of music. (Onodera)



2nd place

Denon DCD900NE ¥70,000



Xiaofu ★★

緑 ★★

Miura ★

Yamanouchi ★★

points 9

•Although there are fewer options for building an introductory system using full-size components, this machine, which has been released for the first time in a while from Denon, has elements that disc enthusiasts will appreciate. The design has been thoroughly designed to improve sound quality by enlarging the housing and making more room for the board size. Its success lies in the combination of careful depiction of details and relaxed spatial expression.

You can hear the results.

(Yamanouchi)

4th

Marantz CD60 ¥100,000



den ★★

緑 ★★

Yamanouchi ★★

score

•This unit can be said to be a great value model for people who only listen to CDs. The sound is lively and full of charm, and the vocals are glossy and good at reproducing nuances, making them very charming. The high level of basic performance can be seen from the fact that it accurately depicts the characteristics of the performance.

The dynamics of a jazz big band or other music are accurately expressed, and the performance sounds like it has a good rhythm; (Mayuzumi)

11th

place	Franco Sebanquin	Ktoma	¥1,500,000	小野 ★★
	Paradigm	Persona 7F	¥4,800,000 (pair)	三浦 ★
	funk game borg		¥1,800,000	三浦 ★
	marden	Parker Quintet Diamond Edition	¥5,800,000 (pair)	小野 ★
	vivid audio	GIYA G3-S2 EX	¥6,200,000 (pair)	★★
	Denloudens	Confidence 60	¥6,800,000 (pair)	三浦 ★★★
	Vivid Audio	GIYA G2-S2 EX	¥7,300,000 (pair)	★★
	Avalon	Precision Monitor 4	¥9,720,000 (pair)	三浦 ★★
	Magico	M3	¥14,300,000 (pair)	三浦 ★★

20th

place	Paradigm	Persona 5F	¥3,200,000	★
	Dynaudio	Confidence 30	¥3,300,000 (pair)	小野 ★
	KIX)	Acoustic HB-G1	¥4,500,000 (bear)	三浦 ★
	Sossu Faber	Il Cremonese	¥5,800,000 (pair)	三浦 ★
	Piega	Master Line Source 3	¥7,500,000 (pair)	★
	YG Ani Styx	Hailey 2.2	¥8,800,000	三浦 ★
	Marten	Mingus Quintet 2 Statement Edition	¥10,000,000 (Bear)	★
	T.A.D.	TAD-R1TX	¥14,000,000	Miura ★
	アノ	Kore	¥15,000,000 (Bear)	Miura ★
	Esteron	Forza	¥15,500,000 (pair)	Miura ★
	YC acoustics	Sonja 2.2i	¥15,800,000 (Miura)	★

First place

Marantz SACD 300 ¥298,000



小野 ★★

神 ★★

緑 ★★

Miura ★★

Yamanouchi ★★

points

CD | SACD2ch

•An SACD/CD player equipped with a mechanical engine developed by Hakusha, a discrete DAC (PCM signals are converted to 11.2MHz DSD signals), and a newly designed front panel. It is not only a disc player, but also a network function, allowing you to easily use each function.

Scoring: The clock connection is perfect. Of course there are external inputs, including a USB 15 that can be connected to the built-in DAC. It has a clear and nice sound. (fuu)

3rd place

Marantz CD6007 ¥62,500



Onodera ★★

神 ★

三浦 ★

Miura ★

Yamanouchi ★

score 7

•Although the selection of digital disc players is much smaller than it used to be, it's really reliable that Marantz and Denon offer a lineup of great products at reasonable prices. This machine is a CD only machine. I got used to it in a good way.

Plays music with just the right amount of construction. Equipped with a full-fledged analog circuit, you can enjoy the excellent texture.

(Onodera)

5th place

place	Denon	DCD600NE	¥53,000	Ono Sanzan ★
	Arkham	CDS50	¥130,000	★★

First place

Luxman D07X ¥750,000



Fu Onodera ★★

録 ★★

Miura ★★

Yamanouchi ★★

points

14

CD | SACD2ch

•Luxman used to be a manufacturer specializing in amplifiers (including vacuum tube amplifiers), but now it is also a respectable disc player company. It seems that many people want a disc player that pairs well with an amp with the same design. The wooden machine is an SACD/CD player equipped with a mechanical engine designed to prevent vibrations, a DAC section equipped with a ROHM DAC chip, and a discrete output stage. Bright and smooth sound. (fuu)



2nd place

Marantz SA12 OSE ¥350,000



Fu OnoderaFu ★★

録 ★★

Miura Yamanouchi ★★

★

score

10

CD | SACD2ch

•High C/P premium machine that thoroughly pursues sound quality as OSE=Original Special Edition based on SA12. In addition to a solid aluminum insulator and a copper-plated chassis, the exterior is enhanced with a 5mm thick top cover, and a new metal film resistor is used to tune the sound quality. Monologue's discrete DAC, which processes everything with 1 bit, is also an attractive feature. (Miura)

2nd place Technics SL-G700M2 ¥370,000 (tax included)



Onodera ★★

Den ★★

録 ★★

二録 ★★

Yamanouchi ★

score

Another appeal is that 10 can be heard clearly. (Mayuzumi)

CD | SACD2ch

•This is probably the result of development focused on high-precision D/A conversion, such as minimizing amplitude and phase shifts and improving the reproducibility of impulse signals. The sound image is three-dimensional and clearly localized, and the sound like the gaps between the notes. The S/N feeling is very good, and a transparent sound field spreads out before your eyes. The resolution is also excellent, and while it has a sense of volume, it

5th place

Denon DCD-A110 ¥306,000



Onodera ★

録 ★

Mayuzumi ★★

Yamanouchi ★

Score

5

CD | SACD2ch

-The company's digital model, which was introduced two years ago as a commemorative model for the 110th anniversary of its founding. A product that is the culmination of digital disc player technology. upsamp PCM digital signal to 1.536MHz by ring & bit expansion processing. Conversion processing to 32bit and use of 4 DAC chips in the D/A converter section achieve high sound quality. Although he tends to listen to music analytically, he is a talented performer who accurately reproduces the performers' expressions. (Mayuzumi)

4th place Accuphase DP570 ¥680,000



Ono is ★★

録 ★

録 ★

Miura Yamanouchi ★★

★

Score

7

CD | SACD2ch

•Retailers who are looking for a highly reliable player that supports SACD. The DP570 is recommended for snares with confidence. Although it is easier to obtain than the higher-end DP750, the performance of the audio circuit is not significantly inferior, and the operation of the mechanical drive is reliable. The amount of information you can rely on is suitable for an upper-middle class. (Yamanouchi)

5th place Marantz SA10 ¥600,000



den ★

Mayuzumi ★

Miura ★

Yamanouchi ★★

Score

5

CD | SACD2ch

•This is the first model equipped with Marantz's uniquely designed discrete DAC, and the configuration in which the PCM signal is converted to DSD and passed to a low-pass filter has been followed by subsequent product groups. Considering the current harsh environment such as difficulty in obtaining parts, it was a wise decision for the company to start development early. The sound is precise but not dry, rich in emotion and with a high sense of temperature. (Yamanouchi)

8th place Luxman D03X ¥300,000



Onodera ★

Miura ★

Miura ★

Yamanouchi ★

Score

4

•This is an entry-class product among Luxman's full-size digital players, developed around the same time as the flagship model D10X. Even though it is an entry-level product, there are no omissions in terms of content, and it achieves high-quality sound by being equipped with a fully balanced output circuit. Yet, it has a unique charm that creates a friendly atmosphere. (Onodera)

11th place ヤマウチ CD-S3000 ¥480,000 Miura Yamauchi★

12th place Derin DCD-SX11 ¥400,000 Miura★

5th place Accuphase DP450 ¥390,000



den ★

Fuu ★

Miura ★

Yamanouchi ★

Score

5

CD

•A CD player made by Accuphase that is extremely popular. CD mechanical engine with anti-vibration structure, 4 circuits (using ESS ES9026PRO) driven in parallel to eliminate conversion errors of individual elements. This is a scaled-down version of the technology cultivated in higher-end models, such as the MDS+ D/A converter section. I have a lot on my audiophile shelf. He has the ability to be trusted when listening to CDs again. (den)

8th place Triode TRV-CD6SE ¥300,000



den ★★

Miura ★

Yamanouchi ★

Score

4

CD

•The company is a manufacturer of vacuum tube amplifiers, and there is demand for paired CD players. This unit has semiconductor output (balanced, single-ended) and vacuum tube buffer amplifier output (single-ended only). Equipped with both. The vacuum tube output has been increased to a warm, soft sound, which is the standard image of vacuum tubes. We left the user with an enjoyable choice. (fuu)

10th place Mark Levinson No5101 ¥650,000



den ★

Mayuzumi ★

Miura ★

Score

3

CD | SACD2ch

•This machine is based on Mark Levinson's PurePath philosophy. The analog stage features a fresh sound with rhythmic and light footwork. In addition to SACD and CD playback, USB memory and Another feature is that it is a multi-purpose machine that also supports UPnP DLNA network and streaming playback. The drive mechanism uses a slot-in method due to design considerations. (Ura)

1st place

Soul Note S3 ver.2 ¥1,490,000



CD | SACD2ch

•A radical model that thoroughly pursues sound quality, including an NOS design that aims to accurately reproduce the time axis, a unique housing structure, and a powerful analog circuit. It goes without saying that it has a large number of sounds, but its greatest appeal is its crisp and clear dynamic reproduction. We strongly recommend upgrading to the reference specification and connecting the separately sold X3 clock.

Although it costs more, it is still a best buy.

(Onodera)

Onodera

値 ★

録 ★

Mitura

Yamanouchi

points 10



3rd place

Esoteric Grandioso K1X ¥2,900,000



CD | SACD2ch

•I prefer an integrated type that is easier to handle than a separate type, but I don't want to compromise on performance. Here are the best options when choosing an integrated type for such emotional reasons. VRDS ATLAS is the same as P1X and the discrete DAC is also virtually the same. The essential sounds are also very subtle, and the richness of the textures and high dynamic resolution are almost on par.

(Yamanouchi)

値 ★

録 ★

Mitura

Yamanouchi

Score 9

1st place Accuphase DP1000+DC1000 ¥2,600,000 (set)



CD | SACD2ch

•I've been using the previous DP950/DC950 for five years and had no complaints, but when I listened to the DP1000/DC1000, I was surprised at how much they had evolved. I ordered it immediately, but it was not available until 6 months later, showing how popular it was. In addition to what could be described as an outstandingly stable sound field, the dynamism of the music is wonderful. Like Masterings (Mayuzumi)

It's a vivid sound that makes you feel like you're listening to it in a studio.

Onodera

Den★

録 ★

Mitura

Yamanouchi

points 10

5th place

Accuphase DP750 ¥1,270,000



CD | SACD2ch

•This is the highest-end disc player among Accuphase's all-in-one models. The configuration of the D/A conversion circuit is similar to that of a separate DAC, and the exterior with a base exudes the beauty that is unique to a flagship. Absolutely Dynamic, from the contrasting sense of calm to the strong instantaneous power of tutti.

The range has plenty of room to stand out from lower-end models, and the precision of spatial depiction 6 degrees is extremely high.

(Kawanouchi)

Mitsuo Ono

FU★

録 ★

Mitura

Yamanouchi

score 6

4th place Esoteric K01XD ¥1,850,000



CD | SACD2ch

•The achievements that Esoteric has made in the world of digital disc players are unparalleled. In addition to the world's highest-rated disc drive mechanical engine, Esoteric has recently attracted attention for the development of its unique discrete DAC. This unit has achieved a solid and stable sound through the company's thorough input of materials. Texture description is accurate and of high quality.

[Onodera]

Onoko

FU★

録 ★

Mitura

Yamanouchi

Score 7

5th place CH Precision D1.5 ¥5,550,000



CD | SACD2ch

•Switzerland's CH Precision first appeared before us with the digital disc player D1. Another feature was that it was equipped with a slot on the back for expandability. This machine has the disk drive mechanism of the D1 replaced from Esoteric to D&M, but other than that it is the same. A joyful sound that adds solidity to the monologue's colorful appeal. (Onodera)

Den Onodera

Yamanouchi

points 6

5th place Luxman D10X ¥1,300,000



CD | SACD2ch

•A flagship model that attracted a lot of attention when it adopted ROHM's high-end DAC for the first time, and its sister model, the D07X, which leveraged the know-how gained through the development of this model, also received high praise. This is an important product that determined the flow of Luxman's next-generation machines. In addition to the advantage of physical characteristics, there is an active musical expression that actively brings out the expression of the performance. (Yamanouchi)

Hachinohe

Shin

Shin

Ufa

Ufa

Ufa

score

9th place TAD TAD-D1000TX ¥2,100,000



CD | SACD2ch

•For clocks, a high CN ratio (carrier-to-noise ratio) is more important than long-term time accuracy; extremely low jitter improves the purity of digital signals, and clocks bring quietness to the sound. TAD taught me this. The wooden machine is an SACD/CD player, but efforts are being made to improve the sound quality of the built-in DAC using USB human power. on the specs accepts up to PCM384Hz and DSD11.2MHz. (fuu)

Onodera

Miura

score 4

8th place Esoteric K03XD ¥1,200,000



CD | SACD2ch

•The K01XD is a high-end model, but it achieves high sound quality with the VRDS ATLAS03 drive mechanism and Monologue's discrete DAC circuit. The performance of each factor is very good, and I recommend it as a best buy machine that will bring you a full-fledged game disc. High-resolution compatible USB input is PCM with 384kHz/32bit and DSD 5 can internally generate up to 22.6MHz (DSD512). (Miura)

Onodera

Shin

Shin

Miura

Ufa

score

9th place Metronome t | AQWO+c | AQWO ¥6,800,000 (Set:



CD | SACD2ch

•There are sounds that can only be heard with this combination, and they are incredibly appealing, so once you're hooked, you won't be able to break free. The sound is extremely clear, with no hint of impurities, and while it is highly transparent, there is no hint of cold or anything, and it gives off a lustrous luster. I don't remember ever listening to a digital disc player with such beautiful sound. (Mayuzumi)

Onodera No.

Miura

Yamanouchi

score

9th place Esoteric Grandioso K1X+PS1 ¥4,200,000 (set)



CD | SACD2ch

- Esoteric's highest grade series, Grandioso integrated type This SACD/CD player is equipped with the company's proprietary VRDS mechanical engine and discrete D/A converter. K1X is enough It makes a nice sound, but when you add the PS1 reinforced power supply, the words become louder. The less it comes out, the better the sound. I can't take it off anymore. Special features for audio equipment I was reminded that the power supply was cut off. (Shin)

Fu

Shin

score 4

Digital Disc Player 1 million yen or more

13th place	Macintosh MCD600	¥1,020,000	Fu★★ ACS
	Rossini	Transport + APEX DAC	¥7,520,000: Sefu Yamauchi★
15th place	Metronome	¥2,600,000	¥4,200,000 珠 ★
	Le Lucke-Sains MPS8 AQWO		Yamanouchi★
	Playback Designs MPT8+MPD8 dCS	¥6,900,000	比:内 止之内★
	Vivaldi	System (APEX DAC ¥17,250,000)	Miura★

9th place Esoteric Grandioso P1X+D1X ¥7,200,000: Set



den★
Nothing★
CD | SACD2ch
Miura★
Yamanouchi★
Score 4

•The company's best model pair. The world's highest level of majesty. The SACD/CD transport is equipped with VRDS, a top-of-the-line model ATLAS (weighing 13.5 kg including the base), which rotates the disc without vibration to read microscopic signals with high precision. The D/A converter section is a monophonic type, which is rare in the world, and has a discrete configuration by the company. The sound is pouring out from the disc.

First place Accuphase DP1000 ¥1,300,000



Fu Onodera★★★
珠★★★
Miura Yamanouchi★
score 11

•The pair of AccuFoods separate players DP1000 + DC1000 is dignified and deep, expressing the deep shadows of the songs and conveying the song's heart. This is exactly the sound achieved by the pair, but when you listen to it alone, you can feel the power of the DP1000. This is because the sound is solid and dignified, whether playing SACDs or CDs. It will definitely revive the discs that are sleeping on your shelf. (fuu)



3rd place New Prime CDT8 ¥200,000



Onodera★★★
Fu★
score 4

•The digital disc transport genre is currently a standalone genre. I don't think it will come to fruition. Most products come in pairs. It has a D/A converter that connects using a proprietary standard for SACD playback. This is because it is a special product. In that sense, Best Buy sells books. Push the machine. Because it is exclusively for CDs, it is highly versatile and can be used even if the drive mechanism is malfunctioning.

4 Revive the player. (Onodera)

1st place Esoteric Grandioso P1X ¥3,600,000



Ono is★★★
Fu★★★
珠★★★
Miura Yamanouchi★★★
score 11

•SACD playback is limited to combination with the company's DAC (ES-LINK). Despite the fact that it is a development that pursues the ultimate in optical disc playback. We chose a wooden machine out of respect for the strength and material input. Newly developed Power supply unit with 4 power supply configuration using VRDS-ATLAS drive mechanism and separate housing. Disk transport on a scale larger than this unit, such as knitting, is no longer available.

11 It makes you think that he will not appear. [Ura]

4th PS Audio PerfectWave SACD Transport ¥900,000



Onodera ★
Miura ★★
points 3

•SACD/CD transport that can transmit SACD DSD by connecting the company's DAC to IS (using an HDMI cable). The drive mechanism seems to be made by D&M and also supports playback of discs containing digital file data (DSD PCM). In addition to the current product, the DirectStream DACII, which is scheduled to be released, will be able to internally record SACD. (Miura)

4th New Prime, CDT9 ¥220,000



★
★
score

•When adding a CD playback function to a system based on the DAC9X, a preamplifier with a built-in DAC, and a minimum-sized power amplifier, it is reasonable to add this unit that uses the transport system. Not only will the sound quality be consistent, but the design will also be consistent. 3 Benefits include quiet operation unique to single speed, which rotates at high speed and does not read data in advance. (Yamanouchi)

4th dCS Rossini Transport ¥3,450,000



★
★
Yamanouchi ★

•The Rossini series has an integrated Rossini Player, but it only plays CDs using an Austrian-made mechanical engine. By combining this transport with a Rossini DAC, you can play SACDs. The paired Rossini DAC is now the APEX version, and its score has improved dramatically. Moreover, it is not only possible to play discs.
3 | Connect to the network and expand your music world.

4th place Playback Designs MPT8 ¥3,200,000



★
★

•This CD/SACD transport was developed to be used in combination with the MPD8, which is equipped with a proprietary discrete DAC, and the best sound can be obtained by using the proprietary P-Link connection between the two. ★ It is better to connect external digital devices via the wooden machine's digital input. Incidental sounds and noise are wiped out, creating a sound field with a wide open field of view. (Yamanouchi)

9th place Macintosh MCT500	¥700,000	★
Esoteric P05X	¥750,000	Ura★
tronome t AQWO	¥3,400,000	Miura★

8th place Oracle	CD2000 MKIV	¥2,100,000	★★
------------------	-------------	------------	----



1st place Soul Note D2 ¥660,000



onodera value ★★★★★
 業 ★★★★★
 Milura ★★★★★
 Yamanouchi ★★★★★
 Score 15

USB compatible

●This is a brand whose products are created through the work of a small, elite group of about 50 people. The core DAC chip uses two ESS ES9038 PRO channels per channel and is equipped with an ultra-low jitter clock circuit. Filter has non-oversampling mode and USB input. It has unique features such as the use of a special bulk transfer method for connection with computers. It sounds really raw. (博)



3rd place Code Qutest OPFN (around ¥250,000)



Fu★ ★★★★★
 Milura ★★★★★
 Yamanouchi ★★★★★
 Score 4

USB compatible

●Cord is a brand from the UK that started with analog amplifiers, but now they have an extensive lineup of digital equipment. The wooden machine is a small D/A converter that looks just like a portable machine, but it has a lot more functionality. It has a built-in powerful FPGA and performs high-order upsampling processing (high-speed calculations). Just because it's small, it's only for desktop use. It makes a wonderful sound that never stops. (fuu)

2nd place Sforzato DSC-Grus ¥300,000



Fu★ ★★★★★
 Milura ★★★★★
 Yamanouchi ★★★★★
 Score 6

USB compatible

●It is a USB-connected DAC with two USB terminals, but it also has the much-talked-about ZERO-LINK, so it is possible to connect a compatible transport. The DAC elements are two ESS ES9038PRO. It also features a three-system power supply section: digital/analog/analog. A 10MHz master clock input via SMA terminal is standard, and a coaxial digital input can be added. (Ura)

! New Prime DAC9X ¥210,000



業 ★★★★★
 Milura ★★★★★
 Yamanouchi ★★★★★
 Score 4

USB compatible

●Stylish and slim housing design with a width of only 235mm. Excellent. How to fully enjoy the unique charm of New Prime. I think the correct answer is to choose a product group of Riko's size. Input is digital. The main input is analog input, but there is also one analog input system, and the applications covered are Scoring Surprisingly wide. It inherits the wide range and responsive sound common to this brand. (Yamanouchi)

3rd place Soul Note D1N ¥350,000



Milura ★★★★★
 Yamanouchi ★★★★★
 Score 4

USB compatible

●The DAC element uses ESS ES9038PRO independently on the left and right sides, and is new. It also supports NOS (non-oversampling). General. In addition to digital input, PCM with 768kHz 32bit and DSD. Equipped with high-resolution compatible USB input up to 22.6MHz (DSD512). This is a high-quality non-feedback DAC. The power supply section is also well-equipped. The uncompromising design typical of Lenaut has been thoroughly implemented. (Ura)

7th place 1st place Specs	コード Hugo 2 OPFN (tax included Y299,981)	↓2P ★
	RMP-DAC3 ¥380,000	↓2P ★

6th place specs	RMP-DAC1	¥320,000 ★★
-----------------	----------	-------------

First place
Soul Note D3 ¥1,680,000



USB compatible

Den Onodera ★★

機 ★★

Yamanouchi ★★

points
11

•It is interesting that the sound quality has been improved by deliberately not including a clock. Motoki is used in conjunction with the X3, which the company recommends as a clock generator, and then connected to the ZERO LINK connection to the Z3. It brings out a clear sound field and a clear grain that makes you feel the momentum of each note. It perfectly aligns with other Soul Note products in terms of old-fashioned intentions, and there is no deviation. (Yamanouchi)

3rd place
Accuphase DC1000 ¥1,300,000



USB compatible

Onodera ★★

機 ★★

Yamanouchi ★★

score
7

•When connected to the company's disc transport DP1000 using the company's proprietary interface, SACDs can be played and CDs also sound better. It should be considered a complete pair. It is full of the company's unique technologies, such as a D/A converter section using the MDS++ conversion method that drives multiple DAC circuits in parallel, and one output filter circuit in parallel. 7 A wealth of information, high resolution, and an honest tone with no gaps. (fuu)

5th place
Esoteric N05XD ¥850,000



USB LAN compatible

機 ★★

Miura ★★

Yamanouchi ★★

score
7

•Not only compatible with network playback, but also compatible with the company's transport. It can also be used in combination as a D/A converter compatible with SACD, making it a full-fledged. A multi-functional, super-value product that also includes a balanced dual-mono preamplifier. Thanks to the discrete D/A converter developed by Hakusha, you can hear vivid and clear sound. I was also surprised by the overwhelming number of sounds. (Mayuzumi)

BEST STO
BUY
D/A converter
COMPONENTS
700,000
yen or more

2nd place
Esoteric NO1XD ¥1,600,000



USB/LAN compatible

Hakusha Fu ★★

Miura ★★

LINK ★

score
8

•A D/A converter that not only connects to the company's disk transport using a unique method (ES-LINK), but also connects to LAN and USB. The stable sound with a low center of gravity is unique to disc playback, and Kiki has dispelled the impression that file playback still lacks deep bass. Presents a dignified sonic balance during file playback. Accepts DSD22.5MHz. (fuu)

4th place
TAD TAD-DA1000TX ¥1,500,000



USB compatible

Hakusha Single ★★

Fu ★★

Miura ★★

LINK ★

score
6

-Renewed with the USB transmission engine developed by Soliloquy. DSD with the Volition series D/A converter. Compatibility with 11.2MHz signals has also been realized. A sound that combines energy balance with a low center-of gravity and precise reproduction of detail is a common virtue of TAD components. You can hear the results of our efforts to improve the performance of the clock and power supply circuits. (Yamanouchi)

7th place

Code DAVE ¥2,200,000



USB compatible

Onodera ★

Shin ★

Miura ★

score 3

•The fact that it has been a long-seller for six years since its release is proof that we are still hearing cutting-edge sound. The combination of high-order oversampling by a high-performance FPGA and a discrete pulse array DAC brings vivid analog sound from digital sound sources. When combined with the company's Hugo M Scaler, further oversampling processing can be achieved. (Miura)

5th place Merging Technologies Merging NADAC (stereo) ¥1,400,000



LAN compatible

8. Ritsui Nodera ★

Shin ★

Miura ★

score

•Adding a strengthened power supply strengthens the sound structure, makes the space quieter, and improves the visibility of the sound field. The change in sound quality that is unique to NADAC is interesting, and is different from strengthening the power supply of an amplifier or the like. Furthermore, by adding a clock, the noise of the sound is removed and the reproduction of minute nuances is greatly improved. All of these programs are designed to improve sound quality and make this unit's high performance possible. (Fu)

7th place

MSB Technology Discrete DAC Plus ¥3,180,000



USB LAN compatible (optional)

Shin ★★

score 3

•Premium specification that combines the company's entry-level discrete DAC with the full-size power supply of the higher-end model. Equipped with PCM DSD compatible discrete DAC modules "PRIME DAC" on the left and right sides, in addition to general digital inputs, up to two human-powered modules (sold separately) can be installed. This is a full-fledged, high-quality DAC that specializes in precise and complex musical expression. (Ura)

7th place dCS Bartók DAC ¥2,770,000



USB LAN compatible

Onodera ★

Shin ★

score 3

•Ring-DAC, which forms the core of the company's technology, is equipped with an advanced version of the 8th generation Ring-DAC. The Ring-DAC is a discrete circuit with six types of PCM and five types of DSD filters. There is a model with a built-in headphone amplifier that is popular among advanced headphone listeners, and is equipped with a function that allows you to hear headphones clearly. (Fu)

dCS Vivaldi APEX DAC ¥5,290,000



USB compatible

Onodera ★★

Miura ★

score 3

•The British company dCS has been developing so-called discrete D/A converters for many years and is achieving remarkable results every day. Vivaldi, which ranks at the top of the range, has evolved to the APEX specification through a thorough review of each part. The original model had a wonderful high, but the latest version has an exceptional sound that is even better than that. (Onodera)

7th place Esoteric Grandioso D1X ¥3,600,000



USB compatible

Onodera ★

Shin ★

Miura ★

score 3

•Three and a half years have passed since the debut of this monumental Esoteric D/A converter, but it still reigns as the brand's flagship. The in-house developed discrete DAC is a luxury product made with high-grade parts, and it greatly contributes to the realization of a sound that is clearly different from that of general-purpose DAC chips. Anyway, the "realism" of the words is amazing. I was surprised by the sense of stability and low center of gravity. (Mayuzumi)

15th place

de	HugoTT 2	¥1,100,000	Shin ★
dCS	Rossini APEX DAC	¥4,070,000	Tilt ★

12th place Sforzer DSC-Dorado

Sforzato DSC-Vela	¥900,000	Nofu ★★	
Ogura	Tube DAC	¥3,372,000	Shin ★★

1st place Soul Note Zero Link Ultimate System ¥3,210,000(Z)



USB LAN (SFP) compatible

•This is Soul Note's ultimate system for playing sound sources via USB or network connections. This is a combination of ZERO-LINK, which sends a high-order master clock signal from the DAC side to the transport and synchronously transmits digital signals, and a 10MHz square wave master clock. The sound is surprisingly clear and dynamic. We can expect much from this technology in the future. (Miura)

Score 9

3rd place Lumin U1X (Black) ¥1,331,000



DIGITAL FILE TRANSPORT

•Network Players A younger generation of developers/manufacturing countries in Asia has emerged to develop devices that rely heavily on computers, such as network players. Lumin products are developed in Hong Kong. Since the wooden machine does not have a D/A converter section, it becomes a network transport rather than a network player. The power supply is set to 7. Calm sound with thick bass. (fuu)

Score 7

3rd place Ohlander W20 Special Edition ¥3,150,000



DIGITAL FILE TRANSPORT

•The biggest feature is switching from built-in or external storage to dedicated SSD High-speed copying and playback of sound sources. Abundant digital output too Equipped with a dual AES DAC made by dCS, for example. Possible. The music playback app developed by Hakusha stores storage by IP address. Because it captures images, it is not subject to the restrictions of UPnP or DLNA. Good sound quality Definitely a top class transport. (Noiring)

Score 7



Ranked Rin Klimax DSM/3/H ¥4,800,000



USB/LAN(SFP) compatible

•This is a new flagship model that Lynn completed by reviewing the basic design of from scratch for the first time in 14 years.)" holds the key to sound quality. The sound that energizes the performance and strongly draws the listener is carried over to the new SELEKT DSM, which also incorporates ORGANIK. (Yamanouchi)

Score 8

3rd place, Merging Technologies NADAC Player (8ch) + NADAC Power ¥3,00,000.



USB LAN compatible

•A digital workstation that is useful in music production sites NADAC is a consumer product from a famous manufacturer. With LAN input Roon Core is built into the DAC to become a player. Perhaps following the company's professional equipment, which is mainly multi-channel, this unit has an 8-channel model, and can also combine the output into 2-channel stereo. 7 Beautiful sound that sounds polished. (Shin)

Score 7

7th place Lumin U2 Mini (Black) ¥473,000



録 ★

DIGITAL FILE TRANSPORT

Miura Yamanouchi ★ ★

Score

3

In order to confirm its effectiveness as a "network transport," I compared and listened to the sound directly connected from the music server to the D/A converter and the sound that went through this unit, and wondered, "Is the sound that much different (= better)?" I was surprised and came to a new realization. After listening to the sample, I realized that the role of this unit is to retrain digital signals. The sound quality improvement effect is similar to that of a high-quality preamplifier. (Mayuzumi)

6th place Soul Note Z3 ¥1,060,000



Onodera 録 ★

DIGITAL FILE TRANSPORT

Mayuzumi ★ Yamanouchi ★ ★

points

5

This is a top-of-the-line network transport model that demonstrates its true value through ZERO-LINK connection with the D/A converter D3, and pursues Soul Note's design philosophy without compromise, such as a non-return power supply circuit and non-fixed housing. I get the impression that I can always hear the powerful instantaneous power and high-density sound produced when the phases are aligned with high precision from any sound source, and although the stimulation is strong, it induces a certain kind of comfort. (Yamanouchi)

9th place

Blue Sound Node	OPEN (around ¥85,000)	録 ★ 止之内 ★
リン	Selekt DSMK	¥1,150,000
lead son	Oratorio	¥3,200,000 小野 ★ 博 ★

12th place Chiiet:Angel.MIT. OPEN (around ¥128,000) Fu ★

Position, Son	sMS200 Neo Special Edition (Silver)	¥1,320,000	Miura ★
Specifications	RMP-UB1 SFP	¥330,000	Miura ★
Sphenozato DST-Lepus		¥380,000	Miura ★
Esoteric N03T		¥780,000	12 乃 ★
Kakrason Burdens X45Pro		¥880,000	Miura ★
Ohlander N20		¥1,700,000	within 112 ★
Sforzato DSP-Vela		¥1,800,000	Yamanouchi ★

7th place Merging Technologies NADAC Player (stereo) ×,750,000



録 ★

Miura 提 ★

Score

3

USB LAN compatible

- Uses the same ESS DAC element as the company's professional ADC DAC. This machine has a PC (core) dedicated to Roon. Although you need to use Roon first, you can also connect it to a PC or Mac and play music on Audirvana or JRiver. The biggest appeal is that you can get a sound that closely matches the high-resolution recording site. upgrade You can use an external power supply (sold separately).

[Miura]

First place Western wood U· Bros 280R ¥980,000



Fu Onodera ★ ★ ★ ★

録 ★

提 ★

Score

11

Vacuum tube preamplifiers often have poor sound field. This is the current product that gives off a sense of atmosphere. Thin signal path Blue, dual mono configuration, elaborate L/R independent volume adjustment mechanism It worked. It is a preamplifier that actively affects the music, and it is Colorful overtones dance wildly in the clear, clear sound field 11 ru. The volume adjustment on the remote control is easy to use. (fuu)

BEST BUY COMPONENTS

preamplifier

→ Less than 1 million yen.

3rd place Jeff Rowland Capri SC ¥790,000



Fu Onodera ★★
Milura ★
Yamanouchi ★
score 6

•This is the company's only preamplifier, the current version of the 3rd generation Capri, which has continued to evolve. Compared to the previous model, a larger power supply board has been added to occupy the interior. PSU: Power storage unit. By making extensive use of small but large-capacity supercapacitors, the PSU not only strengthens the power supply, but also provides the effect of battery High S/N (傳) feeling, sounds simple and straight. (operation)

2nd place Accuphase C2450 ¥750,000



Fu ★★
Milura ★★
Yamanouchi ★★
score

•The higher-end model C2850 has already been renewed as the C2900, but the C2450 still occupies an important position in this price range. Like higher-end models, the change in tone depending on the volume position is minimal. The sound doesn't get too thin even at low volumes, so even in environments where you listen at low volumes, the sense of substance and texture is not sacrificed. Basics such as S/N 9 Noh is one of a kind. (Yamanouchi)

5th place Luxman CL38uC ¥390,000



Onodera ★★
Milura ★
Yamanouchi ★
score

•This preamplifier symbolizes one aspect of Luxman's manufacturing spirit: fun to use, fun to look at, and fun to listen to. The circuitry that uses vacuum tubes and the nostalgic, warm design that pays homage to the company's past products are appealing, and it also has a good feel of operation that separates it from products that prioritize being able to do everything with a remote control. sound and appearance 3 different flavors, warm and organic. (Onodera)

4th place Accuphase C2150 ¥500,000



Fu ★
Milura ★
Yamanouchi ★★
score 4

•This is the company's entry-level model, but the resolution is not lost even when the volume is turned down. In addition to the AAVA system, it uses an ANCC circuit that significantly reduces distortion and noise (both patented technologies). Bass/treble tone The functions, including control, are the same as the higher-end model C2450, and it is also convenient to have two slots for option boards such as digital manual input and analog dsk input. It is definitely a high C/P machine. (Ura)

5th place Esoteric CO3XS ¥850,000



Milura ★★
Yamanouchi ★★
score

•Almost all circuits from power transformer to output amplifier left and right. The results of the independent dual-mono design are remarkable. Front, rear, left and right. The most notable features are a clear sound field and excellent separation. So, choosing a wood machine becomes a big problem. More supercapacitors. The instantaneous power and momentum brought about by the stabilized power supply used are also outstanding. one of the advantages of the three scoring machines. (Yamanouchi)

5th place Benchmark LA4 OPEN (around ¥150,000)



Onodera ★★
Milura ★
score 3

•Compact from a company with a background in professional machine development. Preamplifier exclusively for line level. The volume can be adjusted in 256 steps in 0.5dB increments. fixed resistor matrix. The sound image focus is arranged and tightened. It is a small machine that is characterized by a powerful and aggressive sound. rose A headphone amplifier with a THX-AAA circuit that also supports audio output. There is also an added sibling, the HPA4. (Nothing)

9th place	Macintosh C	¥540,000	小・大 ★
	Macintosh C22V	¥50,000 extra large	
	Macintosh C22V	¥830,000	大 ★

8th place pass	XP12	¥840,000	Milura ★★
----------------	------	----------	-----------

First place

Accuphase C3900 ¥2,000,000



Fu Onodera

★★★★★

Miura Yamanouchi

points 11

•An indispensable part of my audio system, which I love listening to every day. Living with a high-quality preamplifier on a daily basis not only allows you to enjoy good sound, but also leads to a sense of satisfaction due to its elegant design and high-quality tactile feel. I was surprised by the evolution from the C3850. When the sound fades away, the reproducibility of the nuances of the lingering sound has been greatly improved, the purity of the sound is high, and you will be surprised at how clearly all sounds resonate. (Mayuzumi)



3rd place

Accuphase C2900 ¥1,400,000



Fu

★★★★★

Miura Yamanouchi

Score 7

•The AAVA of this unit has been upgraded to a balanced configuration. Although it is similar to the dual-balanced C3900, the actual performance difference is at an extremely high level. The sound quality tends to be slightly different between these two models, so you may choose the C2900 after actually listening to the sound. The C2900's characteristics include good dynamic response and strong instantaneous power, giving the performance an outstanding sense of dynamism. (Yamanouchi)

2nd place Soul Note P3 ¥1,600,000



Onodera

★★★★★

★★★★★

Miura

★★★★★

Yamanouchi

points 10

•The attenuator circuit is a switching system using a naked foil fixed resistor without resin molding. This is a dedicated line-level preamplifier with an emphasis on sound quality, including the use of custom products with ultra-low loss for the relays including the input selector. It also features independent left and right control power supply sections, making it the perfect companion for the new monaural amplifier M3. [Miura]

Macintosh C12000 ¥2,300,000



Onodera

★★★★★

points 6

• Features a 2-casing configuration that separates the audio circuit and power & control circuit. Equipped with a tube-type phono equalizer, and has two output systems: solid-state and tube-type. It is characterized by an overwhelming sense of scale, and the solid-state output produces clear, unambiguous sound. The transparency of the space is extremely high. The tube output has a soft sound and is interesting in that it has a rich lingering sound. (Mayuzumi)

3rd place Luxman CL1000 ¥1,800,000



Ono is

★★★★★

★★★★★

Miura

★★★★★

Yamanouchi

Score 7

- Luxman has developed an electronically controlled attenuator in search of a precise and high-quality volume adjustment mechanism, but this unit uses a multi-tap transformer instead of a regular fixed resistor. is the biggest feature. The vacuum tube circuit and transformer are a perfect match, and the sound is fresh, sharp, and has an outstanding texture. The tone control equipment is also nice. [Onodera]

6th place Octave HP700SE ¥2,700,000



Onodera ★
種 ★
Mayuzumi
Yamanouchi ★★
Score 5

•This is a supreme preamplifier that symbolizes Octave's long-standing design approach. To this day, we have maintained the highest level of performance imaginable, including the wide range of optional modules available, and we have earned an unwavering reputation for our high reliability. The reproduced sound highly satisfies the various conditions required of modern preamplifiers, such as the amount of information and response characteristics, and is of a high standard that can also be used as a reference device. (Yamanouchi)

6th place Phasemation CM2200 ¥1,800,000



Onodera ★
種 ★★
Mayuzumi ★
Yamanouchi ★
Score 5

•The brand's parent electronics manufacturing company is a professional transformer company. This unit is a passive unit that uses a volume adjustment circuit using a transformer, and is named "Control Meister." A 6dB switch was added that was not present in the previous work. The difference between a general passive preamplifier and a wooden machine is that it has balanced input and output. Since it is passive, the S/N sensitivity is extremely high. (den)

8th place Macintosh C53 ¥1,000,000



Onodera ★★
種 ★
Mayuzumi
Score 4

•Macintosh has been in a rush of new products lately. Although various types of models have appeared, this is a high-end model with a solid-state preamplifier, and it also strongly conveys the company's tradition. Its great appeal is its versatility, including the inclusion of an 8-band equalizer that is extremely effective in adjusting the tone. The sound is generous and has excellent texture description.4] The sound is satisfying to listen to. (Onodera)

8th place Fundamental LA10 version II ¥1,000,000



Hyakudera ★★
種 ★
Miyata ★
Score 4

•The fundamental appeal is that each product is made with soul, with the designer and developer himself holding the soldering iron, manufacturing the circuit board and assembling the casing. This unit is a preamplifier with a thorough focus on sound quality. So, the power supply was made as strong as possible (hence the separate holiday), and the amplifier circuit was made as simple as possible. A sound full of delicacy that embodies the true taste of music in a pure and straightforward manner. (Onodera)

8th place Technical Brain TBC-Zero/C ¥2,280,000



Onodera ★
den ★
Mayuzumi ★
種 ★
Score 4

•MC dedicated phono equalizer amplifier also available as a standalone unit. Built-in circuit. The simple amplification circuit of 1-stage amplification + emitter follower produces a high-speed, delicate sound with no coloration. Another feature is the high-resolution sound that maintains transparency down to the smallest areas. Inputs are only XLR terminals including phono. Another interesting feature is that it is a complete DC 4 amplifier.

8th place Yamaha C5000 ¥1,000,000



Fu ★
種 ★
Miyata ★
種 ★
Score 4

•It has a sound that gives a sense of elegance, which is common to the exterior design. Feeling of exaggeration
Extremely natural sound with no sense of emphasis
There is also. He doesn't make unpleasant or irritating sounds, but he is a talented player who can reproduce all the sounds you want to hear. I would also like to point out that it is equipped with a high-quality phono equalizer. The S/N sensitivity is excellent, and the sound is full-bodied, typical of analog. (Mayuzumi)

8th place Goldmund Mimesis 375 Nextgen ¥3,200,000



Fu★

Mayuzumi★

★

Yamanouchi★

Score

4

It's a sound that gives you a feeling of blood-flowing warmth that you can't hear anywhere else, and it has a wonderfully soothing sound. The sound of applause and other sounds conveys the gentle feel of Gaku, and the sound is dense and solid, which can only be described as exquisite, but as expected, the edges are not angular. Although it has power, it is dignified without showing off. The female vocals are glossy and have a sexy feel to them. (Mayuzumi)

8th place Pass XP32 ¥2,550,000



Mayuzumi★

三浦★

score

4

A total of 3 cases in which the left and right amplifier circuits are electrically and physically independent is rare in the world. With perfect channel separation, this preamplifier gives you a sense of spaciousness and depth in the sound field, as well as richness in the height direction. The power supply section has three independent systems, including one for the control circuit. The combined power amplifier is a stereo. I definitely recommend a monaural machine rather than an audio machine. (Miura)

15th place Mark Levinson No5206 ¥1,000,000



Onodera★

Mayuzumi★

Yamanouchi★

Score

3

Mark Levinson is a brand that symbolizes high-end audio and has a history spanning half a century. Over the past 50 years, the characteristics of their sound have gone through several changes, but the 500 Series and 5000 Series have created a sound that respects steadfastness, as well as a level of familiarity and warmth never seen before. This unit has grown into a sound equipped with the following, and this unit shows off its characteristics to the fullest. (Onodera)

8th place Esoteric Grandioso C1X ¥3,600,000



Onodera★

傳★

Miura★

Yamanouchi★

score

4

Esoteric's highest grade line is the Grandioso series. This series is characterized by its extremely elaborate design, which at times seems overdone, including the amount of material used, which is what makes it so appealing. This unit has a newly developed balanced attenuator that allows you to precisely adjust the volume in incredibly small steps. For delicacy and massiveness. Strong and powerful sound. (Onodera)

17th place

Macintosh C2700	¥1,140,000	Fu★★★
Luxman C900u	¥1,200,000	Urayamauchi★
octave HP300SE	¥1,280,000	小野★ Fu★
code Ultima Pre2	¥2,900,000	小野★ 傳★
air KX-RTwenty	¥5,200,000	Miura★★★
Ipsicon PST100 mk2 SE	¥8,000,000	小野★ ★★

23rd place Soullion-325 Preamplifier

Bus	¥1,480,000	12 内★
	¥1,500,000	Miura★
Mark Levinson No523	¥1,900,000	Miura★
Blucasten Design M20	¥2,200,000	Yamanouchi★
Mola Mola Wakua Pre-amplifier with i option	¥3,250,000	Dai Miura
Unistominstarus!Quest	¥3,000,000	森★
plumester 088	¥3,000,000	Miura★
Technical plane TBC-Zero EX2 Complete	¥3,980,000	Miura★
Solution 725 Preamplifier	¥5,400,000	小野★
Burmester 077+PSU	¥6,500,000	小野★
三洋電機株式会社 Virgo III	¥6,800,000	Small 傳★
Piritum Alexander	¥7,000,000	Fu★
Goldmund Mimesis 22 H Nextgen	¥9,600,000	森★
CH Precision L10	¥10,000,000	Mayuzumi★

15th place Audio Note M7 Heritage ¥4,565,000 (tax included)



Onodera★

傳★

森★

Score

3

The M7 Heritage is the third generation of the M7. Phono amplifier section (MM Vacuum tubes are used in all amplification stages, as the input only) is also vacuum tube. Instead of using a printed circuit board, we set up posts and manually wired each component. Carefully made. We also use original parts, and what parts are used? They are also of high quality. Elegant and colorful texture and tone with elasticity. Rhythmic sound. (fuu)

First place
 Den Onodera
 punob
 Miura
 Yamanouchi
 points
 11

Esoteric S05 (Silver) ¥900,000



•It was hard to choose between the Accuphase A48 and the Accuphase A48, and although I wanted to give both of them the highest score, I gave the newer model a 3. The sound is vivid, clear, and polished, giving off a beautiful shine. It is also a sound that is lively and full of vitality. ES-LINK analog connection is extremely effective. The minute changes in facial expressions are more clearly reproduced, and the number of high scores increases overwhelmingly. (Mayuzumi)

3rd place
 Onodera
 Miura
 Yamanouchi
 score
 8

First Watt F8 ¥550,000



•It is a simple Class A power amplifier, and although it does not have any distinctive features on the outside, there is no doubting its quality as an amplifier. The moment it makes a sound, you'll be captivated by its quick rise and lightness of movement, and the eloquent expression on its face will make you smile. Recommended for music fans who don't need high output power and prefer a single-ended power amplifier as simple as possible. (Yamanouchi)

5th place
 Miura
 Yamanouchi
 score
 6

Accuphase P4500 ¥550,000



•Output stage is 4 parallel push-pull with 90W + 90W (80) output
 This is a mid-sized AB class power amplifier from the company. The output is It doubles as the impedance increases. damping factor
 -The nominal value is 700. Balance human power positive and negative signals respectively
 Adopts instrumentation amplifier method for highly accurate management
 6 Yes. It is equipped with a humanoid power supply unit and weighs nearly 30kg. (fuu)

2nd place Accuphase A48 ¥750,000



•Although the company has the popular A75, this power amplifier, equipped with a human-shaped heatsink, is a power amplifier that can be compared not only in terms of sound quality but also in the style of the sound. I listened to it in combination with B&W's 8000D3 before. I was very impressed with its ability to drive the low range, which is often difficult to produce. Bridged monaural operation 10 outputs 180W (80). (Miura)

4th place Fundamental MA10V ¥980,000



•The combination of a powerful power supply section and a simple amplifier circuit provides excellent performance.
 This is a typical method for making a power amplifier, but this unit eliminates the negative effects that vibration and mechanical stress have on sound quality.
 7 is achieved by combining a chassis with a well-thought-out structure to achieve a natural feel and agile response. The V-shape makes it more powerful and delicate than the original model, making it even more appealing. (Onodera)

7th place Pliers mark AHB2 CPEN (Y540,000 revised)



Onodera Miura

•Although I don't think it is very well known in Japan, Benchmark is a brand that should be followed closely. I like the very compact and simple appearance, but the sound is also very appealing, with a crisp and crisp sound that makes the speakers sing with a powerful sound that you can't believe their size. The crisp, positive sounds are soothing. (Onodera)

Score 3

6th place Pass XA25 ¥680,000



Miura Yamanouchi

•Single push-pull class A operation using a human-shaped industrial power MOS-FET with screw-fastened terminals. It is the company's smallest power amplifier, and with an output of 25W + 25W (80), there will be few cases where it will be insufficient. It has a simple configuration reminiscent of FirstWatt, but the large power supply section and voltage increasing circuit produce an authentic and high-quality sound typical of the company. There is also a sibling model, the INT25, which has a built-in preamplifier. (Miura)

points 5

8th place	New Prime STA9X	¥220,000	★ 止之内★
	new prime , AMG STA	¥300,000 Small	★ 止之内★
	Luxman MQ88uC	¥420,000	小野★ 傅★
11th place	Audio Design DCPW240	¥500,000	Piss★
	Primer A35.2	¥540,000	小野★

BB power amplifier

COMPONENTS

100-200

Less than 10,000 yen

2nd place Luxman M10X ¥1,500,000



Mori Ono emily

•Although the company's products have a full range of integrated amplifiers, there is also a solid amplifier (also a vacuum tube amplifier), and this unit has a power of 150W + 150W (80) Output. Class A operating range is up to 12W, allowing normal playback sound. If it's a good amount, you can probably listen to it in A class motion. Feedback only distortion components

It has been developed and equipped with the company's original circuit, which produced a vivid sound by scoring. (fuu)

Miura Yamanouchi

1st place Accuphase P7500 ¥1,350,000



Onoko Fu

•I'm completely in love with this power amp. P7500 is. Although it is an improved version of the P7300, the improvement in sound quality is amazing. compare the two. As a result, the P7500 increases the width and depth of the sound field, making the sound image stand out. It can be seen that the physical sensation is expressed more clearly. moreover, Compared to the P7300, the P7500 has an overwhelmingly better sound clarity and 12 "Sense of reality" has also improved significantly. (Miyazaki)

score

3rd place Wooden U· Bros 120R ¥1,180,000 (pair)



Onodera ★★
★★★
★★★
★★★
★★★
points 7

•Uesugi has been focusing on vacuum tube amplifiers for many years, but with a change of designers, they have produced unique products that balance tradition and innovation. This unit is a monaural unit that uses a circtron circuit that allows you to pursue sound quality without being limited by the performance of the output transformer, and its 90 watts of power is plenty for a vacuum tube type. A resilient, clear, and powerful sound. (Onodera)

3rd place Mark Levinson No5302 ¥1,000,000



Eight bodies ★★
★★★
★★★
★★★
★★★
score 7

• Mark Levinson announced an anniversary model to celebrate its 50th anniversary this year, and it can be said that it is a sign of greatness in the content. This machine is present. Although it is relatively compact, the company's traditional high drive ability is of course uncompromising, making it a serious vehicle. It has just the right amount of room to not be too bulky, giving you a feeling of gentleness and good texture. Lots of charm, such as texture. (Onodera)

1st place No. U.Bros 300AHPS ¥1,280,000 (pair)



den ★★
★★★
Miura ★★
score 4

•The company's current amplifiers combine the best of both the mature technology of yesteryear and modern technology. This unit uses a single 300B (manufactured by Pusban), the star direct-heated triode, for class A2 operation, and is equipped with DSP to eliminate the hum that occurs when the filament is ignited with alternating current. 12W (THD:5%) for a 300B Power and big. single

3rd place Accuphase A75 ¥1,300,000



Onodera ★★
Fu ★★
★★★
Miura ★★
★★★
★★★
score 7

•High output of 120W per channel with 40 load is class A. This overture the processed nature of sound, and the power of the sound and the strength of it separately power as determined by numerical values. This is more persuasive than ★★. I have no concerns about driving large speakers. There isn't. The S/N has improved compared to the previous generation, and the instantaneous power of the full and the strength of the crescendo rising from silence or weak notes are outstanding. Score 7 is also a merit worth mentioning. (Yamanouchi)

8th place Yamaha M5000 ¥1,000,000



Myzumi ★★
Miura Yamanouchi ★★
score 4

•Uses Yamaha's patented floating & balance method. The highest quality stereo power amplifier. It is electrically floating with respect to ground, and a total of four pairs of MOS-FETs achieve complete symmetrical push-pull operation. The sound is clear and powerful, with an aesthetic quality typical of Yamaha, and boasts a high level of ability to produce sound from large speakers with

6th place TAD TAD-M1000 ¥1,500,000



Fu ★★
Miura ★★
★★★
★★★
score 4

•Is the evolution of power amplifiers linked to improvements in speaker performance? Manufacturers like TAD, which handles both, have strengths that other companies do not have. M1000 is also from the Evolution series speakers. He is conscious of bringing out his true potential, but of course he has the ability to play other types of games with ease. A vast sound field and a realistic sound image are both perfectly balanced. (Yamanouchi)

8th place Macintosh MC1502 ¥1,800,000



傳 ★

水原

Score

3

●Uses 8 KT88 output tubes (4 channels per channel), which are the same as the classic MC275, achieving an output of 150W x 2. It's full of energy and has a solid sound foundation. It's a sound that will leave you immersed in the satisfaction of "listening to a Macintosh!" The vocals have an exquisite luster, and the string orchestra has an aphrodisiac sound.

(Mayama)

8th place Macintosh MC462 ¥1,430,000



Onodera

★

points

3

●American Macintosh products are available in good quality, and every year I find it difficult to choose which one to buy at Best Buy. If there were no restrictions on the number of models, all of them would be great. The only thing I would like to point out is that the characters and quality are stable. Common characteristics include a dark texture, just the right amount of elasticity, and a unique sense of transparency and power. This unit is a stereo unit that boasts an output of 450 watts, and is not too large and easy to use. (Onodera)

11th place Macintosh, MC312 ¥1,070,000 Fu ★Na★

12th place water cross Duo 125 XD ¥1,500,000 Miura ★
Grandy Note Silva ¥1,650,000 Niura★

BBB
Power Amplifier
BEST BUY
COMPONENTS 2
million
yen or more

2nd place Accuphase A300 ¥2,700,000 (pair)



More Ono envoy

傳 ★

Miura ★

Yamanouchi

125W(80) with 20 parabush output stage. Weight 45kg 10 or more. Deep, well-balanced sound. (fuu)

●Successor to the company's highest grade A-class power amplifier, the A250. The appearance is not much different from the previous version. It is the culmination of the company's power amplifier technology, including a double MCS+ circuit that drives two completely identical circuits in parallel, and an instrumentation amplifier. Supported by a large power supply

1st place Soul Note M3 ¥3,000,000 (pair)



Ono Jusun

傳 ★

Miura ★

Yamanouchi

●Monora, which has appeared in the "3" series, which is the highest grade of Soul Note. power amplifier. A unique product that can be said to be the culmination of the company's products in recent years. This work is packed with the know-how of — It's incredible, but every detail has a sound quality reason. is wonderful. The high level of freshness and speed of reaction are on a different level. Shin 11 Makes you feel the essential goodness of the pull circuit. (Onodera)

4th Macintosh MC3500 ¥4,400,000 (pair)



Den Onodera ★★

Yamanouchi ★

Score 6

•A vacuum tube monaural power amplifier that revives the classic MC3500 (released in 1968) into the modern era, with the same model number. As expected, the vacuum tubes and details used have been revised to reflect modern trends, but perhaps because the basic design has been inherited, it has a rich and rich feel that makes you feel as if you are spending a relaxing and luxurious time, which is rare in modern times. Plays a great sound. Of course, there is no shortage of delicacy. (Onodera)

3rd place Wooden U Bros 330AHWE ¥2,100,000 (pair)



eight-pointed body ★★

津 ★★

Miura ★

Yamanouchi ★

score 9

•The sound of a new frontier of Uesugi. What on earth was it that I had always thought was the "sound of the 300B"? After listening to this amp, I was astonished by the capabilities of the WE (Woostan Electric) 300B, and I was able to use it to perfection. I have a renewed sense of awe at Mr. Nakao Fujiwara's design skills. The sound of the exquisite velvet touch will transport you to the paradise. It's a word that doesn't make you think about the ball, but you can't get enough of it unless it's a ball. (Mayuzumi)

6th place Audio Note Departure ¥3,124,000 (tax included)



Yoshi Onodera ★★

津 ★

Miura ★

Score 4

•The sound of the company's products has an elegant and colorful texture and tone that is attractive, but they are expensive. This is the company's entry-level power amplifier, but at this price. Handmade machine for small quantity production. The internal wiring uses silver wire insulated with silk and high-quality components, and is assembled by hand without the use of printed circuit boards. 32W + 32W (1kHz, THD: 1.5%) with a push-pull connection of EL34. (fuu)

1st Place Burmester 216 ¥4,350,000



Handmade Yoshi ★★

津 ★

JNR ★

score

•Although the successor to the 911Mk3, it has been reborn into a new generation by inheriting the technology and design of the flagship mono amplifier 159. Handling has also improved significantly, with careful attention to temperature control and the ability to produce the best sound in just a few minutes. A clear tone and an aggressive and lively expression are both compatible, and the words are sure to capture the highlights of the performance. Thanks to the powerful power supply section, the quality of the bass instruments is superb. (Yamanouchi)

6th place Mark Levinson ML50 ¥5,500,000 (pair)



Onodera Miura Yamanouchi ★

津 ★★

score 4

•For my generation, Mark Levinson amplifiers have always had a special existence, and the appearance and sound of these masterpieces from generation to generation are still etched in our memories. Not only does the ML50 rekindle that memory with both its sound and appearance, but it also exudes a certain special aura that draws you in. The driving force that makes the speaker sound loud and clear is reliable. [Yamanouchi]

6th place Pass X600.8 ¥3,800,000 (pair)



Fu★

津 ★

score 4

•The MOS-FET output stage supported by a powerful power supply boasts class AB 600W (80), with a peak class A operating range of 100W. I play the Magico M3 at my house, but I'm listening to the same M9 at the importer. Two sets of this machine were in use when I was there. The dynamic, natural-touch sound that doesn't make you tired of listening was designed by Nelson Pass, a legend in the high-end audio world. (Ura)

Speaker System

DD Player

DD Transport

D/A Converter

Digital File Player

Preamplifier

Power Amp

Integrated Amp

AD Player

Phono Cartridge

Phono Amp

Other Component Accessory

9th place Macintosh MC611 ¥2,300,000 (pair)



Onodera

★

Mayuzumi

Score

3

•There are many people who are attracted to the traditional design of Macintosh's solid state power amplifiers. Just looking at the meter, which glows mysteriously in blue, will give you a great sense of satisfaction. Of course, the sound is also good. It's lush and fresh, the music has a wonderful sense of dynamism, the sound has a solid base, and it has a sense of stability that doesn't budge, as if it's rooted in the earth. (Mayuzumi)

New Ultima 5 ¥2,300,000



Onodera

★

score

3

•We asked the company's founder what kind of design he keeps in mind. The answer was Agile regarding power. The company's products use switching power supplies, which are known for their instantaneous power, even in large power amplifiers, in a way that allows them to be used with low noise. The words are not only questionable, but also well-organized with depth and depth. 300W+300W(80). (fuu)

9th place TAD TAD-M700S ¥4,500,000



★

Miura

★

Yamanouchi

points

3

•At the company's factory, a person who has earned the title of "Takumi" is in charge of assembly. Since many of the products are heavy, machines that hold and rotate the products assist in assembly, and the upper stages are inside a clean room. Mechanisms have a lot to do with the sound of an amp, but there is no other model that can be built as thoroughly as a wooden machine. The base is a cast aluminum monocoque chassis, on which a powerful power supply and 175W+175W (80) amplification stage are mounted. (fuu)

Phasemation MA2000 ¥3,000,000 (pair)



Onodera

★

Yamanouchi

★

score

3

•Phasemation's flagship monaural power amplifier. Two popular 300B direct-heated triode tubes are used for the output tubes, but instead of the push-pull operation that generates more power, they are connected in parallel, and the transformer, which is their specialty, is combined with the driver stage. The company's approach is to utilize it for various purposes. Enjoy the feel and taste of a vacuum tube. (Onodera)

28th place Esoteric

Grandioso 51	¥2,000,000	Yamanouchi★
Kaluga Mono Power Amplifier	¥2,300,000 pair tax included	Ura★
Constellation Ordel Stereo 1.0	¥2,500,000	小野★
Classe Delta Mono	¥2,600,000	Niura★
lead son Odeon "with balanced input"	¥2,660,000	小野★
viola Forte II	¥3,700,000 pair	小野★
Odia Nlight Strumento n4 mk II	¥3,700,000	Miura★
bus XA160.8	¥3,800,000(pair)	Miura★
Westminster Lab Rei	¥4,000,000 (pair)	★
Macintosh, MC1.25KW	¥4,700,000(pair)	★
Macintosh MC901	¥5,900,000 (pair)	★
Audig Flight Strumento n8	¥7,800,000(Pair)	Niura★
Yipshan Hyperton	¥12,000,000★	
Pirimu Hercules	¥12,500,000(7 傳)	★

13th place

パス X350.8	¥2,000,000	Miura★★
Fesme Shon MA1500	¥2,000,000:	Haa: Fu★Ura★
Solution 311 Stereo Power Amplifier	¥2,250,000	Oyamauchi★Spec
RPA-MG55T	¥3,850,000	Den★★
Goldmund Telos 440	¥4,400,000:	Pair: Yamauchi★
CH Precision A1.5	¥4,900,000	Oyamauchi★
enteric Grandioso MIX	¥5,200,000:	Pair: 小野★Yamauchi★
エフー MX-RTwenty	¥5,700,000:	Miura★★
Technical Brain TBP-Zero EX (Silver)	¥5,850,000:	Pair 小野★★
Jeff Rolland Model 735	¥6,330,000 pair	Fu★★
Specs RPA-MG1	¥6,600,000 pair	★Miura★
TAD TAD-M700	¥7,500,000:	Paa: Fu Niura★
Ingshan Aelius 2 Mono SE	¥7,800,000:	P: Kodera★ Yamanouchi★
Solution Dan 711 Stereo Power Amplifier	¥7,800,000	Fu★★
D'Agosteto / Momentum M400MxV	¥13,900,000:	Pe: Yamauchi★★

First place Marantz Model 30 ¥298,000



- Den Onodera ★★
- period ★★
- Miura ★★
- Yamanouchi ★★
- Score 12

•This unit, which has Niyamashiro's "Marantz face", is characterized by an elaborate design of the preamplifier circuit that affects sound quality, and the highest quality MUSES72323 volume IC is used for volume adjustment. Also equipped with MCMM compatible phono equalizer. The power amplifier section uses an advanced classro module called NC500 made by Hypex, which produces 200W+200W (40). (Miura)

2nd place Marantz Model 40n ¥260,000



- Den Onodera ★★
- ★
- Miura ★★
- Yamanouchi ★★
- score

•I think the Niyamashiro design that Marantz pioneered is excellent, as it has a sense of openness that frees up the formality of audio equipment. It goes particularly well with new concept products like the Model 40n, which skillfully expresses the value of enjoying music without putting too much effort into it. The comfort of the open sound field and the power of clearly portraying the melody are well balanced. (Yamanouchi)

5th place Denon PMA900HNE ¥120,000.



- Onodera No. ★★
- Miura Yamanouchi ★
- score

•The latest model that fully demonstrates the sound creation capabilities of Denon's audio equipment design. It has a built-in network player function and a digital input, but this suppresses interference and highlights the reliability of the basic design of the analog amplifier. Thorough disassembly of the speaker Scores: Highly efficient, pleasant to listen to, and the digital input sound is excellent. You can enjoy clear sound. (Onodera)

2nd place Denon PMA1700NE ¥199,000



- ★
- ★
- ★
- Miura ★
- LINE ★★
- score

•higher-end machines. A versatile device equipped with DSD11.2MHz, PCM384kHz 32bit compatible USB-DAC, and MM/MC phono equalizer. The power stage is a simple UHC-MOS FET single push-pull circuit, which avoids the muddy sound caused by variations in output. It grips the woofer firmly and has a real feel. Gorgeous words that are worth listening to 9, and I feel that it even has an appeal that surpasses (業)

2nd place Technics SU-G700M2 ¥298,000 (tax included)



- Technics is an enemy ★★
- ★
- ★
- Miura market ★★
- ★
- score

•The company's products are divided into three classes, and this machine is in the middle class. Technology obtained through the development of the SU-R1000, a high-end model that belongs to the de class class. Inherits ★. The wooden machine is a digital amplifier that converts analog signals into digital signals, and is supported by a switching power supply and consists of a PWM-operated output stage. 70W+70W(80). This amp has a high signal-to-noise ratio and a delicate, clear sound. (fuu)

8th place Soul Note A1 ¥190,000



Maruzumi Onodera
★

Miura
★

Score
4

•This is the product that first made me realize the appeal of Soul Note. I couldn't believe the price, and I was surprised by the depth of content and the care that was taken to make it. The sound is also superior to its class, and it stands out in terms of its liveliness, which allows the speaker system to play freely, and its large number of high-pitched speakers. This is the essence of the company's products: simple circuits and powerful power supplies. (Onodera)

6th place Marantz PM6007 ¥75,000



Onodera residence
★

Yamanouchi
★

Score
4

•The company's Jinmen to mid-range machines are popular in the export market. One of the reasons may be that the sound is well-balanced and the sound field is presented in a refreshing manner. It has a fully discrete configuration, is equipped with a D/A converter section enclosed in a shielded box, and has MM phono power, so it can be used in a wide range of ways. 45W+45W (80): A great entry-level machine. (fuu)

8th place Yamaha A-51200 ¥260,000 Ono★

BEST
Integrated amplifier
COMPONENTS
Less than
300,000-800,000 yen

2nd place Luxman L507Z ¥630,000



onodera book
★

Maruzumi

Yamanouchi
★

Score
9

★•The model number is located in the Luxman lineup. This model is one of the best among the company's excellent integrated amplifiers. A masterpiece model that shines brightly. New amplifier circuit LIFES as pre-main It is characterized by the fact that it was installed for the first time, but above all it has a pure and enjoyable sound. I want to praise the goodness of The phono equalizer sounds good and I can listen to music. Let's enjoy the joy to the fullest. (Onodera)

1st place Accuphase E4000 ¥630,000



Kojo Ono
★

★

Miura Yamanouchi
★

points
12

•The development power that Accuphase puts into integrated amplifiers shows no signs of slowing down. They introduced powerful models in quick succession, the E800 and the E5000, and built on this momentum by completing the E4000. The result of introducing a design method with a separate amplifier in mind is the high dynamic resolution, clear sound field, and profound silence. (Yamanouchi)

- Speaker System
- DD Player
- DD Transport
- D/A Converter
- Digital File Player
- Preamplifier
- Power Amp
- Integrated Amp
- AD Player
- Phono Cartridge
- Phono Amp
- Other Component Accessory

3rd place Yamaha A-53200 ¥670,000



Den Onodera ★★
 puru ★★
 Miura ★
 Yamanouchi ★
 Score 8

●Yamaha's amplifier design is unique, beautiful, and unparalleled. The sound is light, similar to the design, and gives a sense of cleanliness. He is good at reproducing subtle nuances, not overpowering trends. It's nice that it feels moist and moisturizing. In orchestral pieces, you will be surprised at how many different nuances are included in the glossy sound. (Mayuzumi)

3rd place Marantz PM12 OSE ¥350,000



心音 ★
 神 ★★
 雅 ★
 Ura ★
 区 ★
 score 8

●The parent model of this machine was born out of a product plan that cut the cost of an existing high-end machine and made it half the price. The aluminum top plate and copper plating of the chassis, which the designers had given up on because it was impossible to increase the quantity, were able to be used in this OSE version. The effect is great because it is a well-organized amp. Pleasant sound Copper plating provides an expanded sense of space, high S/N, and clear sound. 100W+100W(80) with high efficiency power section. (傳)

6th place Accuphase E280 ¥360,000



den ★
 雅 ★★
 Miura ★
 Yamanouchi ★
 Score 5

●It is a successor of Accuphase's integrated amplifier, and is a model change of the E270, but the purity of the sound has been improved and the sound feels more familiar. It's also a vivid sound, and it emits a sound that can be described as "eye-opening." The sound has momentum. Perhaps because they were developed at a similar time, I feel that the C3900 preamplifier has the same direction of improving sound quality. (Mayuzumi)

5th place Soul Note A2 ¥550,000



Hachinodera ★★
 Mayuzumi ★
 神 ★
 雅 with ★
 score 6

●For details on the features and characteristics of Soul Note products, please refer to other models. As mentioned above, this machine is also an excellent machine that was created with the same design concept and has a large number of sounds. Although it takes the form of an integrated amplifier, it has an outstanding speaker drive ability that makes you want to call it a separate amplifier (power amplifier). It is powerful enough to stand on its own. (Onodera)

8th place Denon PMA-SX11 ¥420,000



神 ★★
 雅 ★★
 score 3

●The circuit configuration of the company's recent products has changed, but this machine is The sound of analog attenuator + high gain power amplifier is vivid. A concise structure that thoroughly pursues sensitivity. Advanced machine PMA-SX1 Limited Unlike, it is dedicated to single-end drive rather than balance drive. It is also a feature that there are Phono equalizer circuit compatible with MC/MM It's true, I like the sound of this unit. [Ura]

7th place JBL SA750 ¥350,000



field ★
 守 ★
 Mayuzumi ★
 区 ★
 score 4

SA750 is complete. SA750WAL (380,000 yen) on sale from December 2022 ●Oma to JBL's classic integrated amplifier SA600 Written by Ju. Even though it's based on an existing amp, it still has the "JBL sound" as expected. A sound full of dynamism comes out. This is a sound that can only be achieved by JBL. Streaming playback is also possible, and its multifunctional features include a phono equalizer compatible with MC and MM cartridges. (Mayuzumi)

10th

Cam	SA30	¥300,000	Vegetables★★
Denon	PMA-A110	¥358,000	Fu★★
Accuphase	E380	¥180,000	小塚★ Fu★
triode	Evolution	¥500,000	Miura Yamanouchi★
marantz	PM10	¥600,000	止之身★★

15th place

	Buion Scorpio II	¥680,000 L★	
--	-------------------------	-------------	--

8th place Spec RSA-BW1 ¥550,000



傳★

織★

Miura★

Score

3

•His specs have the aspect of being a master of wood, and he has outstanding ability in electronics technology, such as by using a PWM class D analog power amplifier. By harmonizing these elements, the company's amplifiers create a unique sonic appeal. It is a sophisticated modern sound that clearly reproduces the rich expressions of music, and is also outstanding in its luster. (Mayuzumi)

First place

Accuphase E5000 ¥950,000



Fu Onodera★
★

織★
★

Miura Yamanouchi★
★
★
★

score

13

•A top-of-the-line machine that condenses the company's high-quality sound technology of preamplifier and power amplifier into one human-shaped body. This is the 4th edition of the 50th anniversary model, and while it has the dignity of being the ultimate integrated amplifier, it also has the same sound quality as its predecessor.

Large speakers such as the B&W 801D4 can be heard confidently, and the overall high S/N and high resolution sound is a major feature. (Miura)



3rd place

Octave V70 ClassA ¥2,000,000



傳★

織★

Miura★

Yamanouchi★
★

Score

6

•While maintaining the design philosophy inherited since our founding, Octave is also enthusiastic about new design approaches. At first glance, this may seem like a contradictory stance, but it can also be said to be an advantage unique to a manufacturer that aims to evolve shell tube amplifiers using cutting-edge technology. This unit, which combines A-class operation and high output, is at its true potential, and its charm is condensed in its lively yet smooth sound. (Kawanouchi)

2nd place Macintosh MA9500 ¥1,740,000



Kojo Ono★
★
★

織★

Miura Yamanouchi★

Yamanouchi★
★

score

10

•The company's highest quality solid-state integrated amplifier. For example The power output is powered by a unique method equipped with an autoformer. - Adopts amplifier section, 300W + 300W at any impedance Yamanaki. It seems to be made by the same company as it is equipped with an 8-band equalizer. In addition, it is an American product that has a built-in D/A converter as an essential function.

It seems to be made by Rika. Powerful and edgy sound. (fuu)

5th place Fundamental PA10 ¥1,200,000



Onodera ★★★★★
Miura ★
points 5

•The company's first integrated amplifier was a great product, as if it had combined the best features of its predecessor, the high-end separate model. The two-chassis configuration with the power supply section in a separate housing is unusual for an integrated system, but I think it's compact and has a nice design. What's most wonderful is the deeply moving sound that speaks directly to your heart. It must be a solitary existence. (Onodera)

3rd place Macintosh, MA12000 ¥2,000,000.



Shinichi ★★★★★
Fu ★★★★★
Miura ★★★★★
Score 6

•This year, three models of Macintosh's integrated amplifiers have been updated, but this top-of-the-line model has the perfect balance between sound and price, making it the best value for money. There is also a separate type that is about the same price, but I think this one has better sound since it is newer in development. This sound brings to mind the word "fertility." It's moist and glossy. The design is luxurious and you can enjoy the joy of owning it. (Mayuzumi)

Technics SU-R1000 ¥830,000



Mayuzumi ★★★★★
Onodera ★★★★★
Miura ★★★★★
Yamanouchi ★★★★★
points 4

•Technics' original full digital amplifier. In addition to the abundant input and digital correction technology, I highly value the company's proactive approach to utilizing digital correction for analog disc playback. Using a dedicated calibration LP flattens the frequency response and reduces crosstalk, allowing you to hear fresh sounds that were impossible in the analog domain. [Miura]

5th place Debibure Expert 1000 Pro Dual ¥4,300,000 (pair).



Shinichi ★★★★★
Fu ★★★★★
Mayuzumi ★★★★★
Ura ★★★★★
Score 6

•If there is a framework called an integrated amplifier, this product is a super integrated amplifier that far exceeds that framework. Unique technology that combines digital and analog enables various devices to be Full of Noh in a thin body. There is an overwhelming drive power that makes you wonder where it is hidden behind her slim figure, but the best part is how it is displayed in an elegant and aromatic manner. (Onodera)

9th place Denon PMA-SX1 Limited ¥820,000



Den ★★★★★
Shinichi ★★★★★
Ura ★★★★★
score 3

•Current sound master Shinichi Yamauchi has been using the highest quality machine SX1 for 4 years. A special integrated amplifier that has been tuned over many years. It has a configuration that combines an analog attenuator and a high-gain power amplifier, and also features a balanced drive with two UHC-MOS single push-pull amplifiers connected in a bridge. The sound field has also been expanded through the use of custom elements. [Ura]

7th place Accuphase E800 ¥1,030,000.



Fu ★★★★★
Mayuzumi ★★★★★
Ura ★★★★★
score 4

•If you consider the heat generated by the 50W x 2 power amplifier section in Class A operation, this I have to agree with the size of the figure. The sound is an integrated amplifier It is beyond the scope of. The overwhelming quality of SN is impressive, and the sound Silence dominates the space. The three-dimensional effect of the sound image is also wonderful. The drive ability of the speakers is impressive, and I was amazed at their ability to make the B&W 800D3 sound so effortless. (Mayuzumi)

9th place Pass INT25 ¥1,000,000



Onodera
Miura

●I think one of the characteristics of Pass products is that they are powerful, like a dam full of water, but on the other hand, they also have a lineup of products like this machine that are small in output and have great taste, so they have a lot of depth. . It combines the agile simplicity of the company's sister brand, First Watt, with the energy of mainstream Pass, and the textures that create a natural texture are also attractive. (Onodera)

Score
3

9th place Luxman L595A Limited ¥980,000



傳
★
Yamanouchi

●30 years is not a long time for a long-established brand. It can be clearly traced as a passing point in history, and the memory of this monumental model will probably never fade. This limited-edition wooden model with a design inspired by the L570 has a nostalgic exterior, but the Miya is not retro, but has a freshness befitting a modern amplifier. (Yamanouchi)

score
3

12th place	Luxman L509X	¥830,000	Oyamanouchi★
	Macintosh MA8950	¥1,200,000	Oyamanouchi★
	Holborn Passion	¥1,600,000	Fuyamanouchi★
	Mark Levinson No585.5	¥1,800,000	Miura★★
16th place	Audia Flight ELS9	¥1,060,000	小野★
	Aion Triton Evo	¥1,750,000	Niura★
	Ipsicon Phaethon	¥3,200,000	菜★



2nd place Technics SL1000R ¥1,600,000



Onodera
★

- Technics' highest grade printer that also serves as a reference machine for this magazine. Layer. The SP10R turntable is also statically balanced. The high-sensitivity tonearm also has excellent performance and sound quality, so you can use it with confidence. I can. In our sister magazine "Tube Hikuni" Used with the arm and arm base added. Motor torque setting. Subtle changes in sound quality can be obtained with constant settings. (Ura)

Score
7

1st place Luxman PD191A ¥900,000



Onodera
Dai
★
★
★
★

●New analog player products are being announced one after another from all over the world. I'm very happy to be a record player, but I don't think I actually love records. When it comes to models that value-people's feelings, this is surprisingly rare. do not have. This unit is equipped with a completely newly developed tone arm to improve the sound quality. The player who raised it. Enjoy the musical time of playing records. The best thing about it is that it creates a great atmosphere. (Onodera)

score
10

- Speaker System
- DD Player
- DD Transport
- D/A Converter
- Digital File Player
- Preamplifier
- Power Amp
- Integrated Amp
- AD Player
- Phono Cartridge
- Phono Amp
- Other Component Accessory

4th Luxman PD151 Mark II ¥358,000



Onodera ★★
No. ★★
Yamanouchi ★
Score 5

•When you listen to a direct comparison with the previous work, you will be surprised at the improvement in sound quality. The "miscellaneous taste" that clings to the sound has been thoroughly washed away, and the sound has been reborn with a high degree of freshness. There is no doubt that the tone arm, which uses SAEC's knife-edge technology, has greatly contributed to this improvement in sound quality. However, it is true that the high sound quality of the model was made possible because of its high basic performance as a player. new

4th Valtele MG1 PKG MK2 CL ¥1,650,000



Onodera No. ★★
Yamanouchi ★★
points 5

•This is Valtele's core model, which improves the performance of the entire player system by combining it with the latest tone arm, and the power supply section has also been updated to the latest motor drive. The Valtele's greatest strength is that it allows the sound to spread outward and actively bring out the momentum and exhilaration of the performance, and its ability to revitalize the music engraved on a record is tremendous. (Yamanouchi)

7th place Valtele SG1 PKG ¥4,800,000



Onodera ★★
Yamanouchi ★★
score 4

•The elaborate and unique structure is the result of thorough vibration countermeasures, and is an attempt to extract as much music as possible from the grooves of the record. This idea is thoroughly applied to the company's products, and the results of this philosophy are more than evident in the wooden machines, which provide a refreshing feel and a satisfying after-listening experience. It is a dynamic fusion of high clarity and high density. [Onodera]

3rd place Tekdas Air Forcell Premium (armless) ¥3,000,000



Yamanouchi ★★
Miura ★★
LINR ★
score

•It's expensive in absolute terms, but if you consider the performance you get and the satisfaction you get from using it every day, you won't find a better value player. The quietness and stability of the playback sound, which is freed from the negative effects of sledding due to record adsorption, is a world of bliss that only those who have experienced it can understand. The suspension foot version has a better sound, so we recommend that users of the 6-foot suspension model replace it with the new version. (Mayuzumi)

4th Tekdas Air Force V Premium (armless) ¥1,400,000



Yamanouchi ★★
Miura ★★
LINR ★
5

•Air Force's brother uses compactness as its best weapon, and has a sturdy aluminum machined casing with suction inherited from higher-end machines. & Air Floating combined to achieve rock-solid analog playback. The playback sound, which is freed from trembling on the board, has an outstanding sense of stability, and the sound image localization is also very clear. A worldview of sound unique to Techdas (Miura)

7th place Lin Selekt LP12 ¥1,775,000



Yamanouchi ★★
Miura ★★
LINR ★
score 4

•"Selekt!" has become a highly balanced sound quality, usability, and price. It has grown into a great player that is a joy to own. In particular, the new tone arm and cartridge greatly contribute to high sound quality. The sound field feels vast and the freshness of the sound has improved even more. You can feel the skill and spirit of the master performer, and enjoy the charm of analog music. (Mayuzumi)

9th place Yamaha GT5000 ¥750,000



★
Miura Yamanouchi
Score 3

•It is a player that is reminiscent of the GT2000 series, which is a masterpiece from the past, but it has new design concepts unique to wood machines, such as a belt drive that rotates the 7.2 kg platter non-servo and a unique pure straight tone arm. Based on. It is also equipped with a balanced output terminal, and when combined with a large wood cabinet, it produces a magnificent yet delicate sound. (Miura)

9th place Technics SL1500C ¥100,000



★
Miura
Score 3

•A complete system with an elegant design. Not only does it come with a phono cartridge, but it also has a built-in equalizer, so you can enjoy records to the fullest by simply connecting it to an amplifier. There are an increasing number of products that are cheaper than this unit, but this unit is probably the best cost performance in terms of its wood-like analog sound. High performance that responds sensitively to adjustments. (Onodera)

9th place Roxane Xerxes 20 RPM+Sara ¥1,300,000 (Set)



★
Onodera
Miura
Yamanouchi
Score 3

•Roxane's Xaxys was a revolutionary analog player. This model was introduced at a time when analog was in decline, and is etched in my memory as a product that opened up new possibilities for records. The wooden machine has been steadily improved since the original machine, increasing its stability (the debut model was really difficult to adjust due to my nerves), and it produces a pleasant sound with frightening (Onodera) agility. produces a

9th place Rin Majik LP12 SE ¥850,000



★
Onodera
Miura
Score 3

•SE is the higher specification of Majik LP12 with a new tone arm, strengthened power supply and bottom plate, and MC cartridge Koil. Majik is equivalent to the entry level in the LP12 series, but the advantage of purchasing it with the first stage of upgrades completed is significant, and the price is also relatively cheap. Ideal for those who want a higher-grade LP12 from the beginning. (Yamanouchi)



13th place	Technics SL1200G	¥330,000	Miura Yamauchi★
	Elak Miracord 80	¥360,000	Oyamauchi★
	Mark Levinson No5105	¥700,000	★Miura★
	SME Model 6 Classic	¥1,450,000	Niura Yamauchi★
	SLSL Motus II DQ+Vertex Y1,800,000		★Miura★
	Klimax LP12	¥3,565,000k	Oyamauchi★
	enteric Grandioso T1	¥7,000,000	★Miura★
20th place	Planar 3 mk2 with Ely2	¥13,000 (tax included)	
	Miura★ Planar 10 with Apheta 3	¥900,000	★
	blinkman Bardq Performance Armless)	¥1,250,000 discount	★
	Hans Dantry Six, T60SE (armless)	¥1,480,000	Miura★
	oracle Delphi MkVI Gen2 Armless)	¥1,800,000 discount	★
	plinkman Taurus-Tonarm 12.1 R	¥3,490,000	(Sed Miura★)

2nd place DS Audio DS003 Cartridge ¥275,000



- Third generation of the company's optical cartridge
Standard model that uses construction. It combines an aluminum alloy cantilever with a line contact needle, and uses a beryllium shielding plate with the same shape as the Grandmaster.

Score 5 Channel separation is also good, and the optical cartridge's characteristics are fully demonstrated. (Ura)

Onodera ★★★ 2★ Yamanouchi★

1st place DS Audio DS-W3 Cartridge ¥450,000



● Even if you admire the antique quality of the "third generation" optical cartridge, the Grandmaster One is extremely expensive. A custom made product that meets the expectations of users who want a product at a more realistic price. Compared to the previous model DS-W2, there are even more subtle changes in facial expressions.

Score 7 things can be heard clearly and clearly, with excellent sound clarity and resolution. (Mayuzumi)
Sound that comes close to that of a top-of-the-line machine.

Onodera ★★★ Ni★Nouchi★

2nd place Phasemation PP2000 ¥550,000



● Even with the advent of advanced diamond cantilever machines, the appeal of wooden machines remains unchanged. The MC type cartridge's position as a high standard is solid. It has high resolution, good S/N, and ultra-wide range sound, and its ability to depict

Score 5 front and rear perspectives is astounding. The stable sound allows you to immerse yourself in the music with peace of mind. (Mayuzumi)

★★★Miura★ 上之太★★

2nd place Fidelix MC-F1000 ¥100,000



● MC type phono cartridge that uses so-called direct power generation, with left and right coils placed above the stylus. The coil shape, which resembles a baseball home plate, is highly rigid and does not require a winding frame. The sound is far from the air core type.

Score 5 He creates music using an incredibly vivid and overwhelming number of notes. A masterpiece that I would like to call a monument of air core type. (Miura)

Onodera★★ Sanshu★★★

6th place Luxman LMC5 ¥240,000



● It's been a long time since I last played Luxman. This is a new phono cartridge, and its workmanship is excellent and doesn't feel blank. The MC type uses an aluminum cantilever and has an orthodox power generation mechanism, and features a semi-naked body

Score 4 designed with sound quality in mind. The tonal quality is the best of its time, and the reasonable texture is also the best. (Onodera)

Onodera ★★★ Inside★

2nd place Phasemation PP5000 ¥1,350,000



● This is a masterpiece created by focusing on the combination of a diamond cantilever and a natural diamond stylus tip, and by improving the damper and magnetic circuit to maximize the advantages of the diamond material. The moment I

score heard the first note, I was stunned by the speed and freshness of the sound, which I had never heard before. (Kawanouchi)

★★★Nimanouchi★★★

6th place My Sonic Signature Platinum ¥750,000



● Experience as a cartridge designer Mr. Yoshino Matsudaira's rich masterpiece. The high efficiency of outputting 0.5mV with an internal impedance of 1.40 is due to the magnetic circuit using the unique magnetic winding frame SH-X and N50 neodymium

score magnet. The solid boron cantilever provides a sharp response and a calm, low center of gravity, allowing you to hear the depth of music. (Miura)

Onodera★ Miura★★ Yamanouchi★

6th place Audio Technica AT-ART20 ¥300,000



-Cannot be expressed unless it is an air-centered type
Aim for delicate texture with iron core type
An ambitious work but based on the challenge of solving this problem (Power)
From a sound that combines strength and clarity. The results of repeated efforts toward that goal are clearly visible. The titanium body,

score finished using advanced cutting and polishing techniques, also contributes to improved sound quality. (Yamanouchi)

Onodera★★ Yamanouchi★★

9th place Platanus 3.05 ¥350,000



● Debut work 2.05 and second work Developed based on knowledge gained from 3.5S
This machine was the one that was aluminum alloy
Gold hollow tapered cantilever
One is excellent in following the sound. It produces a well-balanced sound that

Score is light and dynamic. The iron core type engine uses N45 neodymium magnets and has an output voltage of 0.4mV. (Ura)

Onodera★ Miura★ Yamanouchi★

9 pieces Denon DL-A110 ¥69,000



-Denon's DL103 is from the 1960s
It was developed for broadcasting stations in
It has also gained popularity among consumers due to its outstanding stability and reliability. If you're a veteran, you've probably heard it at least once. This product, commemorating the 110th anniversary of the

score company's founding, is a product that houses the DL103 in a special shell, and has the charm of a solid sound that does not require too much bandwidth and a richness of expression. (Onodera)

Onodera★★ Yamanouchi★

Phono Cartridge

9th place Audio Note 10-X ¥797,000 (tax included)



•The first model was released in 1979, and this model has improved rigidity and refined details. Masaki Ashizawa, the company's representative.

winds the sterling silver wire power generation coil. Constructed from carefully selected materials with careful consideration for sound

quality, including the use of alnico magnets and palladium-plated pure silver score output pins.

The internal impedance is low at 10 and the output is 0.12mV.

(Ura) Onodera ★★ 2★

9th place Valtere Mystic MC ¥450,000



•Although Valtere is attracting attention for its analog players, they also have an excellent lineup of cartridges. This machine is a model with an orthodox MC type power generation mechanism housed in an aluminum body. The use of an aluminum cantilever and oval

Score 3 stylus improves compatibility with a variety of records, producing a delicate, powerful,

and wonderful sound without making you nervous. (Onodera)

Onodera★★ Yamanouchi★

9th place DS Audio Grand Master Cartridge ¥1,200,000



•It is the latest 3rd generation construction with increased output, and is the first to use a diamond round bar cantilever, making it the pinnacle of optical cartridges. The channel separation is excellent, and the high-quality sound that makes you think that

Score 3 the amplitude carved into the groove is converted into an electrical signal

with great fidelity is appealing. (Miura)

★★Miura★ 止之乃★

9th place Ortofon MC Diamond ¥1,180,000



•It is eye-catching that it uses a unique damper material optimized for diamond cantilevers, resulting in a higher level of playback sound. In addition to the sharp graininess that takes advantage of the speed of sound. At the same time, it has also acquired a

Score 3 richly textured and smooth tone, making it difficult to evolve compared to

previous flagships. (Yamanouchi)

Inside the Miura mouth★★

22nd place	Audio Technica VM530FN	¥23,000	★
	Audio Technica VM750SH	¥50,000	Ono 止之乃★
	Denon DL103R	¥50,000	止之乃★
	ortofon SPU#1S	¥68,000	Ono 止之乃★
	ds audio DS-E1 Cartridge	¥100,000	止之乃★
	ortofon ZM Black LVB250	¥122,000	Sanyu ★
	Mutech RM-KAGAYAKI	¥250,000	一浦★
	Furmaton PP500	¥300,000	Ono 止之乃★
	mysonic Eminent GL	¥350,000	Miura★
	Analog) Lux EX500	¥480,000	Sanyu★
	Rin Kendo	¥480,000	止之乃★
	Yuksan Shiraz	¥550,000	止之乃★
	Audio Technica AT-ART1000	¥598,000	Nimas★
	mysonic Signature Gold	¥650,000	Miura★
	ortofon MC Verismo	¥800,000	止之乃★

15th place	Phasemation PP200	¥110,000	★Miura★
	audio-Technica AT-ART9XA	¥150,000	小野止之乃★ 止之乃★
	EMT HSD006	¥100,000	小野止之乃★★
	EMT TSD MRB	¥240,000	Nai ★★
	Ikeda Ikeda Amane	¥150,000	小野止之乃★Ura★
	Ikeda Akiko	¥777,000	Miura★★
	Techdas TDC01TI	¥850,000	止之乃★ 止之乃★

First place Accuphase C47 ¥650,000



•Do not cause dissatisfaction even with low output air core MC type phono cartridge. It achieves an amazing S/N feeling. Balanced for MC type Fully balanced phono amplification from input to output.

The circuit is the company's first. The high-quality sound is characterized by a timeless quality.

Score 7 The gold-plated "glass cloth foot" used in other flagship machines

I think the contribution of the "resin board" is also impressive.

(Ura)

Onodera ★
止之乃 ★
Miura ★
Yamanouchi ★
Score 7



3rd place DS Audio DS-W3 Equalizer ¥850,000



Score 6
Miura
Yamanouchi

•Although it cannot be used with the MMC type as it is an equalizer made specifically for optical cartridges by the same company, the design with a particularly well-developed power supply section has been successful in achieving high sound quality with solid support. The noise floor is also kept low, allowing you to enjoy the wood-like sound that takes advantage of the advantages of fire and cartridges. Setting the low frequency cutoff to 50Hz is more compliant with the RIAA curve.

(Miura)

5th place Phasemation EA320 ¥270,000



Score 5
Onodera No.
Yamanouchi

•Phasemation loves vacuum tubes, but this machine is a semiconductor type. However, it is an excellent model with a good tone that is unique to the company. The MC/MM compatible non-feedback circuit (that is, the equalizer is CR type) is housed in an easy-to-use compact package, and the EQ curve (3 types) switching function is also nice. The appealing point is the energetic, bouncy, easy-going sound.

(Onodera)

7th place Soul Note E2 ¥590,000



Score 4
Miura
Yamanouchi

•Once you have decided on a Soul Note product, you will move forward without compromise. However, the large number of equalizer curve options on this unit its characteristics are well expressed. Furthermore, it is also compatible with cartridges. The functionality is outstanding. Of course, the basic amplifier power supply section There was no way he could have missed a beat, and it was as if he had shined his light on every corner of the music. The outstanding amount of information is appealing.

(Onodera)

First place Western wood U· Bros 220R ¥650,000



Score 7
Miura
Yamanouchi

•Tube type phono EQ compatible with DS Audio optical cartridge. While the sounds of the various MC cartridges I heard with this unit were excellent, I was overwhelmed by the combination with the DS Grandmaster. The spirit that the musicians put into their sound is beautifully reproduced. Vikaru, full of moisture and vitality, can only be enjoyed using a wooden machine. This sound would only be possible with vacuum tubes, and only with new Japanese wood. (Mayuzumi)

3rd place EMT EMT128 ¥1,400,000



Score
Miura
Upper four

•An attractive product full of precision, with a thin, highly rigid metal chassis and a built-in equalizer circuit using ultra-compact subminiature tubes (vacuum tubes). Equalizer for MC cartridges Easy to use with curve switching (2 types) and mono mode. With a rich sound that combines crisp precision and a sense of openness, you can enjoy the charm of analog that has a pleasant feel to the touch.

(Onodera)

5th place Technical plane TEQ-Zero/s ¥980,000



Score 5
Miura
Yamanouchi

•The amplitude of the sound extracted by the MC type phono cartridge is unrivaled in accuracy. Transparent effect that converts into music information. It seems like the impurities have been filtered out. The sound of the wooden machine that gives the impression of pure water is produced by the company's Purian. The image is similar to that of a pump or a power amplifier. It is a dedicated MC type machine that has an excellent S/N feeling due to the full balance of human and mountain power, and is also suitable for air core types with low output voltage.

(Ura)

9th place DS Audio DS003 Equalizer ¥275,000



Yamanouchi ★
Onodera ★
Miura ★
Yamanouchi ★
 Score 3
 •An optical-specific EQ developed to support the evolution of DS Audio optical cartridges to the "third generation." Compared to the previous model DS002, the thickness of the printed circuit board was changed from 1.6 mm to 2.0 mm, and the copper foil pattern was changed from 35 μm to 70 μm, resulting in a significant improvement in sound quality. The low-pass filter has also been increased from the previous two types to four types. The panel design is reminiscent of the Grand Master, adding to the sense of luxury. (Mayuzumi)

Phasemation EA1200 ¥1,200,000



Onodera ★
Miura ★
Yamanouchi ★
 points 4
 •An improved model of EA1000 that takes advantage of the results of EA2000 development. Packed with phasemation transformer technology and tube-type phono equalizer development know-how. The depth and spread of the sound field are exceptionally good, the S/N is excellent, and the background feels extremely quiet. Resolution and resolving power have improved across the band, giving the sound a new appeal. It's a vivid sound. (Mayuzumi)

9th place Boulder 508 ¥788,000



Mayuzumi ★
Onodera ★
Yamanouchi ★
 Score 3
 •I prefer compact products if possible, and this seems to be especially true for phono amplifiers. This model is a perfect fit for my tastes, and I am in love with its sophisticated style. Of course, not only the style but also the sound is precise, high quality and very attractive. The input and output terminals are for balanced use only, but can also be used with unbalanced connections. (Onodera)

9th place Ortofon EQA2000 ¥540,000



Yamanouchi ★
Onodera ★
Miura ★
Yamanouchi ★
 Score 3
 -Basically paired with Ortofon's high-grade cartridge. Although it is assumed that two independent step-up transformers are used. By separating them, you can extract the true value from a variety of MC cartridges and maintain stability. The band balance and variety of tonal expressions are noteworthy. It offers convenience to listeners who regularly use multiple cartridges in their systems. There are also great benefits. (Yamanouchi)

19th place DS Audio DS-E1 Equalizer ¥100,000 Yamanouchi★

To Bright R15	¥200,000	小野★
oracle PH200 MK3	¥330,000	小野★
divas Model 1	¥1,000,000	Niura★
EMM Lab DS-EQ1	¥1,300,000	Miura★
Jeff Rolland Conductor	¥1,680,000	Small★
XP27	¥1,700,000	Miura★
Brinkman Edison MK II	¥1,730,000	Kodera★
CH Precision P1	¥4,000,000	Yamanouchi★
DS Audio Grand Master Equalizer	¥4,000,000★	
Goldmund Mimesis PH3.8 Nextgen	¥4,200,000	points★
Consplayson Audi Andromeda	¥4,400,000	小野★

12th Triode Hegel

TRX-EQ7	¥55,000	Miura★ Yamauchi★
V10	¥180,000★	Ura★
Rin Urika II	¥550,000	Yamauchi★★
Ragula Classic Phono	¥2,713,000	★Miura★
Phasemation EA2000	¥3,300,000	Miura Yamauchi★
HSE Switzerland Referenceline 7	¥4,300,000	Yamauchi★
epsilon VP5100SE	¥5,800,000	小野★ 小野★

Other components

2nd place Silent Angel Z1 (SSD 1TB) OPEN (around 373,000)



Fu
Mayuzumi
Onodera
Niura

•A network music server housed in an aluminum chassis that looks like a Mac mini, with no fan or built-in DAC. Users can optimize the operation of their own OS, ViOS, and combine sounds. Become a Roon core. This unit has better sound than using 1TB of storage.

Score: 7 It has a low noise design and has a high S/N feeling. (fuu)

First place

DELA N1-538-J ¥1,200,000



Onodera
Fu
Mayuzumi
Niura
Yamanouchi

•Music servers are supposed to be composed of digital circuits from entrance to exit, but analog audio methods such as changing to a linear power supply and increasing the rigidity of the housing can change the sound and improve the sound quality. I know. DELA's design team, who is well aware of this fact, boldly takes on the challenge and extracts a bottomless amount of information.

Score: 8 Completed a new flagship. (Yamanouchi)

brand	Model name	Genre	price	Onodera	Fu De	Niura	Yamanouchi	score
3 DELA	N50-S20-J	NAS(SSD 2TB)	¥250,000		***		**	5
Tainco Audio	SGM Extreme	NAS/MUSIC SERVER	¥5,260,000	*	**	*	*	5
5 DELA	S100/2-C-J	SWITCHING HUB	¥168,000 (tax included)	*	*	**		4
Stax	SR-X9000	HEADPHONE	¥630,000			***	*	4
accuphase	DG68	DIGITAL EQUALIZER	¥890,000		*		**	4
Sakoku	WE4700	TONEARM	¥1,190,000	*	*		**	4
9 Phasemation	T550	MC TRANS	¥110,000		*		*	3
rune	Nucleus Rev.B	ROON SERVER	¥278,000		**		*	3
soul note	X3	MASTER CLOCK GENERATOR	¥350,000			**	*	3
phasemation	T2000	MC TRANS	¥990,000(pair)		*	*	*	3
13 Fursmation	T320	MC TRANS	¥60,000*		*			2
Technics	SA-C600	NETWORK CD RECIEVER	¥100,000	*	*			2
Ediscreation	Silent Switch OXCO JPSM	SWITCHING HUB	¥200,000		*		*	2
som	sNH10G Special Edition (10MHz/Silver)	SWITCHING HUB	¥269,500		*	*		2
phasemation	T1000	MC TRANS	¥330,000(pair)		*	*		2
Luxman	P750u Mark II	HEADPHONE AMP	¥350,000		*	*		2
bus	HPA1	HEADPHONE AMP	¥480,000			**		2
esoteric	Grandioso G1X	MASTER CLOCK GENERATOR	¥2,100,000			*	*	2
21 Fibrix	Staccato	HEADPHONE AMP	¥168,000			*		1
Fidelix	O Side Force	TONEARM	¥178,000			*		1
rega	System One	Planer1 mk2/10/Kyte Y220,000 (set)		*				1
My Sonic	Stage 1030	MC TRANS	¥300,000			*		1
Rin	Arko	TONEARM	¥500,000				*	1
soul note	B3	USB/ZERO LINK CONVERTER	¥480,000		*			1
Grants	MH1000S	TONEARM	¥790,000			*		1
accuphase	DF65	DIGITAL E. CROSSOVER	¥850,000		*			1
trinov audio	ST2 HiFi	SOUND OPTIMIZER	¥1,160,000		*			1

Other Component / Sound Accessory

21 Epsilon	MC-L SE	MC TRANS	¥2,300,000			*			1
	Graham Engineering Phantom Elite Ti 10inch TONEARM		¥2,600,000				★		1
	Bespoke Audio Passive Preampifier TRANSFORMER ATTENUATOR		¥2,700,000	★					1

sound accessories

First place Claudio CLN-LP200T ¥1,130,000



★
 ★
 ★★
 ★★
 Score 10-inch and 7-inch discs can also be supported with an adapter sold separately.
 5 Use purified water that can be purchased online I recommend. (Miura)

•The long-awaited return of the highly rated ultrasonic record cleaner. Although the price has increased, important parts such as the rotation mechanism have been improved, making it even more complete. I compared this model with the original one that I use regularly at Shiroya, and I felt that the new model was superior overall.

First place AGS Hybrid ANKHII (corner type) ¥340,000~¥470,000



★
 ★★
 ★★
 ★★
 Score
 installation in the corner of a room. (fuu)

•The center of the wall behind the speakers is the most effective place to install structural features such as reflection-diffuse sound absorption. The next most effective area is the corner of the room. Sound tends to accumulate in corners, so sound-absorbing structures are also desirable. This hybrid device, which has a forest-like AGS structure and a sound-absorbing structure, is suitable for

brand	MODEL NAME	Genre	price	ONO + size	Fu Mayuzumi	Miura	Yamamoto	SCORE
1 Hanlu	Mera Professional RB	RECORD CLEANER	¥740,000	★★★		★★		5
4 Krypton	PB-HR3000	AC POWER BOX	¥214,000			*	★★	3
AGS	ANKHI (Flat type)	ROOM TUNING DEVICE	¥280,000~¥380,000		★★★			3
AGS	Hybrid ANKH I (Flat type)	ROOM TUNING DEVICE	¥300,000~¥420,000★		★★★			3
AGS	ANKH II (corner-type)	ROOM TUNING DEVICE	¥320,000~¥430,000		★★★			3
accuphase	PS530	AC REGULATOR	¥430,000		*	★★		3
DS audio	ES001	RECORD STABILIZER	¥550,000		*	★	*	3
10 Kojo Technology	Crystal Ep	VIRTUAL GROUND PLUG	¥24,000	★★				2
light castle technology	Crystal E	VIRTUAL GROUND	¥34,400	★★				2
DS audio	ION001	VINYL IONIZER	¥170,000		★	*		2
AGS	ANKHVI (Floor type)	ROOM TUNING DEVICE	¥200,000~¥320,000		*	★		2
Quadraspire	Q4D Vent	AUDIO RACK	¥285,000 (set)★		*			2
Luxman	ES1200	CLEAN POWER SUPPLY	¥600,000			★★		2
accuphase	PS1250	AC REGULATOR	¥800,000			★	*	2
17 Audio Technica	AT607a	STYLUS CLEANER	OPEN (around ¥800)★					1
rega	Atlas Tracking Force	STYLUS FORCE SCALE	¥33,000			*		1
andante largo	SM5X/B4	INSULATOR	¥38,000 (1 set of 4, tax included)★					1
krypton	PB350	AC POWER BOX	¥59,000				*	1
acoustic	Systems SMARTtractor	ALIGNMENT PROTRACTOR	¥85,000			*		1
well float	BW001 Type4449L	AUDIO BOARD	¥107,800			*		1
QRD i	Diffusor	ROOM TUNING PANEL	¥100,000~		★			1
acoustic	Revive RPC1K	AC POWER CONDITIONER	¥341,000		★			1
well float	Babel	INSULATOR	¥600,000				★	1
artesanía audio	Exoteryc	AUDIO RACK	¥1,165,000 (3-stage specification)			*		1

Harbeth

New expressive power achieved through constant study.

This is the birth of the XD series, a new world of expressiveness pioneered by Harbeth. The name "XD" symbolizes "eXtended Definition", that is, resolution that exceeds limits. A fresh sound field and a sense of transparency were achieved by carefully reviewing the behavior of the speakers from the ground up and refining each component that makes up the crossover through repeated testing. Here is the proof of our tireless and repeated efforts.

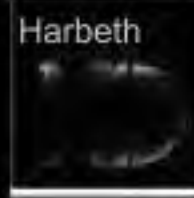

Super HL5 plus XD

3-way 3-speaker System Width
322 x Height 635 x Depth 300mm
¥900,000 (¥990,000 including tax) pair
•Special stand HSS-5 (H390mm) ¥72,000
(¥79,200 including tax) 2 units 1 set

HL-P3ESR XD 2-

way 2-speaker System width
190 x height 306 x depth 184mm
¥480,000 (¥528,000 including tax) pair

HL-Compact7ES-3 XD

2-way 2-speaker System Width
271 x Height 520 x Depth 310mm
¥680,000 (¥748,000 including tax) pair
•Exclusive stand HSS-7C (H430mm) ¥72,000
(¥79,200 including tax) 2 units 1 set

THE *Speaker*



RM10Z

Fundamental

Reference Monitor Speaker ¥540,000 (1 pair, tax excluded)

Floor stand ST10 ¥150,000 (1 pair, tax excluded)

Listening

You can listen to it in the listening room at the head office.



Made of special magnetic material developed by Mysonic

“Ultra-low impedance”
and “high energy output” create

- Ultra-low impedance, which improves internal loss and phase delay
- **Hi-BS** It has high energy output and
To obtain a wide dynamic range
- **Hi- μ** is for improving magnetostriction and transient characteristics.

The ultimate MC cartridge that achieves precise musical expression and speedy responsiveness.

MC type stereo cartridge

Signature Platinum

Standard retail price 825,000 yen



A gem of an MC cartridge that achieves calm and youthful expressiveness.

MC type stereo cartridge

Signature Gold

Standard retail price 715,000 yen

Make full use of the cartridge's sound quality



Lead wire for head shell
MR-1Rh (1 set of 4 pieces)
Standard retail price 4,400 yen

Mounting screws and nuts to ensure thorough emphasis on sound quality



Cartridge screws and nuts
SS-9 <29 pieces> Standard
retail price 3,300 yen

Adopts twin key lock system and bright rhodium plated contacts



(Silver)

(Blue Black)

Head shell SH-1Rh

Standard retail price 16,500 yen

*All prices include tax

2nd edition of the "effective" plug noise absorber that resonated with the world



It's been a year and a half since its release. evidence-based

Its reputation as a plug noise absorber is increasing day by day.

The long-awaited new item following PNA-RCA01 has arrived.

PNA-USB01 is a USB type noise absorber that is effective in the latest AV systems.

Just by plugging it into your PC, video equipment, digital audio equipment, etc., you can get close to the original sound and video quality.

YUKIMU SAA plug noise absorber is now very popular overseas.

That empathy continues to spread quietly.

YUKIMU SUPER AUDIO ACCESSORY PNA-USB01 Noise Absorber ¥45,000 (¥49,500 tax included)

Scheduled to be released in September 2022

YUKIMU SUPER AUDIO ACCESSORY PNA-RCA01 Noise Absorber ¥45,000 (¥49,500 tax included)

Now on sale



YUKIMU SAA PNA-USB01

yukimu

Yukim Co., Ltd.
1-41-9 Oi, Shinagawa-ku, Tokyo 140-0014 phone.03-5743-6202(main)fax.03-5743-0057
<http://www.yukimu.com>



csport

The ultimate multi-amplifier system for stereo playback

Analog crossover network with "transfer function G=1" without phase rotation.

[Slope characteristic -12dB/Oct]

2Way, 3Way, 4Way, and 3D configurations are possible.



-6dB/Oct matches the phase, but I would like to divide it with a steeper filter. However, if it exceeds -12dB/Oct, the phases will not match. Even if I reverse the polarity of the speakers or perform time alignment, the phases do not match. The newly developed "MK Filter" solves this problem.

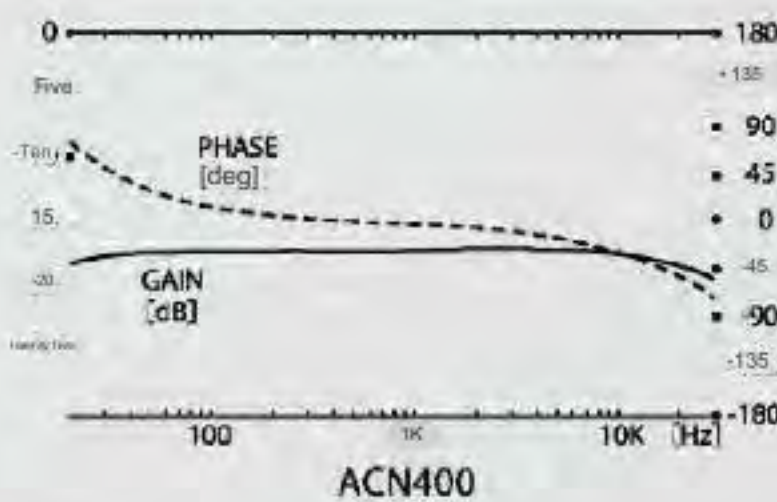
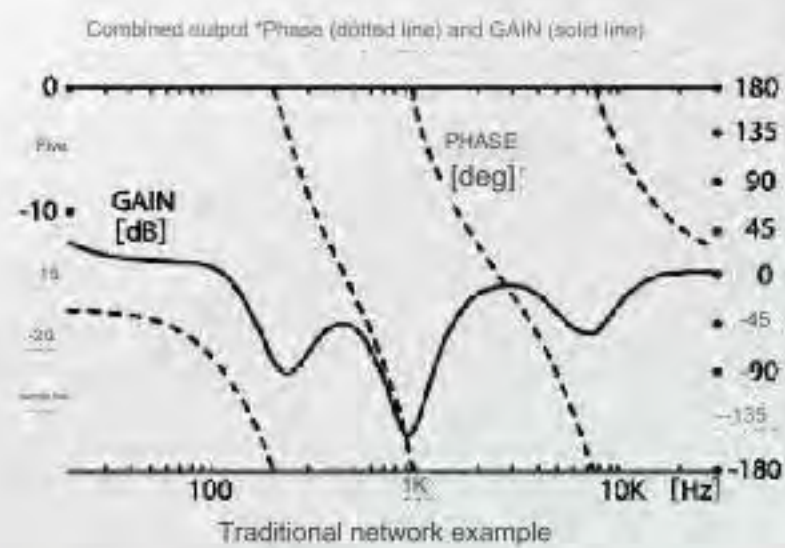

Square wave input and output *4kHz square wave input (top) and output (bottom)

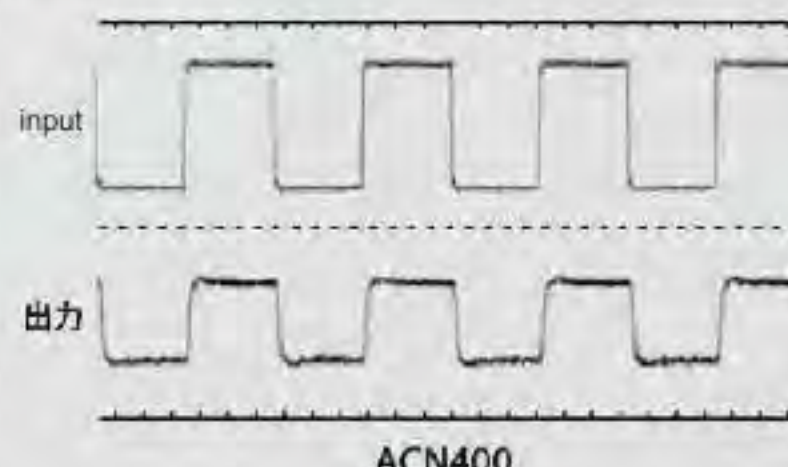
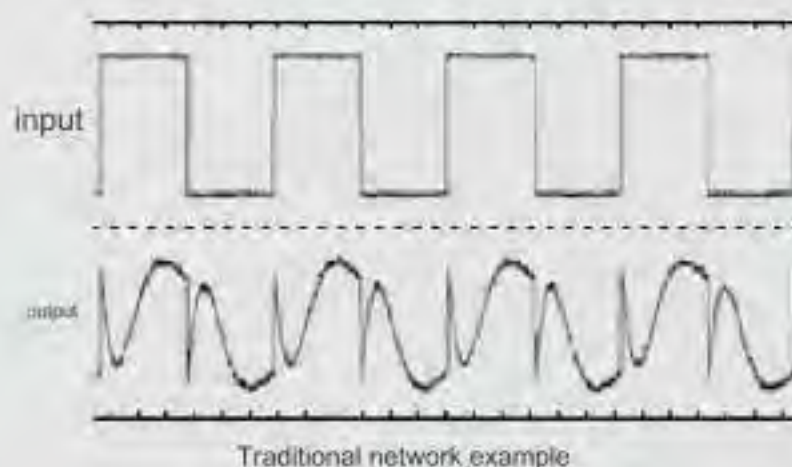

*The slope of each filter is fixed at -12dB. It cannot be changed to other slopes.

Active Crossover ACN400

◦Settable crossover frequency (by push button)

Low range/low mid range...63, 100, 200, 400 Hz...
FLAT Low mid range/high mid range...400, 630, 1000, 2000 Hz...
High mid range/high range...2000, 4000, 8000Hz FLAT

◦GAIN control for each channel
Resistance ladder type...0~-30dB



MC
Diamond

Something that marks a new supremacy. Air core, carbon, Diamond

The Ortofon Exclusives series

EMC Diamond List

price ¥1,180,000 (¥1,298,000 including tax)

Ortofon's treasure, the solid single-crystal diamond cantilever, the in-house produced damper that takes full advantage of its characteristics, and the high-precision WRAD system. This is the birth of MC Diamond, a flagship model created using the best materials and technology. Ortofon's philosophy of "authentic sound" has risen to the next level.

Transformer boost and balance

connection. This is the ideal of record playback and Ortofon.

Phono-Equalizer Amplifier MAX

EQA-2000 List price

¥540,000 (¥594,000 including tax)



"R" is for Reference.

The definitive static
balance tone arm

Tone Arm

NEW AS-212R/AS-309R

COMING SOON



MC Diamond



Challenging the limits of technology

and reaching new heights...

Introducing a high-end power cable
that suppresses vibration from inside
the cable using NI insulation rods!!

EVIDENCE NI AC S

¥462,000/1.2m ¥506,000/2.0m



Reduces noise that accumulates inside from empty terminals!!

■Noise ejector



EVO-NE0510NI-R
EVO-NE0510NI-Y ¥13,200

EVO-NE0510NI-XM
EVO-NE0510NI-XF ¥14,300

AET information www.ittech.jp now sells online shop limited products and outlet products!!

最大 **70%** OFF!

The excitement of music begins here.

Zonotone

A performance of the utmost perfection that leaves you deeply moved. The pinnacle of interconnect cables that goes beyond the "supreme".

7NAC-Shupreme

X 8-core 5-type hybrid top-end interconnect cable



The top-end Shupreme series has the ultimate in "pure & energy & There is an "extraordinary emotion" that comes from the "realistic presence." The Shupreme series is proud of not only its excellent scientific numbers. It goes beyond these numbers to fully reproduce the emotion hidden in the art of music. That's why the Shupreme series has been in the spotlight ever since its introduction.



The potential to reproduce the vitality and expressive power of music to the utmost.

An exceptional power cable that goes beyond the "supreme".

7NPS-Shupreme 1

5-core, 4-type hybrid, top-end power cable

The sound that comes out reflects a person's sensibilities and education.

It can also be a barometer of a person's "human strength".

The founder, Toshihiko Maezono, loved music and poured his heart and soul into audio. His personality and background are through the "Toshihiko Maezono Story" on N's official website. cable that can't be found anywhere. Learn more about the person Toshihiko Maezono's goal was to be able to connect cables and O. A Affinity with Diophile. The pinnacle of this is the "supreme" cable. This is the Shupreme series, which means height.

Pure and delicate sense of color and rich descriptive power. The ultimate top-of-the-line medal that goes even higher than its "overall height".

7NSP-Shupreme

X 7N 5 types hybrid bi-wire compatible top-end speaker cable

Quotation by Toshihiko Maezono, the founder of Zonotone [8]



Manufacturer: Maezono Sound Lab Co., Ltd.
4F Yamato Building, 5-20-4 Toyotakita, Nerima-ku, Tokyo 176-0012
TEL:03-6914-6255 FAX:03-6914-7566
<https://zonotone.co.jp/>



IKEDA IT-407SS

The music information extracted by the cartridge from the sound groove is delivered to the phono equalizer without any coloring. We have completed a tone arm that focuses on reproducing the "original sound." The hybrid construction, in which the main parts are made of stainless steel and the details are made of aluminum and brass, brings out the true sound of your favorite cartridge. Please come and experience IKEDA's current "achievement point" created by MADE IN JAPAN.

The point of reaching the "original sound". The new IKEDA is here to provide you with an answer to modern analog playback.

Total length: 388mm/Effective length: 307mm/Tracking error: +20°/35/Mass: 1.025Kg (arm alone) 1.679Kg (including OT-VTA-06)/Handle range: 0-5g/Arm height Adjustment range: 20-60mm/Accessories: IS-9SS IT-VTA-06 ¥1,375,000 (tax included)

Integrated shell MC cartridge

SAI Aya

¥418,000 (tax included)



Successor to the famous IKEDA 9MUSA/U Shell-type cartridge that combines the same vivid sound and stable playback as previous IKEDA cartridges

MC Cartridge Akiko

¥854,700

(tax included)



The new IKEDA 10th Anniversary Premium Model features a diamond cantilever and a PCOCC conductor coil wire, and the body is treated with pink gold.

MC cartridge

9 mono

¥262,900 (tax included)



A specially designed model for enjoying monaural records with modern stereo equipment, with monaural power generation coils arranged for each left and right channel.

tone arm elevation

IT-VTA-06

¥137,500 (tax included)

In addition to the IT-345/IT-407 arm base with a built-in elevation mechanism that allows height adjustment with a single dial operation even while playing records, it can also be used with the FR-64/66 with a shaft diameter of 25 mm. Masu



Step up transformer for MC cartridge

IST-201

¥283,700 (tax included)

Machined from an aluminum block. It is possible to bring out the performance of various cartridges, including the precision-machined low-loss MC cartridge transformer IKEDA9 series.



The future of listening
begins with electrocompanie

ELECTROCOMPANIE



ELECTROCOMPANIE

If music *really* matters™

 Made in Norway



ECI 6 MKII / Integrated Amplifier
¥1,200,000 (tax excluded)/¥1,320,000 (tax included)



ECM 1 MK II/Network player/DAC ¥980,000 (tax
excluded)/¥1,078,000 (tax included)



EMC 1 MKV/CD player ¥1,300,000
(tax excluded)/¥1,430,000 (tax included)



ECP 2 MK II/Phono Equalizer ¥480,000-
(tax excluded)/¥528,000 (tax included)



ECI 80D/Integrated Amplifier/DAC ¥680,000
(tax excluded)/¥748,000 (tax included)

•CS Field Co., Ltd.



775-1 Akada, Toyama City, Toyama Prefecture 939-8064

TEL: 076(491)2207 FAX: 076(491)3490 www.cs-field.co.jp customer@cs-field.co.jp



Super TMD

Contact
agent
Stabilizer

“Super Trans-Music-Device”

Recovering the “artisticness” lost at points of contact

- STMD - 1.5 ¥ 6,800 (1.5 ml)
- STMD - 3 ¥11,000 (3ml)
- STMD -10 ¥ 27,500 (10ml)



Andante Largo

Ingredients penetrate into the minute irregularities on the terminal surface. By expanding the points of contact and creating a stronger foundation, we increase the number of “reliable points of contact” and ensure the reliable transmission of music and video information. The new product “Super TMD” has a completely new formulation, including the introduction of new materials. It has made significant advances in all aspects, including durability, conductivity, workability, and musicality. Installation is easy in 2 steps. We also offer Super TMD comparison sets (one pair of analog cables coated with SuperTMD and one pair without). Please refer to our homepage for other details.



Noise Pump

Noise countermeasures are essential for high-end audio

ノイズポンプ

CHORD
COMPANY

Import source

Andante Largo
Official Homepage



•Click here for 1 week trial rental ↑

PowerARRAY

②Power array (noise pump for power supply)

- PA-3 ¥140,000 (3 pin type/1 piece)
- PA-2 ¥140,000 (2 pin type/1 piece)

GroundARRAY

① Ground array (device noise pump)

RCA/XLR male/XLR female/BNC

USB • HDMI • LAN (RJ45)

7 types in total

¥102,000/1 piece

PowerARRAY Professional

③Power Array Professional (power supply noise pump/flagship model)

- Normal model “Signature” ¥920,000/1 piece (80cm/3 pins)
- High-end model “Code Music” ¥1,150,000/1 piece (80cm/3 pins)

• Extension is also available by special order/The price difference between the above two models is due to the change in the cable part.

The main body design is the same (same level as the Code Music series).

Trusted and proven for over 10 years, with a track record of purchasing over 1 million items.

I have faith

Cash on the spot on the same day



(0120-197-3113 Audio-purchaser



Business hours: 10:00~22:00

Nationwide business trip possible

Open all year round

Strict confidentiality

<https://audio-kaitori.jp/>



audio buying shop

search

*If you wish to make an acquisition, please present your identification documents, such as a driver's license or passport to a member of staff in accordance with the law.

*Depending on the condition, there may be items that cannot be added to the price you requested, or items that may not have a price attached to them.

*Depending on the season or nature of the situation, it may be difficult to conduct an on-site assessment or respond on the same day.

*Purchase from minors is not possible.

Free on-site appraisals nationwide in as little as 30 minutes on the same day.

We have been in the audio purchasing business for over 10 years, with over 100,000 purchases and a purchase price of over 1 billion yen.

We purchase not only audio equipment, but also a wide range of peripheral accessories and racks, and we believe in responding to our customers' needs in detail.

We have our own repair workshop, so even if there is a problem with the audio, we can buy it back. We offer free on-site assessments, so please feel free to use us at least once to find out how much your audio will cost.

Please contact us even if the item is broken, irregular, or dirty. We are fully equipped with our own workshop, which will help you avoid discounted appraisals.

▼ [Absolutely expensive purchasing manufacturer]

Accuphase

McIntosh

Mark Lev 1501

LUXMAN

Tannoy

Sonus Faber

Thorens

Esoteric

Western
Electric

■ Purchase items

Speakers, power amplifiers, preamps, integrated amplifiers, vacuum tube amplifiers, AV amplifiers, CD players, cassette decks, net soak players, record players, tone arms, cartridges, open reel decks, LD players, headphones, Harm Theater, Reno Yares Speakers, power supply densityers, equalizers, D/A-converters, D/D converters, accessories, and other audio equipment

Items other than those listed
are welcome!!

Make Your Analog Life Style

Bringing analog bliss to you

AR
EX
1000

Over 2000 years old YAKUSUGI
Solid Wood Body
Special Nude Ruby Cantilever
Super Curve Line Contact 2 Stylus



Analog Relax EX1000 Phono Cartridge

AR-MCC-EX10001,280,000 yen (1,408,000 yen including tax)

A

EX
500

Violin Neck & Back Plate Tone wood
Hard Maple Solid Wood Body
Super Polishing Elliptical Stylus
High Purity Silver Coil



Analog Relax EX500 Phono Cartridge

AR-MCC-EX500480,000 yen (528,000 yen including tax)

AR
EX
300

Guitar Side & Back Plate Tone wood
Walnut Solid Wood Body
IF Adhesive Elliptical Stylus
High Purity Copper Coil



Analog Relax EX300 Phono Cartridge

AR-MCC-EX300 250,000 yen (275,000 yen including tax)

AR
ANALOG RELAX

Zoot Communication LLC 1-1-2-717 Funabori, Edogawa-ku, Tokyo 134-0091
03-3675-6649 zootcommunication@gmail.com <https://analogrelax.com>



<http://www.elex.ne.jp/>



Goto unit all horn listening device

Behringer CX3400
V2 tuned with plug
¥ 24000

Classic Pro Digital
Power Amplifier Tuner
¥39000

Each pair ¥7000

Purchase/Trade-in/ consignment sale

There are many other than USED stock list:

<p>*Speaker system</p> <p>Altec A5 ferrite...pair 448000 Altec A7 Alnico...pair 403000 Altec 755E+EDISON box...pair 120000 Altec 400B DIGmk2BOX1/160000 Altec MiniMonitor8A Pair 65000 JBL HL91</p> <p>Altec 305 Pair 60000 ALTEC 301H Bear 62800 EV Aristocrat, double axis, pair 200000 Goodman Axiom 201 + domestic box pair 11500 Goodman Axiom 301 Domestic Box Pa/124000 Jensen A-12 + neets + box + power supply, pair 220000 Jensen A-12 + corner box + power supply pair 20000 JBL 4343BWX Bear 495000 1B1 Lancer 101 style...Pair 106000 GE \$101207+TW+rear open box...Pair 85000 Siemens (72233 040 A1 box/55000 True Sonic 206AXA+4560 pairs Pair 290000 Harves HL Compact... Bear 40000 Bozerk BARD Pe/85000 Rouser PM6+ Backroad Pair 268000- Rinsui Mini Monitor 2115...Pair 106000 Coral BL 25/Beta 10...Bear 138000 Diatone P-610+80X35900-Fostex H425...Foster Maxonic ATORES 1925954034850/23100 pair 180000 Nagaoka style 0118.1+TabgBand pair 32000</p> <p>*Speaker unit</p> <p>Altec 511B black. pair 38000 Artek 8118. Pair 35000 Altech N-500-D. pair 80000 Altech 515-BG- Pair 99000 Altech N1201-8A- Pair 28000 Altec N1501-B. Pair 35800 quad+... EV 30W 1 bottle 30800-103300 Jensen DL 220/Scarred... Bear 75000</p>	<p>JBL 2445J pair 65400 JBL LE55 Pair 69000 JBL 2345. Pair 32000 JBL 239712328- Pair 65400 181 1717+1219 Gray (1187) Pair 87300 JBL 2327 Pair 17000 Altec 0208/ Pe/53800 JBL 22058 Bear 89800 JBL LE14H/Edge Kai...Pair 39800 JBL LE15H... Pair 50000 JBL LE15A/Edge Kai...Pair 142000 JBL 22203... Pair 48000 140-B... Pair 38000-40000 D130 fix... Pair 89100 + Player Bear 35800 JBL LX2 Be/53200 JBL 31206- Pair 44800 JBL 3110. Pair 32000-35800 JBL N2400... Pair 14800 JBL 4560... Pair 50000 Tannoy Monitor G15...Pair 360000 Philips AD5061/M8+ .. Bear 20000 Coral A11-500... Pair 40000 Counter PSA-270/Fine 100000 SAE 2600 99800 SAE XXX. 69800 Counter PSA-270/Fine 100000 Cambridge Audio AXA3535000</p>	<p>Macintosh MC607358000-448000 Mark Levinson LNP2OLD 1350000 Mark Levinson ML-2...pair 891000 Marantz #7/with case 495000 SunAUDIO SV-IL/2A3PX type-15380000 Sony TA-N86 30000 Takahashi Audio EL34PP...Pair 270000 Flying Mail ML...Pair 25000 Mail M-100por...pair 15000 Macion M-511...pair 220000 lux(L352- 119700 Rotal RB-870- 20000 HMA-9500- 187400 Special order 845 single 162000 Parade 301 white + cab + amp 448000- Garrard 401 Cab Arm 198000- Lin 1P12+SMF300953 297000 Technics SP-20 32000 SP-10-45000 Denon DP75. 23000 Ortofon SPU Series...50000- Sure V15TypeII-V- 20000 Decca MK2 Stereo 71800 SME 30091MP 71800 Ortofon 212 series...71800- Decca Mark1 Super... 31500 FR 645- 180000 Studer MC transformer 89800 Philips LTH2000- 1090000 Lubox 8226-5 100000-124000 Esoteric PO... 628000 Nakamichi MB-1 changer 64800 Hegel HD10... 60000 BULOVIAT-2148 line transformer...25000</p>
--	--	--

USED audio products

Many items are on display

You can listen to USED items. Even just for repairs and consultation and for sale, please feel free to contact us.

Business hours: 10:30-20:30 (unspecified end) Closed: Wednesdays (except 1st Wednesday of the month) and 1st and 2nd Thursday of the month

☎ 326-0837

3495-2 Nishiaricho, Ashikaga City, Tochigi Prefecture

TEL : 0284-64-7346 FAX : 0284-64-7347

Mail order Cash on delivery card accepted Bank account: Ashikaga Bank Hajika Branch Regular 3043447 Elex Iwata Ryutarō



Suisendai annual first sale will be held on January 2nd, 3rd and 4th, 2023!

QR code below
読み取って下さい!

Relax and calm your mind with your favorite music.

Thanks to you, we are celebrating our 42nd anniversary.

Sendai Central Post Office Ura Kitame-cho, conveniently located by car or on foot

022-266-7761



FAX 022-213-7656

URL <https://www.sendai-nodaya.jp>

E-mail sendai-nodaya@cotton.ocn.ne.jp

business hours AM 10:00~PM 7:00

Closed on Tuesdays, one consecutive holiday a month. Please leave the delivery settings within the prefecture or nearby prefectures to us!

42nd anniversary of opening

Winter sale is underway!

納得 price!

<p>Fusion of advanced technology and sophisticated functions</p> <p>LUXMAN L-507Z (Japan) ¥693,000 (tax included)</p>	<p>Luxury design that stimulates ownership</p> <p>LUXMAN PD-191A (Japan) ¥990,000 (tax included)</p>	<p>New flagship power amplifier with an updated amplification circuit</p> <p>LUXMAN M-10X (Japan) ¥1,650,000 (tax included)</p>	<p>The ultimate in sound with the latest technology</p> <p>Constellation Audio Stereo 1.0 (USA) ¥2,750,000 (tax)</p>	<p>Preamplifier with both multi-function and operability</p> <p>McIntosh C53 (USA) ¥1,100,000 (tax included)</p>	<p>A rack that purifies</p> <p>Andante Largo (Japan) TowerS865 (5 tiers) ¥810,000 (tax included)</p>	
<p>Pure A class 22W+22W output</p> <p>Triode JUNONE 845S (Japan) Premium ¥966,000 (tax included) Shop</p> <p>MQA compatible SACD player latest model</p> <p>LUXMAN D-07X (Japan) ¥825,000 (tax included)</p>	<p>FOCAL Maestro Utopia EVO (France) ¥8,800,000 (pair/tax included)</p>	<p>Click here for Sendai Nodaya special selection/recommended selling products!!</p> <p>Confident in the price!</p> <p>Noda expert Kono President of Sendai Nodaya Ryu Noda expert</p>		<p>A masterpiece that challenges the pinnacle of network DACs</p> <p>ESOTERIC N-01XD (Japan) ¥1,760,000 (tax included)</p> <p>Rich musicality that will be loved for many years</p>	<p>Extremely effective against power supply noise</p> <p>CHORD COMPANY PowerARAY Professional (UK) ¥920,000 (tax included)</p> <p>W. B. Schottky Power supply noise filter</p>	
<p>Unique design</p> <p>JBL L100 Classic (USA) ¥550,000 (pair/tax included)</p>	<p>An ambitious work that challenges the pinnacle of all-in-one SACD players</p> <p>ESOTERIC Grandioso K1X (Japan) ¥3,190,000 (tax included)</p>	<p>Another experience with a technology of sound dispersion</p> <p>TechDAS Air Force V Premium (Japan) ¥1,540,000 (tax included)</p>	<p>Luxman for the first time in 40 years</p> <p>LUXMAN (Japan) LMC-5 ¥264,000 (tax included)</p>	<p>Another level of clarity</p> <p>Harbeth (UK) HL-Compact7ES-3 XD ¥748,000 (pair/tax included)</p>	<p>TANNOY Tumbery/GR (UK) ¥1,298,000 (pair/tax included)</p>	<p>B&W 802D4/MR (UK) ¥4,114,000 (pair/tax included)</p>

全品 rush of orders! Kindness and politeness! Product knowledge from specialty stores!

- Home page
 - Twitter (Sendai Nodaya)
 - Facebook (Sendai no Daya)
 - LINE (Sendai Nodaya)
- Check out the latest information!

Bank Account Name: Sendai Nodaya Co., Ltd.
Transfer Bank: Bank of Sendai Branch (Sendai) Deposit No. 0356573

5-3 Kitame-cho, Aoba-ku, Sendai 980-0023 (Behind Sendai Central Post Office)



価格

By making full-use of our expertise and services, we will be able to offer you a price that you will be satisfied with. It is our endeavor to do our best to accommodate your budget.

responsibility

Sendai no Daya is responsible for setting up the purchased audio equipment in your home, etc. We will take responsibility anywhere within Miyagi Prefecture, and will respond as much as possible even outside the prefecture. Please note that you may be required to pay actual costs for deliveries outside the prefecture, so please contact us for details.

安心

Please leave the aftercare to us after purchase. For aftercare outside the prefecture, please contact each You can also go directly to the manufacturer.

Now in Sendai it's true! We are confident in our low prices, so please give us a call or visit us to check it out! We will introduce you to products that match your budget and tastes. We will never force you to come to our store. Please make sure you are satisfied before purchasing. Our experts have over 10 years of experience. Yago CZAAN

- Closed every Tuesday (open if Tuesday is a holiday)
(Monday/Tuesday or Tuesday/Wednesday off once a month)
- Trade-in OK
- Credit lump sum payment with no interest rate
(No interest paid in lump sum until the end of August 2020)
- 3~120 times credit (with interest)
- We welcome inquiries and business negotiations over the phone.
- Setting outside the prefecture is also OK
(Actual expenses such as transportation expenses may be charged)

Will the world of audio hobbies disappear from this world?

Stop the disappearance of audio culture!

A spectacular high-end audio corner

Forty years ago, during Japan's period of high economic growth, there were several audio specialty stores in every town. Every store had the coveted new amplifiers and record players from Japan and abroad, and the listening room had a large display of heavy-duty speakers. At that time, the store was filled with audiophiles, and I was one of them. However, the audio specialty stores in the city have disappeared one by one, and the high-end audio section is now squeezed into a corner of a large electronics store in the city center. At that time, it was a matter of pride to have a hobby in audio, and I would invite my friends over to my house to listen to the audio I had just bought.



I remember being proud of it. After a while, Sony released the Walkman, and music that could be taken outdoors became a boom, and the author accepted it. Later, LPs were replaced by CDs, which freed them from the maintenance and noise inherent in records, and made it possible to easily enjoy music with integrated components. Nowadays, many young people listen to music on their smartphones for a fixed fee and don't know the joy of collecting LPs and CDs.

The balance between demand and supply is disrupted

However, audio equipment manufacturers As if ignoring the trends of the times, the company continued to create coveted audio equipment for audio fans like the author. While this was a good thing, it also upset the balance between supply and demand. Before they knew it, high-priced audio products were being produced in small batches. These prices became unconventional and could only be purchased by elderly people with high disposable income who were close to retiring from audio hobbies, or by people with a certain amount of money to spare. A customer at a high-end audio corner in a large electronics store If you look at it, it's obvious.

Retiring in 10 years

Many people including the author are thinking of retiring soon

For those who live in the world of high-end audio, the worry is, "Will someday the hobby of high-end audio disappear from this world?" The people who continued to support the audio boom of the past will be forced to retire in another 10 years, and I wonder what will happen to the many audio systems across Japan that have lost their owners. I end up. However, there is hope. This is due to the recent resurgence of vinyl records and the fact that manufacturers have begun producing new record players. In addition, a new audience is emerging who love PC audio, high-resolution audio, and the audio that the author was so passionate about, taking a new approach. It is.

I would like you to lend me your strength so that audio culture does not disappear.

Therefore, I have a suggestion for readers. Before I retire, I'll buy the latest audio once again and immerse myself even more deeply in the audio hobby, or I won't let audio culture die out as my father's hobby from the Showa era.

audio
Purchase

Free on-site store delivery



Pay in cash on the spot

Free business trip and assessment

If you are interested in audio,

I want audio equipment to be passed on to the next generation who started it. Listening to your favorite music through earphones is great, but we want the next generation to experience the excitement of "Isn't it even better when you listen to it through good speakers?" If you have audio equipment that you do not use, please contact Audio Sound, a specialist audio purchasing store. At Audio Sound, our president, who loves this wonderful world of audio hobbies, has decided to "bring the audio owner to the next owner in order to prevent the "audio culture from disappearing." We are working on a mission. In fact, the author, who is an audio enthusiast, was so impressed by this idea that he started working as a buyer. Also in the foreground, but with just one phone call, in about 30 minutes at the earliest, a professional who is knowledgeable about audio will come to your home and set up your audio. Correctly judge the value of DIO and buy it. He will take it. Now it's "Stereo" If you say "I saw the sound!", this magazine 13% purchase price increase for readers only Click. Our thoughts on this occasion I would be happy if you could convey that.

audio sound

Now available nationwide!

We will visit you anywhere in the country for a free assessment. Please show us first. Call now!

Setagaya store Otsuka store Iwatsuki store Tokorozawa store

Fuchu store Yokohama store Utsunomiya store Senzai store

Maebashi store Shizuoka store Hamamatsu store Nagoya store

Suita store Kyoto store Nishinomiya store Hiroshima store

Hiroshima store Kokura store Kumamoto store etc.

Audio purchase specialty store Call now

audio sound

Reception hours 9:15-20:30

13% UP! I saw stereo sound!"

- Many buyers are audio enthusiasts. There is a mind to work with your audio.
- Constantly conduct price surveys to understand the balance between demand and supply. We can present you with a reasonable appraisal price.
- We have a wealth of experience in purchasing everything from vintage audio to high-resolution audio, so you can rest assured.
- No matter how expensive the audio is or how large the quantity, we can buy it on the spot with cash.
- If you sell audio accessories etc. in bulk, the purchase price will increase!

Steps to free on-site assessment

1. Call the number below on your mobile or landline. Please contact us first. At that time, he said, "I saw stereo sound!"
2. If you like, please let us know the purchase price you expect by 10:00.
3. Tell the person in charge how to purchase. Please
4. Schedule function, location, application, etc. Please tell us your request.
5. We will call you to confirm the details of the purchase.

Fu will ask you.

- ☑ If you are satisfied with the purchase price.
- ☑ We will make an immediate payment on the spot.

0120-210-448

Store staff may be absent due to on-site purchases. Reservations are required, so please contact us in advance. *At the time of purchase, your identification card will be required.

<Management> Recycle Meister Co., Ltd. Antique dealer license number Tokyo Metropolitan Public Safety Commission No. 305590806398 and other prefectures have obtained



Accuphase 3900
 cuphase ¥2,200,000 (tax included)



The second stage of the Accuphase 50th anniversary model is now available. The newly installed "Dual AAVA" reproduces overwhelming silence and even the atmosphere of music.

SACD transport DP-1000
 ¥1,430,000
 (tax included)



Digital processor
 DC-1000
 ¥1,430,000 (tax included)

The third model commemorating Accuphase's 50th anniversary. Various technologies are being used to extract all the information from the disc.

ESOTERIC

Analog player
 GrandiosoT1 ¥7,700,000
 (tax included)



The long-awaited and finally completed magnetic drive system allows you to enjoy a new level of analog sound that can express both rigidity and quietness at the same time.

ESOTERIC

Power amplifier
 GrandiosoM1X
 ¥5,720,000 (pair) (tax included)



The sound of ESOTERIC's unique ES-Link Analog (current transmission) freely driving the speakers is worth a listen.

YES ACQUISITION

Hailey2.2
 speaker

This is a state-of-the-art speaker that uses the hard dome/soft dome hybrid tweeter "Billet Dome," which is installed in the higher-end model SonjaXV.



¥9,460,000 (pair) (tax included)

B&W
 Bowers & Wilkins

805D4
 speaker
 ¥1,122,000 (pair) (tax included)

The enclosure configuration has been redesigned to achieve even quieter performance. It creates a sound image that exceeds its size. (Price revised from January 2020)



IsOTEK



V5 AQUARIUS clean
 power supply
 ¥456,500 (tax included)



V5 TITAN clean
 power supply
 ¥770,000 (tax included)

A new series that has undergone a major evolution from EV03 to V5. Further noise countermeasures raise the musical expression of the system to a higher level.



B&W

Bowers & Wilkins

801D4

Speaker The

long-awaited "D4" has finally been announced. Once again, it was completed with quality and sound design that far exceeds its predecessor.

(Price revised from January 2020)

¥5,456,000 (pair) (tax included)

We support all of Western Japan!

Please feel free to contact us even if you are far away.



Fukuoka store EX ROOM



Kokura store EX ROOM



Mitsubishi Kokura main store



Theater room 7.1.2ch Dolby Atmos, 4K
 Compatible theater room. Impressive 150 inches
 The screen draws you into the movie.

Music Hall Twilight

- Music Hall Twilight is a music space that opened on the 2nd floor of Max Audio Kokura store.
- We regularly hold live jazz and classical music performances.
- It can also be used for dinner, parties, or as a bar by reservation.
- With the nostalgic sound of JBL Baragon in the background.
- Why not enjoy music in a space where you can enjoy a relaxing moment?

For more information, please contact Max Audio Kokura store.
 TEL.093-591-0469 MAIL kokura@maxaudio.co.jp

Check the latest information on MAX
 AUDIO official account!

Twitter
 @maxaudio_tw

Instagram
 @maxaudio_insta

Facebook
 @maxaudio.official

Max Audio Fukuoka store

Fukuoka Prefecture 1-9-12 Kusakae, Chuo-ku, Fukuoka City
 TEL.092-734-6789 FAX.092-734-6782

fukuoka@maxaudio.co.jp

Max Audio Max

AUDIO

www.maxaudio.co.jp

Max Audio Kokura store

2-10-15 Shimizu, Kokura Kita Ward, Kitakyushu City, Fukuoka Prefecture

TEL.093-591-0469 FAX.093-582-7500
 kokura@maxaudio.co.jp

The Sound Pit is divided into New Audio Corner, Vintage Audio Corner, Service Corner, Loft Corner, and Used Products Corner, allowing us to meet a wide range of customer needs.



NEW AUDIO

New audio corner



*We have many other vintage products in stock.



Vintage Audio

café & vintage corner

For purchasers
New Year's sale
Sound Pit
Original Calendar
Present

*Quantity is limited (first 50 people)

XRCD-SACD
esoteric
Various SACDs
Now in stock.



Stressless
EKORNES
We handle it.



audio equipment
tuning

listening room
sound check

audio room
design

listening room
consulting



Sound Pit NEWS

A new space has opened next door! We look forward to your visit with a more extensive selection of products.



A new website specializing in vintage audio is now open!

vintage-sound-pit.jp



Click here for a list of used items. The latest available items can be viewed using the QR code.

www.sound-pit.jp/used-audio-select

Please also check out our blog!



"Thinking about audio"
Manager's blog

soundpit27.exblog.jp



"Our audio"
Young staff blog

bokutachi.exblog.jp



SOUND PIT
High-end & Vintage Audio



Please see the website for the latest information.

<http://www.sound-pit.jp>

soundbit search



052-775-7901

2-13 Kamisha, Meito-ku, Nagoya 465-0025

Closed: Every Wednesday and Thursday (open on public holidays)

Weekdays AM10:00-PM8:00 Sundays and holidays AM10:00-PM6:00



NAVI 2-13 Kamisha, Meito-ku, Nagoya City



Music at the coffee shop next door
You can enjoy coffee.

Sound Space inc

- McIntosh
- Accuphase
- mark Levinson
- KRELL
- Threshold
- Boulder
- BARCO
- e/p
- THORENS
- ortofon
- SME
- SHURE

M **MAGICO MODEL 6**
4-way Speaker System
¥21,000,000 (pair)

- Wadia DIGITAL
- Acustik La 5
- PHILIPS
- TANNOY
- JBL
- ALTEC
- audio research
- EXCLUSIVE LUXMAN
- Pioneer
- ONKYO
- TEAC
- chario
- BARCO-EMT
- DENON
- KENWOOD
- EGOTERIC
- QUAD
- BOSE
- Burmester
- VIOLA

VIOLA Reference Preamplifier
SPIRITO ¥5,145,000



BRAVO Reference Amplifier
¥4,935,000

McIntosh
C-1000+C-1000T ¥2,520,000



McIntosh
Power Amplifiers 2KW
¥9,240,000

McIntosh
Power Amplifiers 1.2KW
¥1,470,000



METRONOME TECHNOLOGIE

DA Converter C2A Signature ¥3,150,000

METRONOME TECHNOLOGIE

CD Transport Kalsta ¥4,410,000

We will ship anywhere in the country.

SOUND SPACE Fukuoka



Komaba Building 1F, 3-4-10 Hakataki Higashi, Hakata-ku, Fukuoka City

TEL 092-481-5655 FAX 481-5255

SOUND SPACE Obihiro



Nishi 15-jo Minami 1-chome, Obihiro City, Hokkaido (facing Obihiro Onsen)

TEL 0155-35-5654 FAX 35-6643

A space that values the encounter between people and sound



- Delivering carefully selected sounds from around the world
AUDIO & VISUAL specialty store

Tereon

www.tereon.co.jp

<Sound Hall of Fame Sound One Ten>

Teleon 2nd store sound 110 We handle everything related

to "sound" including "purchase/trade-in and sale of used products" for single audio products.

We have a surprising selection of products! Please feel free to let us know!

The listening room on the 5th floor is also a must-see! For inquiries, please contact the 2nd store 2F/3rd store!

Displaying tax-included prices based on the new consumption tax rate of 10%

WEB mail order only @ www.tereon-tsuhan.com

Excellent sound quality - the joy of owning it! - New and popular products arriving quickly!!

LUXMAN



PD-151MkII ¥393,800 (tax included)

A record player system equipped with a newly developed knife-edge tone arm based on the previous model PD-151 completed in July 2021. The usability is the same as the previous version, but the sound quality is even better. It's selling!



D-07X ¥825,000 (tax included)

Container of the top model D-10X released in April 2020 Condensed Sept. Although it uses the same ROHM DAC chip as the D-10X, the sound quality is clear and open. It's selling!

ESOTERIC



K-03XD ¥1,320,000 (tax included)

Equipped with a new drive mechanism "VRDS-ATLAS" and "Discrete DAC" directly descended from the flagship Grandioso K1X, it achieves sound quality that even exceeds its predecessor. It's selling!

T.A.D.

TAD-E2-WN
¥1,738,000 (tax included, pair)
TAD's unique coaxial type mid/high range unit Without using knit "CST", we dare to 2.5 way with independent driver A floor type made up of. The finish is walnut only. The vast sound field and expressive power are attractive. It's selling!



Accuphase



A-300 ¥1,485,000 (tax included)

A pure class A monophonic power amplifier that boasts a continuous output of 125W/8Ω. Achieved sound quality befitting a flagship, including an improved S/N ratio! Selling!



C-2900 ¥1,540,000 (tax included) 50th anniversary after the flagship C-3900 preamplifier. Equipped with "balanced AAVA" for volume adjustment. Achieved an outstanding S/N ratio. It's selling!



E-4000 ¥693,000 (tax included)
A new integrated amplifier that replaces the E-480. Electrical Although the specs are almost the same, the sound quality is much improved. YAMAHA It's selling!



E-280 ¥396,000 (tax included)
The difference from the previous E-270 is the rear panel option. The number of application slots has been increased to "2 slots", allowing the AD-50 and DAC-50 to be used at the same time. It's selling!

DENON



DCD-A110 ¥336,600 (tax included)
PMA-A110 ¥393,800 (tax included)
SACD player and integrated amplifier of the four models commemorating Denon's 110th anniversary. Introducing the latest parts and circuits for each. The exterior is "graphite silver." It's selling!

marantz



MODEL40n ¥286,000 (tax included)
A high-end model that develops the concept of the best-selling NR1200 and improves sound quality. Enhanced internet support in fact, of course, high-power analog specifications. The output stage provides a spacious sound quality. It's selling!



NS-3000 ¥1,100,000 (tax included, pair)
The NS-5000's brother is finally here! The small baffle surface creates a vast sound field. I don't get tired of listening to it more than the NS-5000. It's selling!

Bowers & Wilkins



801D4(B) ¥5,456,000 (tax included, pair)
It has been about 5 years since the 800D3 series was released. Firstly new work introducing the "800D4" series. The structure of the top panel has been improved, and the squawker's "damper" has been improved for 8 years. It achieves overwhelming "sound separation" and "ultra" resolution. It's selling!



805D4(B) ¥1,122,000 (tax included, pair)
805D4 also has the same enclosure as the higher-end model. structure, and the sound quality is further improved. I did. Dedicated stand FS805D4 (¥169,400 tax included) will also be released at the same time. It's selling!

TRIODE



EVOLUTION ¥550,000 (tax included) You can hear the power of 40W with the same compact form! "Coming" tube amplifier. The body is like a piano with a luxurious black finish. 40W with KT88 push-pull +40W (80) maximum output. It's selling!

♪Notice of audition♪

from mid-December onwards will be announced on our website.

■Notice of change in business hours

Open all year round for the time being/11:00~19:00

sound 110



5F listening room 11:00am-8:30pm every day

We have a wide range of cables, accessories, cables, headphones, home theaters, and more! We also have a trade-in program!

<Example of 5F listening room>

- Accuphase DP-950+DC-850,C-3850 etc.
- ESOTERIC:Grandioso C1,S1 etc.
- B&W:802 D3(3)
- JBL:4367WX,DD87000
- LUXMAN:C-900L+M-900L

The latest information for each store is available on our website.

3rd store Areon



From vintage to recent make a diverse range of things. Manufacturers and outlets including used items. We also handle Trade-in/purchase too. Please consult us.

Teleon Co., Ltd.

第2店 Sound110

When it comes to audio, a scale of 1 to 10 is OK. You can also experience the ultra-luxury plane of your dreams!!!
1-3-11 Sotokanda, Chiyoda-ku, 101-0021
TEL:03(3251)5535(Main) FAX:03(3253)4506

Day one store

"Used Audio & Outlet" Upgrade on a small budget! 2-23
Kanda Suda-cho, Chiyoda-ku, 101-0041
TEL:03(3253)0070 FAX:03(3253)4508

第2店 2F

Used/exhibited items, outlet items! Feel free to trade in/purchase!
1-3-11 Sotokanda, Chiyoda-ku, 101-0021
TEL: 03(3253)1904 FAX: 03(3251)7426

For inquiries regarding high-end components,
TEL.03-3253-1904
FAX.03-3251-7426

TEL.03-3253-4509
FAX.03-3255-3816

Directly to mail order department

TEL.03-3255-3819
FAX.03-3255-5085

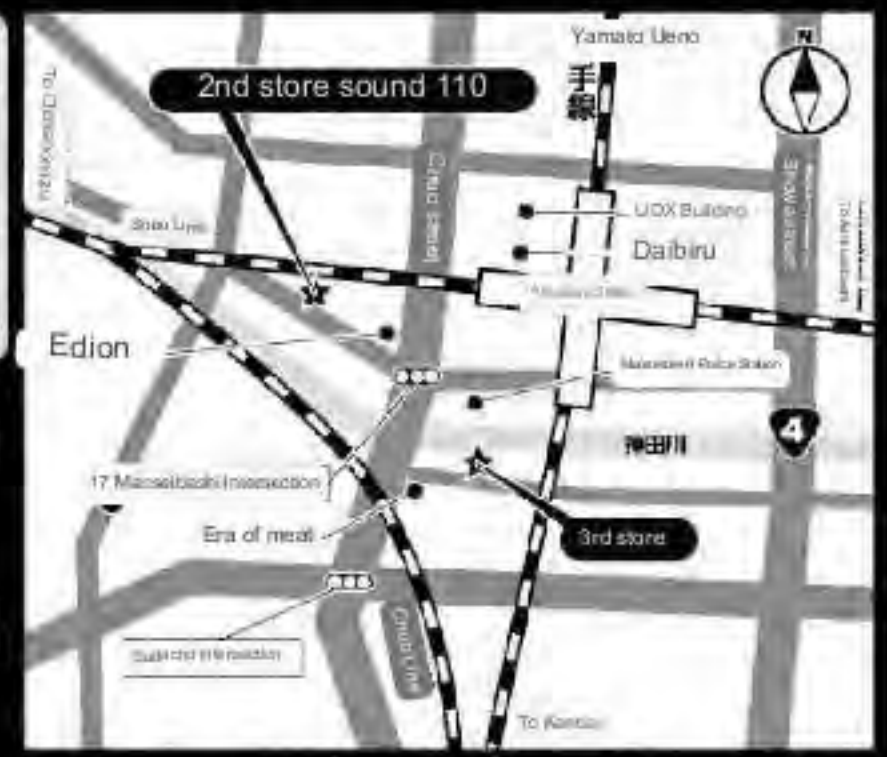

*You can also trade in with the purchase of the 5th floor store by credit card etc. Thank you for your interest.

since 1928 CAVIN Osakaya

Cabin Osakaya, a store where you can encounter authentic sounds

EGOTERIC



Analog turntable Grandioso
T1 Fukutoku
7,700,000 yen (tax included)

T.A.D.



Speaker system
TAD-CE1TX
Price: 2,970,000 yen (pair) (tax included)

B&W
Bowers & Wilkins



Speaker system
801 D4
price 5,214,000 yen (pair) (tax included)

EGOTERIC



monaural power amplifier
Grandioso M1X
price 5,500,000 yen (pair) (tax included)

YG ACOUSTICS



Speaker system
Hailey2.2
price 9,460,000 yen (pair) (tax included)

These are the main products that are currently

available for preview. *Prices of listed products are as of December.

1F Classic/Jazz CD floor

We also have a wide selection of high-quality CDs, domestic and international SACDs, and analog LPs.

Please stop by once. Email soundpark@osakaya.com

CD/high price trade-in
Purchasing in progress



Cabin Osakaya is in front of the clock tower!
2 minutes walk from Odori subway station!



- ① Furukano parking lot (Kita 1 West 3)
- ② Sapporo Odori underground parking lot (Odori West 2)
- ③ Kita 1-jo underground parking lot (Kita 1 West 2)
- ④ Maru-en Parking (13 West 3)
- ⑤ STV Tower Parking (North 2 West 2)
- ⑥ Times 24 (North 1 West 3)

For customers who purchase over 1,000 yen including tax, we will provide a parking ticket for up to 1 hour.
*Customers using Times 24 will receive a 40-minute ticket.

Trade-in/purchase high price appraisal

CAVIN
Osakaya

In front of the clock tower, Kita 1-jo Nishi 3-chome, Chuo-ku, Sapporo

☎011-221-0181 FAX011-221-0215

Business hours: AM10:30~PM6:30 (closed every Wednesday)

You can also consult about sound and shop on the internet.

<http://www.osakaya.com/>

Please also use email. audio@osakaya.com



S type

MH-1200S

¥790,000 (¥869,000 including tax)

Price revision 2023.1~

¥900,000 (¥990,000 including tax)



LUXMAN PD-191A installation image

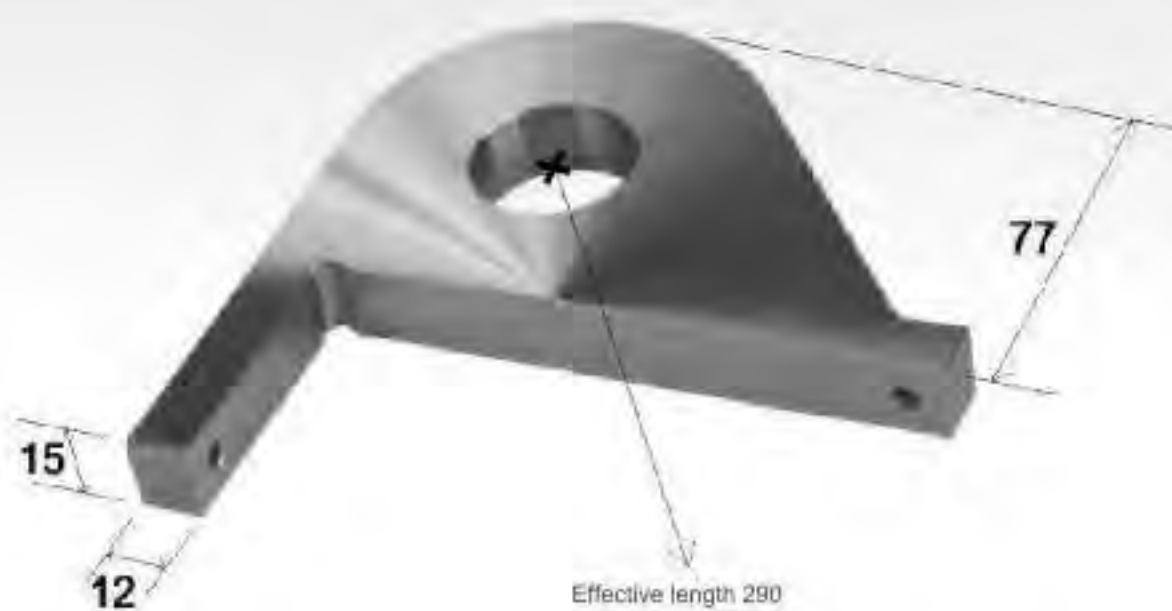

1200S mounting plate for LUXMAN PD-191A

MH-12S191A Material: Stainless steel

¥130,000 (¥143,000 including tax)

B/Bt type mounting plate

9 inch mounting plate for LUXMAN PD-191A

MH-9B171A Material: Stainless steel

¥55,000 (¥60,500 including tax) *2022.10.1 Price revised



10 inch mounting plate for LUXMAN PD-191A

MH-10B171A Material: Stainless steel

¥55,000 (¥60,500 including tax) *2022.10.1 Price revised



*The above 9 inch and 10 inch mounting plates can also be attached to LUXMAN PD-171A/AL. *If you purchase the option base MH-244S, you can install MH-900S (9 inches) and MH-1000S (10 inches). When purchasing PD-191A, PD-171A/AL, MH-900S, or MH-1000S, you can also exchange the existing base for MH-244S.

MH-244S Material: Stainless steel

¥60,000 (¥66,000 including tax)



<http://glanzl.com/>



My Favorite Room



SOUND
CREATE

SOUNDCREATE 2F/5F Miki Building Main Building, 2-3-5 Ginza, Chuo-ku, Tokyo 104-0061 Tel. 0120-628-166
 •Business hours: 13:00~18:00 (reservation required) *Please check the website as the hours are subject to change.
 •Closed days: Mondays, Tuesdays
 •Instagram: About the store @soundcreate Music only @soundcreate_music Web: <http://soundcreate.co.jp>
 The homepage is full of know-how that can only be used by Sound Create! Updated daily.



STEREO SOUND GRAND PRIX on STAGE 2022

2022.12.3~2023.1.15 @ DYNAMIC AUDIO

From December 3rd to January 15th, Dynamic Audio will be exhibiting Stereo Sound Grand Prix award-winning products. Please experience their power with your eyes and ears.

 **DYNAMIC AUDIO**

dynamic audio 5555

3-1-18 Sotokanda, Chiyoda-ku, Tokyo 101-0021

Tel : 03-3253-5555

Dynamic Audio Trade Center 1-7-2

Sotokanda, Chiyoda-ku, Tokyo 101-0021

Tel : 03-3253-1311



A U D I O P H I L E

Current status of the shopkeeper - Manabu Kaneko

I went shopping for the first time in a while!

We have resumed purchasing to Europe, which had been suspended since February 2020 due to the coronavirus pandemic.

Over the past two and a half years, the purchasing I bought records by releasing the stock (several thousand records) that I had accumulated at the store, and by using the Internet to negotiate over the computers of overseas dealers.

There were quite a few people who didn't touch it at all, so I was frustrated because I couldn't collect as many records as I had hoped, but I was finally able to fly to Germany and Austria in early October.

Today, I'd like to share with you some of the highlights.

First of all, the shop (dealer) in Berlin from.

The master here never touches a computer, so I was able to meet him for the first time in a really long time. Perhaps because the people here have connections in the music industry, there are many records that have been given away by people in the industry (talkers and important figures from record manufacturers) and family members (bequeathed families), and there are many autographs by the performers, as a feature.

This time, he gave us about 5,000 pieces in preparation. Approximately 500 titles, mainly dead stock "unopened" records (from 1960-1980, of course) and rare LPs by DGG and Eterna, which were left in a warehouse somewhere, were collected from the inventory of I was able to purchase the LP.

Next, I went to a shop in Stuttgart. I think this is probably one of the largest shops in Germany in terms of inventory and music genres (generally all genres).

This time as well, I first looked around the store and listened to my favorite records and my customers.

He selects LPs from tens of thousands of records that he thinks will be available, and that he has never heard before, but that struck a chord, and the next day he checks the condition of the LPs he has selected. The second day was especially difficult, so as soon as I finished, I went to the hotel. There was a "balan queue" situation. During my two-hour stay at this shop, I purchased about 600 LPs and had them shipped to Japan. (already arrived)

Afterwards, we moved to Vienna and strolled through several record shops. Although I only purchased a small number of items this time, the dealership I visited for the first time had a large inventory of classics, so I'm looking forward to the next time! I was told that I needed a space between my mouth.)



"GREY LIST"

This is a book for record lovers that compiles mail-order lists published by GRAY RECORD from January 1993 to January 2012. Ms. Abe, the daughter of Gray Records, was a great senior to me, and about 10 years ago she published one copy of the mail order strike I mentioned earlier.

The contents on that list are just it goes beyond product descriptions to include recording data (recording date, time, location), recording producer and engineer, matrix and stamper information, Mr. Bu's own listening notes, and the equipment used for listening and the equalizer curve adopted. It was thorough. It goes beyond a catalog and is a record library.



TOKYO Recital
Kissin
(LAN SONY)



Song Book (VOL.2)
Edition) Schwarzkopf
(EMI/Original)



R. Strauss Family Symphony
Karajan
(Ibara EMI, original version)



Bruckner Symphony No.
2 Giulini
(AIEMI/Original version)



Mozart "Nottorno et al. Mahler Symphony No. 2 "Revival"
mark
(Ibara DECCA/Original edition)



swedish serenade
salonen
(German BIS)



Pach Wind Suite (complete)
Hamoncourt
(German TELEFUNKEN)

Of course, we also have many other great performances and recordings available.

All of our stock TP can be purchased at our online shop.

At our online shop, we add nearly 100 new LP titles every Wednesday at 10am.

—take a look at our store's policy and a variety of information about Anataguma Day on our website.

Our LPs are shipped to customers after strict inspection and cleaning using a cleaning machine, so you can purchase with confidence. (Shipping and cash-on-delivery fees are free. Also, after receiving the product,

Free returns for one week. Return shipping charges will

also be borne by us.) We also regularly purchase from European countries, so if there is an LP you are looking for, please feel free to contact us.

LP GUIDE FOR

LP Guide for Audio Files

It could almost be called a science encyclopedia.

"important materials" and have kept them carefully. some of the catalogs and other books as my own when creating web pages, and I have acquired and bottom). (Of course, I still use it as a reference lot of thoughts about all of this (two books, top Published as. I have a

I picked it up right away. the first and second volumes totaling over 3,200 pages. This is an overwhelming book with luxurious binding,

than the wealth of data I mentioned earlier. san, is that there's nothing more I could ask for record. But what's even more amazing, Abe- This is the audition

It's not just a review, it's a record. Recorded background and feelings of performers and staff which it was recorded in an easy-to-understand manner. it describes the hardships and troubles of the era in I've traveled back in time. When I read the LP, records and audio. I feel like

Equalizer Carp in detail lately, both in terms of I wonder if I'm the only one who's talked about Naru Even if you're just reading it without listening I never get tired of it. yen including tax, it's not cheap at all. to it, it's definitely worth it, but at 66,000 is a recommended book. (This is not an LP record, but an old box.)



Everything I've learned recently Keith Monks's "Frodige" about record cleaning is from

and then ship them out." Cree

I clean them with Nimate NEO use a machine to clean them. on the table. Personally, I don't Personally, I don't put records Probably.

IP that hasn't been cleaned by the machine. can be said that it is still a finished product. It's the on regeneration over the past 20 years, so it machine cleaning has had a significant impact learned from running a speed store. In that sense, components as drivers and amplifiers, as I In my mind, cleaning machines are as important is a member of

Aside from that, the other day I came out of the machine. From the above liquid after cleaning LP, a jet black substance the size of a grain of rice was found.

easily and a small lump came out. Gently fold it it was, so when I put it on and pressed it, it crushed listing when a record is released. I wondered what (vinyl chloride) used in records are perfect for records, he told me that the particles of the material When I asked a friend who knows a lot about it is thought that the child may have hardened. pressing the record, do not scrape the edges of the record. shavings that flow when this happens become fine powder. After is caused by static electricity adhering to the disc. The This seems to have a large effect on the sound quality, and That's what I'm saying.

will improve. If you have a cleaning machine, Even if you clean a new LP, the sound quality I think you have that experience. (tuned) Let's take a closer look at this "particle" theory. I want to do research. (Stay



Bärenplatte store+

This month's special edition



greylist



Bruckner Symphony No. 8 Celibidache

(Japanese TOBU, limited stock)



Bruckner Complete Symphonies (1 & 2) R. Strauss | The Last Song of Four "Howl" Hiroshi

Wakasugi (BALTUS)



noman (商PHILIPS)



New Year Concert (1979) Boskovsky (Ibara DECCA/Original edition)



New Year Concert (1989) Kleiber (商CBS)



New Year Concert (1992) Kleiber (KikuSONY)



New Year Concert (1987) Karajan (German DGG)

Imported classic LP mail order specialty store

berenplatte
Barenplatte

Schallplatten Versand Antiquariat

8-4-21-11 Seijo, Setagaya-ku, Tokyo 157-0066



tel:03

Talk 03-5429-9025

(Telephone reception Monday-Friday 13:00-16:30)

Fax 03-5429-9026

Email record@b-platte.com

24h
OK

Tokyo Metropolitan Public Safety Commission Permit No. 303280207 98



IN ADMIRATION OF MUSIC



DALI KORE



STATE OF THE ART LOUDSPEAKER TECHNOLOGY

DALI KORE Suggested retail price (tax included) 8,250,000 yen (1 piece)



Contact D&M Customer Service Center 0570-666-112 or 050-3388-6801 Reception period 10:00-18:00
(excluding Saturdays, Sundays, holidays, and our company's holidays) dm-importaudio.jp/



Technical Details

Series No. 24

The pleasure of listening to record art

Tetsuya Okazaki

record

#81

Schubert: Wanderer Fantasy

Beloved by everyone, and fully devoted to the music of civil society pioneered by Beethoven, Schubert set out on a journey to the other side of the river of solitude from which he could not escape even if he struggled. Every time I visit the central garden in Vienna, I feel at least some relief that I am sleeping next to the composer I admire. I've only listened to about half of that huge collection of songs, so I can't call myself an avid Schubert listener. I feel like I'm going to get scolded by modern Schubertians, but even in the midst of many beautiful melodies, I feel an indescribable loneliness and anguish, and I feel like I'm being sucked into a bottomless abyss. This is something that other mountain composers do not have at all, and even though Mendelssohn departed at a young age, whenever he hears a melancholy melody, he is always filled with a sense of nostalgia and happiness. With that out of the way, the first piece of this article is "Wanderer Fantasy," a flood of musical notes that is not typical of Schubert. First, listen to records made by young artists Bruno Leonardo Gerber and Maurizio Pollini. The first time I heard this mountain was on Gelber's FMI broadcast on DoM. It was a board. It was my first time hearing Gelber. His vivid technique, especially his warm tone, may not be described in words.

I fell in love with the rich sound of what I would call thick keystrokes. 1st music The chapter has a considerable amount of energy from the single-headed chord, which sounds like being struck by a waterfall, and is much more confusing than Pollini's, but as someone who studied under Marguerite Long, the sound is calm and not exciting at all. The recording was by Paul Vavasseur, a master representative of EMI who recorded Munch and Delvaux in Paris. The second theme in E major (1:22~) is a momentary happiness typical of Schubert, but Gelber plays it with compassion and dispassion. It finally changes to A minor (2:25~). Immediately, the left hand plays the melody, the right hand plays the arpeggio, then the right hand plays the melody, the left hand plays the arpeggio, and from there the music becomes demonic. Although fascinated by Schubert's genius, Gerber is naive and single-mindedly presses forward. After a long, tranquil scene, the first theme returns (3:5), and then (1:15~) we reach a climax in C minor that sounds like a forest of thunder. Enjoy hitting the keys as if you were stepping on the earth. Here too, the moderate sound of Vavasseur suits Schubert. I feel like there are no balance engineers with this kind of sensibility these days. The second movement slowly takes on a lonely and serene look. Pollini also has a different approach to this song than Gelber. first day

to cut off the initial chord and kaito randomness. sound typical of Pollini. This is the perfect way Gramophon = D). It's Chopin. A bright Italian first part (Op. 10-1) of Etude (Deutsche cut through the space, reminding me of the more powerful than Chopin's, and it seems to recorded in low. It's in. To my ears, the piano is stronger recording, with "Wanderer Fantasy" RCA Italiana Studio, and this record has a slightly Chopin's Etude was recorded at my mom's in Munich, which is one of my favorites. exist, but it is said to have been recorded at Hercules palace in Munich. The studio in Rome does not Kula, a master of DG, plays Saar in the halls of a theme (1:38~). I feel like Pollini isn't up to par. recording, quietly whispering the second is a masterpiece of Us Heman's painstaking like crazy. Therefore, the stormy "A Minor" The arpeggio and melody (2:17~) are played Showing a sharp contrast. Gelber's dynamism is guided by the hissing bass (4:25~) doesn't fit into Bertade's world, but it shows a tremendous technique. wonderful sound. dazzling. After relaxing, the climax in C minor "Wandering Person". UHQCDs in recent years are especially satisfying with their movement in C-sharp minor is a majestic melody of Yamaki's song rhythm. After the dark and lonely song with no place to belong, the second ♯ which emotions gradually explode, is played by Gelber. Variations on the eerie tremolo, and the soothing Variation (1:15~) of the 2nd Piano Major, in and Kanade by Pollini (2:10~). The dreamy second variation is Po. I have a deep fondness for Rini, but I'm more fascinated by Gelber (3:30~)

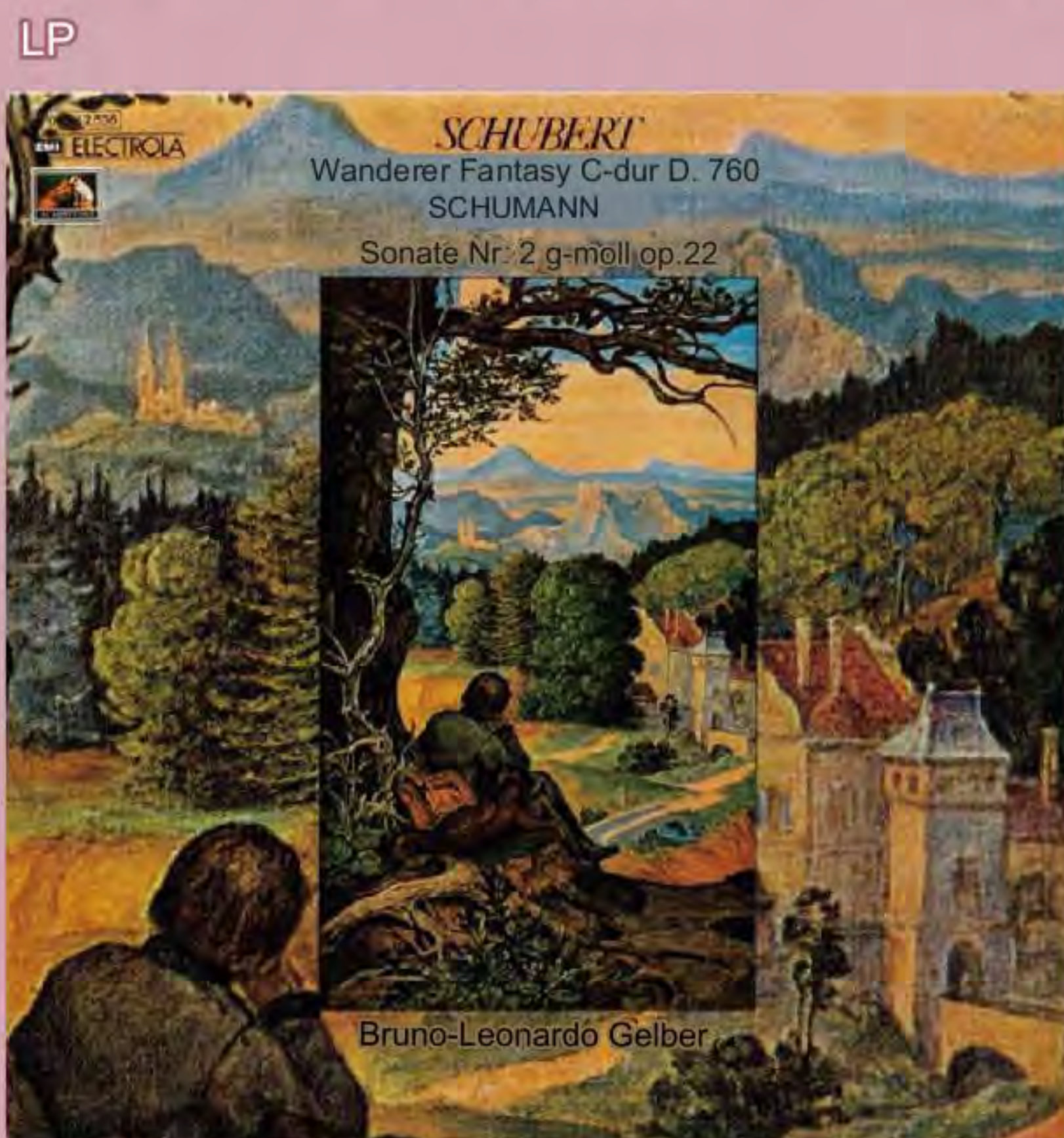

both hands in unison. The fourth variation enjoys A message appears and soon I want to leave chords, and the stream turns into a river of people. This is Pollini (4:20~) the true essence of Schuh's climax (5:16), which is built with a series of dotted end. Gelber, on the other hand, is soft even when the music is intense, showing the salons of Pollini and Geberitade. Enjoy the left hand dispersion chord at the return of the theme of the first movement from the other side is reminiscent of each fine pulver in the lower right. The of Gerba is a scherzo, and the theme of the head of the first movement is in triple time. appears. The dynamism of Pollini is heart-warming. On the other hand, the third movement

Bruno Leonardo Gelber Bruno Leonardo Gelber (1941-)

Born in Argentina to parents of musicians (Ostoria, France, Italy), he received lessons from his mother, who was a pianist, at the age of three and a half, and gave his first public performance in Argentina at the age of two. At the age of six, he studied under Vincenzo Scaramuzza, who had taught Argerich and Barenboim, but at the age of seven he contracted polio and was forced to fight the disease. After recovering his health, he performed Schumann's Concerto at the age of 15, conducted by Lorin Maazel, which gained acclaim throughout South America. At the age of 19, he moved to France to study under Marguerite Long, and was praised by the Ron as "the last and best student of all time." He won 3rd place at the Long-Thibault Riverside Competition in 1961, and has since won numerous awards. He has established a powerful atmosphere with Peter Peter and Brahms at the core of his orchestra, which has won numerous awards, and has also given excellent performances to Schubert and Schumann. First born in 1968. In 2011, he held a tour to commemorate his 70th birthday throughout Japan, and is also known as a parent. Brahms's Piano Concerto No. 2, which he recorded in England with Rudolf Kempe, is highly regarded as a masterpiece, and he has shown the state of monologue with mature piano since his star period, such as "Variations and Fugue on a Theme of Handel." Ta. (Okazaki)

schubert
Wanderer Fantasy,
etc. Bruno Leonardo Gerber (p)
(EMI ELECTROLA 10063-12 536)

CD



Romantic Sonatas
Schubert: Wanderer Fantasy, etc.
(Toshiba EMI CE25-5854-55)

it is. -'s not-too-sharp piano is like Schubert's simple person. It's telling you what

it. " The finale begins with a fugue, followed by an incredible arpeggi. Pollini has a great sense of dynamism. Schubert said, "Let the devil play note of the fugue, everyone can't help but think of the so-called mi episode. that makes you feel like you're watching Kelangel's David. From the first a melting pot of excitement, and then approaches with a tense majesty dazzling and brilliant arpeggio sound (1:20~) invites the listener into is moving forward with great enthusiasm. The technique is visible, and the of taste, this finale is notable among all of Pollini's DG recordings. Meaning scene commemorating Gelber's Arna Studio. In terms splendid Pollini, this finale is said to be a famous he feels as if he is stepping on it. In contrast to the recorded it, he plays the piano with such a firmness that Although he was only 3 years old when he world. Instead of being low-key, it's a bit of an initiative. the lower left and the right hand is an adult art come in is a masterpiece. The thick, mellow sound in arpeggios come in, and the part where the arpeggios style. Two years later, Rudolf Kempe and Royer's Le Fenol and that Brahms Concerto No. 2 (E lions, I am on the way to recording MI), listening to the famous performances by the two young Budokan, I happened to pick up a Rubinstein record. After when Takumi Oyama came to Japan and was at the recorded in their respective anniversaries. In 1965, the commemorative edition of Young Lion's visit to Japan, Person" fantasy, which I won't go into too much about, but The most different impression I got was the "Wandering

but it didn't sound like a very technical challenge... shoulder strength Pollini and Gelber out, scattering notes effortlessly with a dignified stride, it was over in the blink of an eye. He started playing smoothly with sweaty hands and exclamations of admiration, but I couldn't wait until calm look on his face, and at the same time, I was listening to it with my heart warm. Recording I was a little taken aback by the calm and recording, and has a slightly round but ideal finish. It makes typical of RCA during the heyday of analog Like Rubinstein's piano, it has a very rich, happy sound - Belt friendly. And this record is Polly

LP



schubert
Wanderer Fantasy,
etc. Maurizio Pollini (p)
[Polydor MG2483]

CD

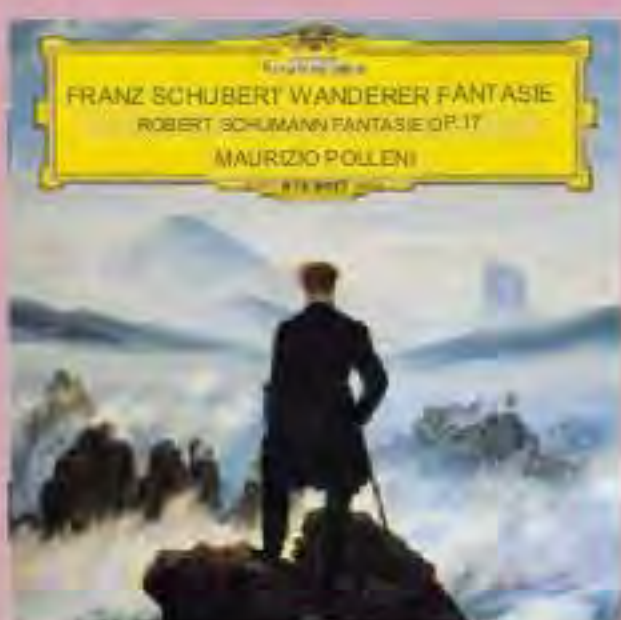

[Universal Music UCCG41085]
*UHQC

Maurizio Pollini Maurizio Pollini (1942-)

in Milan to an architect father and a musician mother, he studied piano from the age of five with Carlo Rob Ti and others. In 1957, at the age of 15, he won 2nd place at the Geneva International Competition, and the following year he won 2nd place at the same competition with no first place. Winner of the 1st Bozzoli International Piano Competition in 1959. In 1960, at the age of 18, she won the 6th International Chopin Piano Competition. The chairman of the jury, Arthur Rupenstein, called him "more skillful than any of the judges here," and for the next 10 years, he left behind a glittering career and focused on performing. He continued to study under Arturo Benedetti Michelangeli. In 1968, he returned to international tours, and in 1971 he resumed recording for Itz Grammophon, including Stravinsk's "603 Movements from Petrushka", and became the darling of the times with his perfectly ignorant masterpiece of Schapen's "120 Etudes" (1972)*. First Mizuguchi in 1974. From Beeto Venn, Schubert, Schumann, Chopin to Webem, Boons, and Nono, the time of the sun. His brilliant sound, overwhelming technique, and clear and deep interpretation made him the best pianist of our time. became. In 2014, completed the recording of Beethoven's complete sonatas. Even now, at the age of 80, he continues to challenge himself to reach the pinnacle of pianism. (Okazaki)

recorded in the same studio in Rome as D. actually his true feelings. The piano was to fit into Poly Brother Records and it's Competition It's interesting because it's easy anyone else here." Ni wins the Chopin was clear. When he does that, he's better than was exactly as it was, and Rubinstein's goal Wanderer's Fantasy. I realized that the music of praise, but when I listened to the I was at a loss after listening to his words waiting for me," he said with a smile, and I thought even younger. "Finale, there's no path impression that their arpeggio skills are this great song sound effortless have the far higher level, but the old men who make the master's skill in playing the chords is at a Uno is an honest feeling. It is said that There's no end to the fun of listening.

LP



schubert
Wanderer Fantasy,
etc. Arthur Rubinstein (p)
(Japan Victor SHP2432)

CD



(RCA VICTOR/BMG 09026 63054-2)

Arthur Rubinstein

Arthur Rubinstein (1887-1982) Born in Lodz (present-day Poland), he was called a child prodigy at the age of four. On the recommendation of Joseph Joachim, he went to Berlin and performed with an orchestra at the age of 13. In 1904, he went to Paris, where he played Saint-Saëns's concerto and became a darling of the music world. When he debuted in the United States in 1906, technical mistakes were pointed out in his career, which he had built on his own, and he left the stage. In 1910, he won the Anton Rubinstein International Piano Competition. In 1912, he made his debut in London. During World War I, he traveled to Spain and South America as an accompaniment pianist for Eugene Ysaÿe, and his works there became part of his repertoire throughout his life. In 1932, he began working in secret again, refining his technique. It is said that he was shocked when he heard Vladimir Horowitz, but since his return, he has reigned at the top with his brilliant technique, unparalleled brightness, and music with a rich scale. Even as he grew older, he continued to play the piano with a vast repertoire, including Sipsan, Schumann's romances, and Beethoven's elegance. Retired from the stage in 1976. On his last recording, Bra Mus' Piano Concerto No. 1, he performed at the Grand Manor with Zu Bin Mehta and the Israel Philharmonic.

It sounded incandescent. He will forever be the king of the piano. (Okazaki)

Record

#82

Schubert: String Quartet No. 14 "Death and the Maiden"

listener. Schubert's genius is most evident in his songs. masterpiece that captures the romance and torment of the which is based on a poem by Matthias Claudius, is a is gouged out by the Grim Reaper. "Death and the Maiden," death is eternal rest. It begins with a D minor chorale and The girl's pleas for him to die are in vain, and she says that

and taken away to the other side. The original D minor melody is the second song. Already used in Kenso's Variation Mountain (the quartet is in G minor), it is stringed indulgence, where he often suffered from poor health and was conscious of death. Quartet D810 is called "Death and the Maiden", which depicts Schubert's state of self- This is a terrifying piece of music created by a wandering mind.

When I first started listening to records, there was a lot of music on this mountain.

was no definitive version of the Toshiba G Teleo recording, and the Capet and spirit. The SP reprint of , was said to be the best record of all time. There impressed when he listened to Bush on Columbia's DX R record. Dedicated overwhelmed by the full-fledged performance filled with passion. Capet was deeply but it was no longer in print, so I listened to it on the reissue and was this strong individuality of M. The record was famous for its powerful reprints, was the first time I heard it. The feverish romance was unparalleled. Even now, can compete with the recordings of Westminster's Wiener Konzerthaus. It filled with a luxurious fragrance. After the war. I don't think most records Monaural Smetana SQ (Supraphon) SQ Quartet (SQ) monaural record, still has the best viola in the atmosphere of the Libensky era.

good, but of later years. I also listened to the overwhelming light. Smetana by Zoltan Seikei of the Hungarian SQ. Recorded in 1954, neat and of course still listen to the second movement. Even Beethoven is not at his best. Sung Bosco, The middle period of the Musical Saint really touched my heart. I SQ (CBS, monaural), which was as exciting as the Vienna stereo generation's something was missing. I wasn't as impressed as the latter half. Budapest was overwhelming. Ski's Vienna SQ (Decca) had a perfect mood, but breath away, but it is too functional for European players. The record (RCA) performance, but in Italy it would be more like "Rosa's technique takes my Westminster Smunde. Vienna Konzerthaus S Thalia SQ was a beautiful match for leader Anton Q's Yamamoto

performance and recording were a good thought Camper's energetic and passionate at how realistic the recording was. I Kumozu Zon, a greedy listener. I was surprised (RCA). Then came the up-and-coming the commemorative Lieveland SQ They came to Japan in 1978 and released



Schubert: String Quartet

No. 14 "Death and the Maiden"

Sean Konzerthaus Quartet LP

(| ㊦ VOS3009) Westminster

*1960, Tokyo recording

LP



Schubert: String Quartet

No. 14 "Death and the Maiden" and others

Smetab Quartet (Supraphon ALPV308) *MONO

LP



Schubert: String Quartet

No. 14 "Death and the Maiden"

hungarian string quartet (VOX GBY12.520) MONO



Eternal Master Series
Glorious Capet String Quartet-6
Schubert String Quartet

No. 14 "Death and the Maiden"

and others Cabet String | ㊦

Quartet (Nippon Columbia DXM119AX)

*MONO

CD



Adolf Busch's art
Schubert: Quartet

No. 14 "Death and the Maiden" and others

bush string quartet (Toshiba EMI TOCE6781-97) *MONO

sense of power. In any case, it is an ideal record for both performance and recording. first movement of the first movement in D minor, it was perfectly balanced and had a light formed (many years of recording), but it is natural that they are youthful, and from the is from Juilliard SQ (CBS) around this time. It has been six years since the band ensemble is also extremely high, and the sharp expressions are always included, and this by the range of sound, which has already matured for several minutes. The accuracy of the is more humane and less sensitive than Alban Berg's later work, SQ. I'm surprised to sing the tenth theme in a refreshing and relaxed manner. It's a blend, and the music gifted educators such as Kagaramian and Rose, I still don't know what to do. It's also nice second. Feels similar to Budapest SQ. And even though I learned from American charm of the cello quartet, with Weilerstein on the first violin and Juilliard SQ on the the viola, the harmonious and refreshing sound of the sailor on the violin, and the In addition to the inclusiveness of the two, the music is always centered around Martha on

LP



シューベルト:弦楽四重奏曲第14番「死と乙女」、他
クリーヴランド弦楽四重奏団
(RCA ARL1-0483)

LP



(RVC RVC2056)

ストロギン・カツツが大きな役割を果たしているところにある。チェロのカツツの夫人であるこの女性ヴァイオラ奏者の、太く力強い響き、あざやかな技巧と存在感は並大抵のものではない。ブダペストSQのボリス・クロイト級と言ってよい。この素晴らしい名演は何故かCDになっていないので、楽譜の小節数で記すと、開始早々の15小節のシンコペーションからヴァイオラがグツと右手に現れる。第二主題(61小節)を二挺のヴァイオリンが弾く後ろに三連符でつけてゆくあたり、クロイトを想わせる。強靱な四人のユニゾンで聴かせる160小節からの盛り上がりはブダペストSQのラズモフスキーを聴くような興奮がある。第2楽章は豊かな歌を聴かせてくれる。変奏曲はまったく円熟の藝境であり、第二

変奏(129小節)の夫君カツツのチェロの歌はガルネリSQのデヴィッド・ソイヤールかブダペストSQの兄シュナイダーを彷彿させる。がらりと変わる第三変奏(73小節)のフォルティッシモも綺麗な音色で揃う。第3楽章のスケルツォもフレッシェな音で明確だが、温かく機械的でない。これほど四つの楽器のバランスが取れ、響きが立体的に見えるレコードも珍しい。四人がひとつの楽器と化すカルテットの理想郷を実現している。フィナーレ。シンコペーションの効いた主題と伸びやかな副主題、ふたつの複合からなるロンドが、後半に向かうほど翳りと火照りを増してゆく。ロンド主題が心地よいテンポと絶妙なバランスで弾かれた後、副主題がユニゾンで出る88小節の爽やかな意気

Cleveland Quartet

クリーヴランド弦楽四重奏団

1968年、ガラミアン門下の第1ヴァイオリンのドナルド・ワイラー・スタイン、第2ヴァイオリンのピーター・セイラフがマールボロ音楽祭でヴァイオラのマーサ・ストロギン・カツツ、チェロのポール・カツツと出会い、翌年クリーヴランドで活動をスタートさせた。ニューヨークに移り、州立大学を本拠として活動。RCAからブラームスの三曲でレコードデビューし新星として大評判をとる。パーバー、アイヴズの2番、ハイドンの「ひばり」、「五度」やシューベルトの「死と乙女」、モーツァルトの「アダージョとフーガ」さらにベートーヴェンの後期を録音。並外れたテクニックに加え、溜めの利いた歌いまわしを備え、ことにマーサ夫人のヴァイオラは圧巻だった。1978年に来日。この世代のカルテットの中ではブダペスト張りの大人の藝風を聴かせたが、1980年ヴァイオラがマーサ夫人からアタール・アラッドに代わってからは、上手いが歌心と凄みが薄れた。1987年に第1ヴァイオリンがウィリアム・プレウシルに代わった。デジタル時代はテラークにベートーヴェンの全集などを録音。(岡崎)

measure 110. It's also nice that Sakae's breathing is realistically recorded, and the excitement increases, including cello, viola, and violin from to go. After the relay triplet opens up, high-level techniques fly around, I'm going

From bar 228, after a rolling decline, a well-reserved note appears.

finally removed, Mrs. Katz's thick viola appears from the ensemble (236 Budapest SQ. At around bar ~238), the stereo recording of this song is builds up to a level that makes you think it would be played by the prestissimo of the coda and the sub-theme at measure 416, the climax is moving. He effortlessly handles Schubert's flood of notes. After turning into sound as a living creature (from bar 707)

amount of on-mic, and the excitement of Kawato Le Mi Fa So F is perfectly captured with just the right quartet records. From bar 727, the moment of straight and runs away, which is unique among all the brilliant A Fa Mi Ra, which plays the fushi costs. The figure plays in syncopation and is the same as Written. I want to make it into a digital disc at all I want to wish.

In conclusion, Ama contrasts with Cleveland SQ.

(DG) of the Deus Quartet as an analog record from its heyday. In 1981, Amadeus recommends the digital recording the release of a massive compact disc, that is not the would be normal for them to re-record in anticipation of gaps in style and shaky moments in tone, and although it albums are already in their late stages, with occasional I was getting fucked. However, the quartet's Amadeus at the old Iino Hall, Noh is not all about advanced techniques. Two years later, Noh performed for the last time in Japan

I listened to it and it was an amazing stage just like this record. Ta. It must be the afterglow of Amadeus, but it's not dull at all. Vienna. That's it. In the second movement, Brainin's violin has a thin sound, but still. smoked silver cello. It seems like he is reminiscing about his younger days in see in the paintings of John C., and as I was listening to its sexiness, I heard Lovett's I thought of it as having an old, relaxed atmosphere, like the one you third variation features the familiar Amadeus with very large gestures. becomes Fuus. This performance reflects on their life as a quartet, and the anger. The same goes for the first movement and the Scherzo, but it Inaan again hits the body regardless of form. It is said to be a wave of



Schubert: String Quartet No. 14 "Death and the Maiden" and others Amadeus Quartet (Polydor 28MG0567)

CD



(Deutsche Grammophon 410024-2)

Amadeus String Quartet Amadeus String Quartet

After the war, Norbert Prenin and Peter Sidorov from Vienna, and Sigmund Nissel, an Austrian born in Munich, were released from an enemy camp in England and studied under the famous violinist Max Rostal. Through Rostal, they met Englishman Martin Lovett and debuted as a string quartet in 1948. Initially, they had a soft Viennese style, but as they became active internationally, including with Eikawa, they changed to a more massive style, which led to Haydn, Mozart, Beethoven, Schubert, Brahms, and other German-style repertoire, which established his reputation. On the other hand, his passionate performances with a touch similar to oil paintings, which can be heard in Dvořák, Buyakovsky, and others, also entertained enthusiasts. They remained a constant member for 39 years, but due to Sidron's sudden death in 1987, their activities as a quartet ended. Recordings have been made on Deutsche Grammophon and various other music labels. The size of Verdi's amazing energy is unparalleled, but the Amadeus Quartet is unique in Haydn's "charm that spills out in the dynamic spaciousness." (Okazaki)

Unusual skill in collecting. CDs are good, but you can enjoy the realism of analog music as if you were feeling Brainin again. The excitement I heard at lino Hall and Retsu Nichi comes back to me. Rough sound, dog-like scale, old

Spring. My sincere thanks to Wolfgang Mittelerner for capturing the shining Yellow Temple so beautifully.

Record

#83

Schubert: Piano Quintet "Trout"

When Schubert was 22 years old, he was invited by his close friend, the singer Vogl, to visit Paumgartner, a wealthy mining engineer in Styria, northern Austria. Paumgartner, who liked Utayama's "Rumours," asked him to write a quartet using that melody, and Schubert created a piano quintet by subtracting one violin from the string quartet and adding a double bass.

This arrangement has already been written by Hummel, and is said to have been ordered by Paumgartner, who was an excellent cello player, but the melody of the "decoration" is a variation of the fourth movement, and it is music that only Schubert could have created. A sense of community

was created. The first record I heard was from the Budapest Quartet, with my brother Schneider playing second violin, and Julius Lev.

There was a quintet (CBS) with Non joining on the double bass and Holshofsky on the piano. One game, a dry sound that is recognizable as CBS, and a slightly raw on-mic stereo recording. The members of Budapest, who looked stern in Beethoven's performance, seemed unusually relaxed. Horsovsky plays the piano in a homely, dispassionate manner, and works with the ensemble in a way that only shows his face in this particular key point. For example, in the first movement, when the violin and piano are playing a certain theme, the viola and cello are clearly playing the rhythm with blank faces, while the double bass is playing in the background. There is. Horsovsky wrote the famous 4th movement

Even in the variation of "Rumour", he plays a gentle piano and enjoys Budapest in his everyday clothes. As Masaki Oki said, "Although he does not greet Schubert in the slightest kind, this is the performance of someone who has a deep respect for him." The tone is unfriendly, but it has an indescribable charm. The performance, in which Poshta joined Panenka on the piano and members

of Smetana SQ, who were the face of Czech Supraphon, has long been considered a representative record of "Sen", and I would still like to call it one of their best records. The

sophisticated taste of European interior music is exceptional, and it is always at the height of the world of chamber music. Panenka's piano plays are unusually skillful, with the solo ♯ and the accompaniment having just the right amount of flavor. The trio of Smetana are always changing and meticulous, and the contrast between Novak's slender violin and the firm sound of Kohout's cello is stomach. Shukamp's viola



Schubert: Piano Quintet "Masu", etc.
Miko, Chislav Horsovski (p), Julius Levin (Cb),

Members of the Budapest String
Quartet (CBS/Sony SOCL251)

group excels. Its matte tone is also attractive. Theme from viola to double bass when the piano is handed over and the music expands, is where the Smetana worth it to see how these sounds come together as one. The second movement, courtesan in the third movement seems casual but has an exquisite balance. It's want to experience it in analog form. The dialogue between the skeltz and the between the members, especially the trio's skill and beauty. I definitely know it, I end up feeling like a dream. The highlight of "Tor" is the sense of unity to the movements of the Panenka peer in the third variation, but before I he fell behind after the fifth variation. Too up and down. I brace myself to listen trout jumping on the river surface in a wonderful chamber music scene. And The sound of the Kohout cello. You can see the

It is the color of Finan is also like this.

The ensemble is irreplaceable.

Speaking of Schubert from the musical capital of Vienna, U and members of Baan Konzerthaus SQ. is also a mono version of Badura Skoda, Westminster Lili SQ, in addition to Skoda, there In addition to the members of stereo recording, perhaps a dramatic change. in a warehouse in good condition. There is a ^{Wahlerg} by the female producer of MCA Victor from Japan, but Kotonno was produced it was called a label that had drifted away that I dug. In terms of quality, in the 1990s CD. Ant I think the best one is the denosk two recordings have been made into one Konzer, led by contrabassist N Cumber. The House SQ members and the Vienna

The Skoda version of Hermann and the piano is Schube.

of Rulo's performance was considered the utopia German, but Camper sound Surprisingly passionate, with a particularly sweet 1st movement Lee of the heat is very impressive, that, the reenactment part board. In addition to is included in the Smetana

Smetana Quartet Smetana String Quartet

Formed in 1943 by members of Professor Micka's class at the Prague Conservatory, it debuted as the Smetana String Quartet in 1945. Neumann, the first viola, turned to conductor, and the first In 1956, Lipenski, the first violinist, took over the viola, and Jorge Novak became the first violinist. The stable members are Lubomir Kostecki on second violin, Škamba on viola, and Antonin Kohout on cello. From around

1950, he wowed fans with his code performance, and gained worldwide fame with his 1957 tour of the United States and Canada. Items) Smetana, Dvořák, Janáček, Haydn and Mozart of the mountain school, and even Beethoven, who was called the treasure of the Blach music festival, to Romanticism, modern Russia, and Eastern European repertoire, all with perfect construction ability. He became a sensation throughout the world with his ensemble, which was known as "Neri-like". Retired in 1989. He has a huge number of recordings in Czech Republic's Supraphon, Germany's Enctorola, America's Westminster, and DENON. (Okazaki)

Jan Panenka | Jan Panenka (1922 - 1999)

Born in Prague, studied under František Makshiboun at the Blaha Conservatory. He then studied with Pavel Serebryakon at the Leningrad Conservatory. Debuted in Prague in 1944. He won first place at the Smetana International Competition in 1951, and since then has been active as one of the Czech Republic's leading pianists, and has been widely active as a soloist (piano solo, chamber music, concerto). In 1972, he recorded Beethoven's complete piano concertos. He was an outstanding master of chamber music, making use of his wam and clean artistic style. From 1937 onwards, he gave many performances as part of the Sku Trio (Moon with cellist Josef Huff, and his collaborations with the Smetana Quartet brought bliss to enthusiasts. In 1980, due to a finger injury, his career as a pianist was in doubt, but he made a successful comeback and continued to show a delicious lack of enthusiasm until his later years. He first came to Japan in 1959, and has visited the country many times since then, giving master classes at the Kirishima Music Festival. As for the Souk Trio, I will never forget Smetab's Piano Trio and encore "Souk) | Engie" at Ueno Bunka Kaikan. There are recordings of both songs on Splatfan, but I can't think of a better performance. The Panenka name will be immortalized forever as a signature for matching items. (Okazaki)



Schubert: Piano Quintet

"Masu"; etc.

Jan Panenka (p), Františ, Ku Pošta (Cb), member of the Smetana Quartet (Supraphon 50174)



(Nippon Columbia 28C37-39)

CD



Schubert: Piano Quintet "Mas" Paul
Badula-Snieda (p), Josef Hermann
(Cb), members of
the Win Konzerthaus Quartet Otto Rüm
(Cb), members of the Parilli Quartet
(MCA Victor MVCW19001) Mono/Stereo

CD



Schubert: Piano Shigeyama
Masu", others
Emil Gilels (p), Rainer
Zeppelitz (Cb), Amadeus
String Orchestra Yotsuguchi
(EMI 34623)

What is Beethoven's concerto?
Yama No. 4 and "Emperor" remain.
did. Like-minded members
female pianist played a
and Bosco's piano. This
bit of Curzon's charm
of Vuisky with a little
I can hear the sweet sound

don't think "decoration" suits a pianist of the Ittuso type. So
is Ginglis, who is a member of Amadeus SQ and I
I put on it feel like being in the sun, and the only exception
would like to mention here the first recording (EMI) with
Futswiper Menuhin. The variations on the DG album that
Menuhin. However, in terms of Amadeus SQ's "decoration", I
variety of roles, including accompanying her brother

second movement is as refreshing as the sun leaking through the young leaves.
and the third movement are full of momentum, and the trio has a local flavor. The
Helm. The variations are full of emotion, which is unique to camper discs. Vio piano
of the later Walter Weller SQ. The warm tones of Erich Weiss in A are also nice. Son
temperament passed down through two generations. Art Weiss was the viola player
to Walter Bariri's dog sounds. It's a pleasure to hear the origins of the Viennese
be romantic. However, there is. As for the stereo recording, it's a pleasure to listen
and spaciousness, while Skoda's expressions were heartfelt, full-bodied, and tended to
recordings, which had a very three-dimensional sound quality, were full of flavor
doesn't suit Bariri's hot air, which is introspective and pretty. That's why the early stereo
and piano, are something I would like to listen to carefully. It's too much, and it
monaural recording. Clifford Ka's variations, such as the dialogue between violin
Octet, who were not active in recording, had a distinctly homey feel and was a camper
One of the records (Decca) by Curzon and Boskovsky, members of the Vienna
Knappertsbusch and the Vienna Philharmonic are known for their quality recordings.

LP



Schubert: Piano Quintet "Masu"
Hepsipa Menuhin (p), Edward Ment (Cb),
Amadeus Quartet
(Angel S35777)

CD



(Toshiba EMI/Shinseido SAN48)

impression. Members of Amadeus SQ before becoming titles, especially the leader "Death and the Maiden", by Pleinin on the piano and Sidorov on the viola, left an joyous tones of Cleveland SQ (the first member), who was recommended in popular record that was released was Philipp, who collaborated with Brendel. The is probably the "time" of the Steyrs album. Double bass: Van Denmark. The most has a symphonic approach that has received rave reviews since its release, and and leisurely group music has completely increased its expression and scale. It 40 With the help of the rare Schubertian composer, Brendel, the technically excellent record, and as expected, the recording was by Philips, which is a wonderful thing. fascinated by Radoka Iku's back, Panenka, and Smetana records, and I found this it, and the code is not very impressed with just an evil thing. I'm in the Prendels. But that's that is clearly contained masterpiece has a deep charm togetherness, this lovely addition to the feeling of Panenka and Smetana. In beloved records include this brilliant record, his performance. Along with out to be a great of the audiophile turned beautiful Tansaku performance on the island, the the time of bliss came true will come. When - the late Levine.

LP



Schubert: Piano Quintet "Masu"
 Alfred Brendel (p), James Van Demark (Ch), members of the Cleveland Lustful Quartet (Philips 9500.442)

CD

Alfred Brendel
 Alfred Brendel (1931-)
 Wiesenberg in North Moravia (currently 0)
 Born in Loučna (Czech Republic)
 Ru. Studied piano from age 6 and moved to The Dump with his parents
 In 1943, a group of people spend their days suffering during the war.
 Moved to France and studied piano and music theory at the local music conservatory.
 He studied at the Conservatory in Vienna in 17 years, but this
 During that time, I was mostly self-taught to play the piano. 1948 Gura
 First recital in 1949, Pusoni Riverside Concert
 Coolly won 4th place and made concert debut in Vienna one. With Jörg Demuth and Paul Baduraskoda
 Together they are known as the Three Young Crows of Vienna. Same work
 See Edwin Fisher's Master at Lucerne
 ...participated in classes and has been active internationally since the 1960s.
 Expanding his career and opening a store in London, Beethove
 Bach, Haydn, Motto
 Philly from the Sardo to the Romantic School to the New Viennese School
 He left a shadowy recording on his laptop. When with a transparent tone
 So precise that it takes your breath away, and extremely dynamic.
 He captivated the audience with his pianism. Cormorant at the end of 2008
 Retired from the stage after performing at Vienna. (Okazaki)

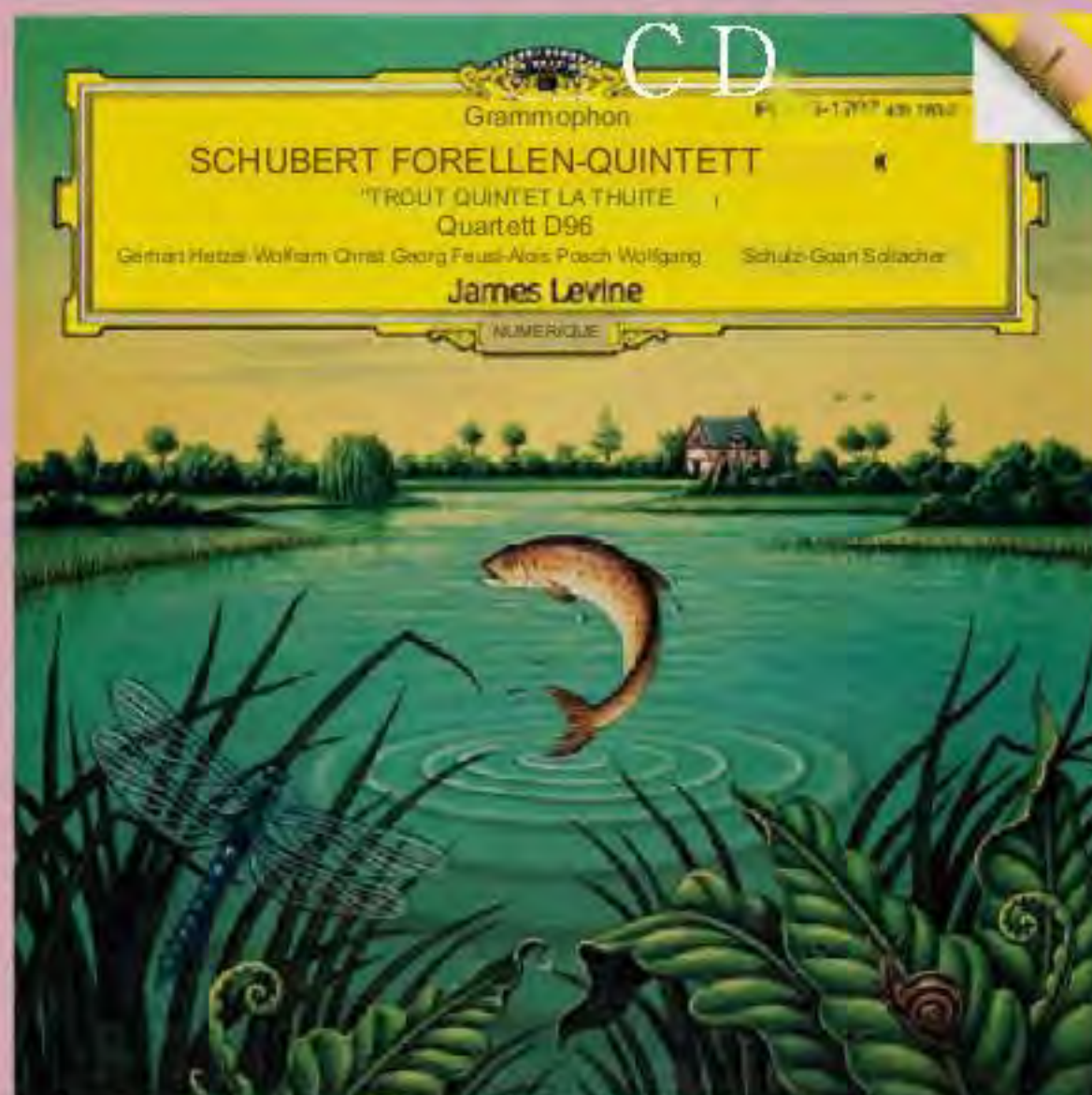

Schubert: Duet for Piano, etc.
 James Nwein (p), Gerhard Hetzel (vn), Wolfram Christ (va), Georg Faust (ve), Alois Posch (Cb) (Polydor POCG1707)

Fitz, Hetzel of the Vienna Philharmonic, Christo of the Berlin Philharmonic the DG album recorded with the band also has a fondness for it. Boskovsky, Orchestra was born after the Vienna Octet, which was led by in high school, and Scotch. Gerhard Hetzel eventually became the leader. The Vienna Chamber Kreutler, and the piano. The "rumors" I heard live on stage were Hetzel, Stronk, and the Viennese style, with Cicchi, impressed by Demuth, who was truly in Thoughts for the River. I was so However, I thoroughly enjoyed Hetzel's I would like to mention this DG board.

listening mirror

Serialization

President Kennedy's 45th birthday celebration was held at Madison Square Garden in May 1962, when Marilyn Monroe appeared on stage as a surprise and sweetly chanted "Happy Birthday." The scene where he sings "Mr. President..." is very famous. However, it is not well known that the accompaniment pianist at that time was Hank Jones. It has not become.

As time passed, Yamaguchi asked Hank Jones himself about what happened at that time. According to them, the surprise had been carefully rehearsed in advance. You repeated the same thing 13 times," Hank said, laughing and patting Shiraburi's knee. At the end of the day (note: Hank is not mentioned), he said happily to Fumi, "The White House didn't take over my salary at that time!"

Why I like bananas Because there's no bones--Hank Jones

115

Shoji Sugawara, owner of the jazz cafe "Pacy"

he laughed. It seemed like a joke, but that seems like a likely story. I heard the door open even though it was closed. The courier guy delivered the package. Inside are two LP discs. Unfortunately, this was supposed to arrive today, so while I was waiting, I was thinking about the story of "Happy Birthday Mr. President." The breakdown of the two LP discs is East Wind. One of the label's reissue titles is "I'm Old Fashioned/Sadao Watanabe with the Great Jazz Trio." The other one is "The Great Jazz Trio at the Village Vanguard." As you know, this is a completely limited production edition released by Sten-O-Sound, and is not a sample edition, but the actual item. At first glance, it seems like a pretty impressive mountain. The printing and construction of record jackets. I thought so because this finished product is I put it in the jacket that had been sent to me before.

There are a total of six different types of lacquer discs. There were two test presses stacked on top of each other on the table. When I looked down at the finished product, I realized that I could no longer handle it, so I gave up. After calming down, I went through both sides A and B. I listened to it. The sound of the original version that I was aiming for. Of course, it's normal for there to be slight differences, but it would be rather creepy if they were exactly the same. We must admit that there is a gap of nearly 50 years between the production dates. I was relieved because the sound of this finished product was the best Xiaomi I had ever heard in a test. This reprint may be a better choice for modern speaker systems, as it has a slightly more crisp sound than the original. Please rest assured that the quality of the performance will not change. —Hatsuan (who is Mr. Ito Yasochichi), please give me a try with this.



Photo © S.S. Swifty

Ei Otaki Omnibus 50th Anniversary Edition

STEREO SOUND 278

Otaki Ei!

Shinichiro Kobayashi

Eiichi Otaki's first solo album, "Eiichi Otaki," released in 1972, has been reprinted as a 2-CD set as a 50th anniversary edition. Unraveling the hidden charm.

Who is Otaki?
know,

A masterpiece of skill

You can enjoy it

In this magazine, I have collected a huge number of I've introduced the works of pop music, and I've talked extensively about the quality of audio products in the past. The reason for this was that I felt doubts about the previous situation in which this magazine seemed to have completely ignored rock and pop music, which overwhelmed classical music and jazz in terms of record sales (small population), and I started working on high-end audio as well. As someone on the music criticism side, I had to confront the editorial department.

Of course, in the rock-pop field, there are many works that are difficult to satisfy from a so-called pure audio perspective. However, Eiichi Otaki, who has recently devoted a large section of this magazine to introducing the special reissue, has been deeply interested in the essence of his own creations and the sound creation that contributes to musical grooves from an early stage.

I've been pursuing it. In particular, his first solo, "Eiichi Otaki," which I will be discussing in detail this time, is not only rich in musicality, but also allows you to enjoy the essence of rock and the tension that is unique to a singer-songwriter work in audio terms. It is a masterpiece among masterpieces.

in the title
How it was named
"Omnibus"

This all happened during the recording of "Kazemachi Roman" (November 1971). Even though Happy End belonged to the indie label URC, Mitsunori Miura of King Records, who was deeply involved in its recording for various reasons, approached Otaki about pursuing a solo career, and Otaki decided to pursue his first career as a solo artist. The single "Koi no



bass (December 2017) released on drums, Kisha Poppo on shift of Otaki. Haruomi Hosono is caroled in the unusual Le King and Gerry Goffin's work

Good rock and roll. just, and was just a complete collection off of Happy End, didn't feel Then, the second single, "Sorabu seemed to be that of a solo act

like a single, "Kujira" by Ikai, a spin-off for the first time. of Toll's Method. a result, the flow Head to Rubam. As

Eiichi Otaki Omnibus 50th Anniversary Edition

Eiichi Otaki (Sony SRCL12345~6) ¥4,290 (tax included) 2CD

recorded music

Disc 1

- 1 Thoughts
- 2 That's not me
- 3 Love Train Poppo Part 2
- 4 finger cut
- 5 bottle
- 6 May Rain
- 7 Uraraka
- 8 Atsushi's fault
- 9 Overslept
- 10 Watercolor town
- 11 messy hair
- 12 Flying Whale
- 13 Let's make the most of this love!

Disc 2

- 1 Love Train Poppo (Single Version)
- 2 That's Not Me (Single Version)
- 3 May Rain (Single Version)
- 4 Binbou (Himadarake version)
- 5 Uraraka (Intro Drum Version)
- 6 Atsuna no fault (full size version)
- 7 Flying Whale (Hiano Intro Version)
- 8 Troubled Hair (Outro Strings Version)*
- 9 Binbou (Hanihole version)*
- 10 Atsushi no Sei (instrumental version)*
- 11 Atsusa no Sei (rehearsal version)*
- 12 That's not me (Album MIX-2)
- 13 Omoi (UNDUBBED VERSION TAKE 1-4)*
- 14 Make it! This love (cassette version)

Participating musicians

Haruomi Hosono, Takashi Matsumoto, Shigeru Suzuki (Happy End)
 Hayashitsu University, Masataka Matsubaya, Bundai Nunotani,
 Keiichi Suzuki, Minako Yoshida, Singers Three, Yuki Komazawa
 Yoshiyuki Noji, Ritsuo Uemura, Mitsuo Ikeda, Jimmy Takeuchi
 Masanaga Harada, Hiromi Sano, Masaaki Sano, Teruyuki Fukushima

Over 60 pages

Includes deluxe booklet

- Eiichi Otaki long interview (until "Ei Otaki" was created)
- "Interview postscript" by Manakusho Yuasa
- Liner notes of Ei Otaki

Engineer: Kinji Furuno

Mastering Engineer: Tetsuya Naito

The 50th anniversary commemorative edition of Eiichi Otaki's solo debut consists of two discs, with Disc 1 adding the second single "Flying Kujira", which was intentionally removed from the album, and reorganizing the original songs in the order that he envisioned in 2012. He also performed a clear version of "Let's Live! This Love," in which he shyly imitated Elvis Presley and made the sound sound like a radio cassette player. Disc 2 is a comprehensive compilation of different versions of each original song. The remaster is also 24-bit, and you can enjoy it like a maniac, including the super detailed explanation, but if you are a beginner to Otaki, it is wise to thoroughly enjoy Disc 1 first before proceeding to Disc 2. The surprise and satisfaction doubles with each step.

(Shinichiro Kobayashi)

大滝詠一

『大滝詠一』の 主なパッケージ・ソフト変遷 *配信含む

- 1972 アナログLP キング／ベルウッド OFL7
*キング・カッティング、RCAカッティングの2種類あり
- 1977 カセットテープ キング／ベルウッド A1014
- 1979 アナログLP キング／ベルウッド SKM7090
- 1981 アナログLP キング／ベルウッド K25A180
カセットテープ キング／ベルウッド K20H412
- 1989 CD キング／ベルウッド K25X371*初CD化
- 1992 CD キング／ベルウッド KICS2143
- 1995 CD ソニー／00 Yoo-Loo 00C01
- 1996 アナログLP ヴィヴィド／ベルウッド VSLP4012
- 1997 CD ソニー／00 SRCL4170
- 2000 CD キング／ベルウッド KICS8811
- 2001 アナログLP ウルトラ・ヴァイヴ／ソリッド BZJS5006
- 2012 CD キング／ベルウッド KICS2557
- 2015 アナログLP キング／ベルウッドKIJS90005
*180g重量盤、監修:和田博巳
- 2017 UHQCD キング／ベルウッド KICS2625
- 2017 アナログLP FUJI／ベルウッド FJLP1001
*45回転仕様2枚組、監修:湯浅学
- 2018 カセットテープ FUJI／ベルウッド FJCT101
- 2022 ハイレゾ音源3フォーマット キング／ベルウッド
*e-onkyo music、mora、ototoyなどで配信

に1年間かけて順次レコーディングが進み、初ソロ作『大滝詠一』が72年11月にリリースされた。実は大滝の頭の中にはシングル6枚を出せれば、その12曲をアルバムとして発売、という構想があり、それを反映し、当初は乗合馬車を意味する「Omnibus」と題する目論見だったので、今回の50周年盤『大滝詠一 乗合馬車 (Omnibus) 50th Anniversary Edition』はそちらを採択している(※以下、アルバム名は原名『大滝詠一』と記載)。で、乗合いなので本作には統一的なコンセプトはなく、はっぴいえん

どと併走して生まれたことにも因り大滝の音楽への愛情とこだわり、そしてパッションと遊び心がまます素直な形で反映されている。はっぴいえんどの4人でニューオリンズ・ファンクのダイナモだったミーターズばりのうねるセカンド・ラインを執拗に展開させる「びんぼう」での大滝の聴く者を捉えて離さないエモーションナルなシャウトは超二級品。アーチー・ベル「タイトウン・アップ」やオズモンズ「ワン・バッド・アップル」の妙味が縦横無尽に交錯する「五月雨」では蠢くりズム・セクションが官能を絶妙にくすぐる。これら

アップテンポ曲の白眉は細野晴臣(b)、鈴木茂(g)に林立夫(ds)、松任谷正隆(p)も加わった「あつさのせい」。いうまでもなく後のキャラメルママの構成でデラニー&ボニーばりの強靱なスワンプ・ロックを展開。中でも林のドラムがキレキレで、その圧倒的なドライヴ感に乗って大滝はあえて歌詞を単音ごとに区切るように唄う。メインフレーズではへあつ、つさ、の、せいとことさらにアクセントを強

調し、それを煽情的な女声コーラスとのコール&レスポンスでくどいほど繰り返す。なので僕にはどうしても「Just Don't Say」としか聴こえず、その見事な仕業には脱帽するしかない。

で、続く「朝寝坊」は一転してスウィングーなブルース基調のバラード。大滝ならではのヨードル唱法でノスタルジックでドリーミーな世界に変させる。そこからの2曲は作詞・松本隆、作曲・大滝の湿性を帯びたメロディアスなスロー曲。

大滝のポップスの引き出しを エンジニア吉野金次が 一部始終逃さず捉えている

仔細に言及するには誌面が尽きてきたが、そう、まさに「風街ろまん」と「ロング・バケーション」(81年)をつなぐ麗曲群だ。松本隆が書き上げた風街のイメージをロックとして具象化した「風街ろまん」はまるで墨絵かのような枯淡の風情が持ち味だった。いっぽう「ロング・バケーション」はポップスの黄金率を万華鏡のように散りばめ、専業作詞家となった松本隆の完成度の高い恋の情景を豪壮に描いた総天然色の音楽大絵巻だ。



Photo: Makoto Nozumi

And this "Eiichi Otaki" is located exactly in the middle of the two, and brings out Otaki's inexhaustible amount of pop music.

Mixing them with a talent that can be called skillful, each piece is created into a rich and exquisite song.

I am this a
 Rubum Nico
 Even more attractive
 What happens is
 that mix
 char is po
 inside the ps
 stay in
 not,
 Rather intense
 Good rock
 Soul Myu
 -Jick,
 Or perhaps
 it comes down
 to the dynamics
 of introspective
 singer-songwriter
 music. In other words,
 Eiichi Otaki's
 tastes may be limited
 to pop music,
 but as a creator he
 was naturally
 predisposed to express
 rock-soul grooves.

Special issue related to Eiichi Otaki published by Stereo Sound



Eiichi Otaki A LONG VACATION Reader
 40th ANNIVERSARY Supervision:
 Manabu Yuasa Y2,750 (tax included)



NIAGARA TRIANGLE Vol.2 Reader
 40th ANNIVERSARY
 Supervision: Manabu Yuasa Y2,750 (tax included)

That's how I feel (though I may not have been aware of it). Engineer Kinji Yoshino goes back to his roots in creating sounds that go back to his roots, capturing every detail of the chemical changes without missing a single drop of flavor. In addition, this 50th anniversary edition is packed with rare tracks unique to Otaki, allowing you to learn who Eiichi Otaki is and enjoy the brilliance of his origins and the excellence of his skill. It's a great product package.

Vertere



Koji Yamamoto

Visit to Valtele, UK



What is important in engineering

**Ask the right questions first,
and think carefully**

In late September, just after the funeral of Elizabeth, I landed at Heathrow Airport in England. The purpose was to visit Valtele, a company based in

London.

The company is headed by Toraj Moghadam. In 1985, he founded ROKSAN with friends and designed the Xerxes turntable and the Artem iz tonearm, which was the beginning of the analog playback era when the CD era was in full swing. He made his debut in the audio world with this device. At the same time, we are trying to change the image of traditional analog players.

With their vivid and subversive sound, they gathered many supporters in Japan, and the joint name between Roxane and Xy's grew significantly.

In 2006, Mr. Toraj left Roxan and founded a new company, TM Systems. After developing cables, the company name was changed to Vai Tele Limited in 2011, and the company began full-scale development of analog playback equipment such as turntables. I will do it.

There are two models of Player 1 currently being imported and sold in Japan: MG1PKG MK2 (PKG = package/tone arm included) and SG1PKG. Just before I flew to London, I had a chance to listen to the high-end model SG1 PKG at Kawahiro, but...



Valtele's listening room on the second floor. The monitor speakers are British PMC's MB2SE (3-way passive type), which are tri-amp driven by FM Acoustics' power amplifiers (FM111, FM108 MKII, FM108). FM Acoustics equipment was used as a reference for the preamplifier and phono equalizer, and the listening session was conducted with Valtele products incorporated into the system. The Valtele office building is a two-story building located in a corner of Oliver Business Park in London. The first floor is the assembly section and parts warehouse, and the second floor is the office and listening room.

和文

I was struck by the sharp sound of a still stream, as if I had been slapped on both cheeks (the cartridge was a Valtele Mystic MC, and the phono amplifier was a Kanoa PH1.10).

I was especially taken aback by the descriptive power of Bernard Purdy's drums, which can be heard on the second album "Secret Meeting" by the British rock band Hummingbird. His transcendental groove and sense of time were heard with an amazing transient feel. Sometimes I find myself saying, "Analog music does have a warm sound, after all," but SGIPKG's sound is the complete opposite. Its characteristic feature is the crisp half-day sound, which is extremely refreshing. For supple and emotional musical expression, my home's Lin Climax L

P12 is not defeated. However, when I heard Bernard Purdy's intense back beat, something I had never experienced before, I was reminded of the difference in the expressive power of Record Player 1. "Maybe I should have another one?" My mind was in a million strands (someone said, "Hey, where am I going to put it?").

Mr. Toraj Moghaddam

says this:

Valtele, located in London, had assembly facilities on the first floor and an office and listening room on the second floor. The monitor speakers are British PMC's MB2SE, and are equipped with an FM Acoustics amplifier for Bun-I-Back. The tiger that picked me up at Heathrow Airport



On the left and right of the stairs leading up to the second floor from the building, there are many works by Valtele Records on display, along with photographs of Valtele products. Currently, we are releasing works by a total of three artists, including the photo "Caesar." It is also planned to be available in Japan, and we expect to be able to provide details in the next issue.

Mr. Ji was born in 1958 (oops, he's the same age as me. Let's call him Toraji-kun). In Valtele's listening room, in a restaurant, in a jazz club, at Abbey Road Studios. I spent three days with him, and I found him to be a very kind man, with a dog-like voice and constant cries. The models he has designed so far



Mr. Touraj Moghaddam, who heads Valtere: After working at Roxane, which was highly popular with TMS/Xerxes/Radius, he founded his own company TM Systems in 2006 (changed its name to Vertere Ltd in 2011).) was originally a cable star.

However, it is now used for analog-related equipment such as turntables, phono cartridges, and tone arms in addition to arms and phono equalizers, we have a rich product line including racks and insulators. Building a nap. Also, as my love for music grew, I started the Raku label | Valtele Records. He even stands up. At Valtele, we continue to play a central role in product design and development. We are not only involved in the manufacturing process, but also in manufacturing the highest quality tonearm Reference Ton.

Mr. Moghaddam is the only person allowed to assemble "earn Generation III".

I was immersed in the process of making things.

It seems that.

--I heard that you graduated from Imperial

College London. What did you major in?

Tala TM Abar

majoring in mechanical engineering. I graduated from graduate school with 5 degrees.

For the past year, we have been working on the structural design of high-speed sword turbines for power generation.

was doing. --Is

that experience being put to good use in your current work?

Do you think so?

TM: I don't think it's directly related, but "Science is engineering." The important thing in science is to first ask the right questions, and then to think carefully. It's about thinking. Jump to solutions immediately

It is not.

— You founded Roxane in the mid-1980s and made your debut with the Xaxys turntable and the Artimize tonearm. At a time when CD playback was becoming mainstream, why did you decide to compete with record players?

TM: At the time of its release, the sound of the CD was incredibly childish. There was a lot of talk about it being the "perfect sound," but... On the other hand, I was convinced that analog players still had great potential. So I decided to take on the challenge of seeing what I could do with Hakubun. I believe that analog records will not disappear anytime soon. I was there.

When I looked at the code player, I had a suspicion that he was a bit nervous, but that was not the case at all, and the interview was much more fun than I expected, and I heard many interesting stories. --You were born in Iran, right?

Toraj Moghaddam (TM): That's right. I was born in Iran and went to a boarding school in England when I was 20 years old. I have been in this country ever since. Before the 1978 revolution, Iran was a very easy-going country and had a soft spot for Western culture. That's why I've been into rock and soul music since I was a teenager. Also, my father, who was a soldier, was good with his hands.

I love working and working. When I was 2 or 3 years old, I went to my father's workshop.



---I don't think the core of your record player design concept has changed at all since Xyx's. The importer's documentation states, "The axis of rotation must be clearly defined and the needle tip must vibrate only through the grooves. This is what the design is all about." Do you have anything to add?

TM No, there isn't. We have always strived to reach that H mark. As I mentioned earlier, the most important thing in engineering is to ask the right questions. In other words, searching for answers to the right questions is the guiding principle for design. Although there are many similarities between the players I have worked on since the Saxes, Valten's Ncord player has achieved much more than its initial design.



Ashley Dyer is Moghaddam's right-hand man and director of marketing and operations. Formerly a rugby player, he is a hobbyist who loves audio and music (as well as cars and whisky). He is also an expert in brewing coffee.

---For example, is it the multilayer structure of the acrylic chassis or the separation of the inner and outer top boards?

TM: That's right. Of course there are others.

--The separate structure of the inner and outer top boards can be thought of as an evolution of the slits used by Saxes. right.

TM Yes. All of the turntables I've worked on are designed so that the overall structure of the cabinet isolates both external and internal vibrations, but it's more important to deal with internal vibrations:

The use of ultra-fine spindles and spindle caps has also continued since Xixys. TM The top spindle diameter is made thinner.



Urmila Waghajani, Operations Manager. He says he has worked with Mr. Moghaddam since his days at Roksan.

The reason for using a removable cap is to avoid direct contact with the record, thereby preventing vibrations caused by the rotation of the spindle from being transmitted to the record. Since then, the diameter and length ratio of the lower main spindle has been maintained at a ratio of 1 to 1 day. Of course, this is a ratio obtained as a result of sound quality studies. By the way, the diameter of the main spindle of products from the Roksan era was just under 5mm, but Valten often uses a diameter of 7mm. Both This is to lower the vibration frequency. ---So why did Valtele choose cast acrylic for the chassis? Saxies were made of wood.

TM Acrylic resin tends to be acoustically attenuated. In other words, the sound is less quirky. Additionally, it is virtually unaffected by changes in temperature and humidity, so it can demonstrate stable performance all over the world.

There are advantages. Roxanne's turn This is the weak point of the table; the wooden chassis does not provide the required performance in areas with high humidity, such as Southeast Asia. The turntables you designed are all belt drive. other

What are the advantages compared to the method of is there.

The TM belt drive allows the motor to be moved away from the platter, allowing the stylus and groove interface to



A careful lecture on the bearing structure of turntables, including modifications from the Roksan era. Mr. Moghadam who gave it to me. What was impressive was that he said, "My way of thinking has not changed from before."
I am confident in my design, and I am confident that I am more confident in my design and that I am more confident in the accuracy of parts machining.
 "I have now achieved a graduation degree," he says, expressing how the current Valtele products are getting closer to his ideals. He seemed to be talking happily.



As part of the demonstration, they tapped the platter with their fingers and asked Mr. Yamamoto to hear the sound. Mr. Moghadam, the highest quality F with a two-piece platter (made of aluminum alloy).
 In the case of RG1, each piece produces a beautiful sound, but combining two pieces cancels out the sound. It is said that it is designed so that it does not make any noise. On the other hand, a one-piece platter is used. For SG1 and MG1, the sound can be suppressed by itself, and it can be combined with cast acrylic attached to the top surface. If you try to design it for optimal conditions depending on the situation, you will get stuck.

- Minimize the amount of interference to the face.
 I think this is the best method possible.
 There are design challenges associated with using a belt as an isolator, but I believe they can be addressed much more effectively than the comparable issues of dincted and idler drives.
 ---I see. By the way, the company name Valten
 What does that mean? TM
 means "turning point" or "change" in Latin. In 2006, I realized that there were some areas in the design of record players that needed to be reconsidered. I decided to leave Roxanne and embark on a new journey.

That's what I did.
 ---How many employees do you currently have?
TM: There are 15 people in total. Ten of them work in the administration and production departments. We also have two freelance design staff and two marketing staff.
 ---Now, please tell us about the new products that will be released in the future.
Development of TM DG1's latest model DG1S and phono amplifier Phono! MK2L has been completed and production will begin in September. I have several other ideas for new products, but I can't talk about them yet. It's not a floor.

Overview of Valtele's latest machine, DG1S
 Now, let's talk about the fact that it has not yet landed in our country.
 Let's take a look at the overview of DG1S. This record player is the latest version of MG1PKG's younger brother, with a cast acrylic charger mounted on a steel base. This chassis, like the top model, has an inner board and an outer board. It has a separate structure.
 The tone arm is a 5-layer polymer flat arm, and the arm cable is inside the polymer.

embedded in. I don't like the resonance of metal pipes.

Toraji-kun says that he adopted the Bolimar.

The power supply is a DC adapter type. By the way, M

G1PKG and SG1PKG are this adapter

connected

separate housing

-Tardora

This is a mechanism in which the turntable is driven

by the Eve unit. The DG1S is of course scheduled

to be released in Japan, and Takstock, the importer,

says they would like to sell it at Memagendai

(depending on exchange rate

movements). By the way, Valtele has SG1PKG.

RG1 is a product that is positioned as a high-end model. It is an

ultra-luxury model with a recommended

combination of

approximately 8.8 million yen for the

tone arm and approximately

5.8 million yen for the power

supply unit, totaling over 19

million yen, and is naturally

made to order.

After the interview, the

new phono amplifier

Connect with Phono! MK2L

First, I listened to the sound of the DG1S (the cartridge is Valtele's MM Saber MM).

The look is quite different from the higher-

end MG1PKG and SG1 PKG, but they share a common

tone, with a light sound with excellent transients. The

richness of expression in the midrange and the depth

of flavor make you realize the charm that is unique to

wooden machines. Compared to MG 1PKG, I get

the impression that it lags behind in bass extension and

high-level linearity, but considering that it is a player

system that costs less than 1 million yen, its performance

is extremely attractive, and DG1S is Gathering

enthusiastic attention from audiophiles in our country

It's inevitable.

we listen to the same music

I spent my youth

Valtele's listening room has many



Staff working in the assembly section on the first floor.

everyone. ... Rather than using the so-called line production method, one person handles various construction pillars. Valtele products were made in a style similar to the cell production formula that ... However, the only thing involved is the production of the tone arm of the Fino cartridge cartridge part. The staff who can do this have already been decided. During the interview, insulator ... The assembly work for "Iso Foot" was reaching its climax. ...



The number of people working as production managers has increased rapidly. It has been about two years since Mr. Moghadam asked me to respond to demand.

Previously joined by Nigel Charles

Before Termae, I was working on the feed of an automatic city company (for about 30 years)

), Valtele has a lean manufacturing system

(Systematized based on production methods in the Japanese automobile industry)

The same method was introduced, which introduced the idea of

How important it is to make products with the same quality, and

"Manufacturing professionals" who are familiar with the methods to achieve this

is



If you upgrade your system with Valtele's top-of-the-line machine | RG1 turntable (recommended tone arm "Reference To nearm Generation III" assembled by Mr. Mokhadam himself, and the top-of-the-line motor drive RG1 Reference Motor Drive), you can purchase it at E-Ki. The price is said to be around 19 million yen). As a general rule, models up to the MG1 are sold as a package, but for the quasi-flagship SG1 and higher grades, it is possible to select from multiple tone arms and motor drives.



Next year, the latest analog player | DG1S from Japan will be released, DG stands for Dynamic Groove, and the long-awaited new plate-shaped tone arm with a 5-layer structure (Groove Runner S Tone arm), this is a belt-drive machine that is the youngest Valtele model. The tone arm, which has a unique taste receiving structure as shown in the photo above, is also manufactured in-house by Valtele.



"MG1 PKG MK2": the latest specification of Valtele's Japanese debut machine, has just begun to be introduced in the fall of 2022, and the tone arm and motor drive installed have been updated. It is said that the "MG1 mk2" turntable itself has no history.

The SG1 PKG turntable, which will be introduced in Japan this spring, is essentially a flagship machine that combines the "SG1" turntable with the "Super Groove PTA HB" tone arm and the "Tempo" motor drive. The rack is equipped with an advanced motor drive, the Imperium Precision Motor Drive.



Many records are stored in the rack. What really caught my attention was the array of rock and soul masterpieces from the 1960s and 1970s. There were many records that I was familiar with, and I had a deep feeling that in those days, in Iran, England, and Japan, we all spent our youth listening to the same music. Toraji-kun is smiling proudly there. I brought some records with blank jackets. These were a number of valuable acetate discs that he had inherited from his friend, Miles Showell (see separate interview article); who is famous as a master of half-speed cutting. By the way, Mr. Showell is using SG1PKG at home.



Mr. Koji Kawa was very happy when he received the precious acetate (lacquer) that was half-speed cut by Mr. Moghaddam. 211 and listened to many records, but the highlight was these non-acetate records.

It is said that you are using
Select from among them.

- Mr. Wells

The Beatles'

"A Day in

the Life" (from

the 50th

anniversary

commemorative remix

album) and

Marvin Gaye's

"What's Going On"

are available



on SG1PKG. I listened to it, and the sound was absolutely amazing, and it's one of the best sounds of my life.

It was a great

experience. "A Day in the Life" is a contrast

between the tight band sound produced

in Studio 2 at Abbey Road Studios, where

The Beatles were based, and the orchestral

sound recorded in the spacious studio. It

was spectacular, and the thrill of the orchestra

as it crescendoed toward the ending made

my heart beat faster. Speaking of how amazing

the chords are at the end, played on multiple

pianos... I suddenly fell off the chair.

Of all the records Hakubun has cut, Mr.

Showell says this is the one he is most attached to.

SG1PKG's performance of "What's Going On" was also amazing, and without a doubt, it's the best rendition of this song that Hakubun has ever heard. The bass sounds were so realistic that it was as if James Jamerson, who plays original phrases, had come to life and was playing the bass in front of the sun, and it had a shock that made my body stiffen. Shunnen, I think audio is always amazing.

"The most important thing in academia is to first ask the right questions and then think carefully about them." The depth and certainty of Toraji Moghaddam's design philosophy, the wonderful sound of the record player he created, and his deep appreciation for music. Touched by love and feeling elated, I hurried to my next interview destination. It was.

Miles Showell

Special edition of Valteale's visit to England

Abbey Road Studio
Mastering & Cutting Engineer

Mr. Miles Showell

interview

Listener Editorial Department

What's important is to imagine

Miles Showell

Abbey Road Studios
Freelance Mastering & Cutting Engineer

Born in 1966 in Kent, south-east of London, England. He started his career at Utopia Studios (London) in 1984, and after working at famous studios such as Copymasters, Masterpiece, and Metropolis Mastering, he began mastering and cutting at Abbey Road Studios in February 2013. Currently, he is known worldwide as a leading expert in half-speed cutting (mastering), and to name a few of the artists he has been involved with so far, he has worked with artists such as The Beatles and The Rolling Stones, Queen, Eric Clapton, The Who, Paul McCartney, The Police, Ed Sheeran, Furlichi, ABBA...the list goes on and on. Even in my private life, I love music and audio, and my analog system at home includes a Valteale SG1 turntable and a Mystic MC phono cartridge. My favorite speakers are a PMC Tallboy 2-way machine called "They are wonderful!" "Twenty 5.23"

remixed.
tape was retroactively
The 4-track session
album "Sgt."
2017. The Petes'
Hearts Club in
by Pepper's Lonely
was released
This historic project
turntable "MG1" and Valteale's analog
During production, the acetate
quality of discs and test press discs.
There are photos to check the



Because MG1 was used. Deeply connected to this is the main character of this article, engineer Miles Showell, who was in charge of cutting the remix version of the "Sgt. Pepper's" LP record. In the extra part of the visit to Valtele, half-We bring you an interview with Miles Showell, who is known worldwide as the driving force behind making speed cutting (mastering) popular in the modern era. On the last Sunday of September, our reporting team visited Mr. Showell's cutting room at Abbey Road Studios in England, guided by Mr. Toraj Moghaddam, head of Valtele. Not long after the announcement of the release of The Beatles' remix version of "Revolver" went around the world.

Mr. Showell welcomed me with a big smile and said, "Welcome to Abbey Road Studios." After carefully showing me around the three recording rooms, he invited me into the white cutting room. The first thing we asked was how he came to know about Valtele. "I was introduced to him by Crispin Murray, a colleague of mine at Metropolis Mastering, where I used to work. When I visited Valtele's office with Crispin, I still remember the sound that left an impression on me. Hmm. Unbelievable Blue. It was unbelievably wonderful. I think it was about seven or eight years ago." I turned my attention to Mr. Moghaddam, and Mr. Moghaddam continued the conversation and said, He supplemented me.

was applied first. The next step was to play an analog record cut from the same sound source using a Valtele player, but the re-created sound of the digital sound source that I heard first was so wonderful that the Valtele player was able to reproduce that sound. I started to worry, wondering if I could keep up. However, when Crispin tried playing the analog record, he became very excited and the venue erupted in cheers. Crispin couldn't contain his excitement and said, "I really have to meet the man who cut this record," so he brought Miles to my office the next day." Showell said: "Crispin is crazy. But my ears are very reliable," he says with a laugh. The relationship between Mr. Showell, Mr. Moghaddam, and Abil Road Studio quickly became close, as their pursuit of sound was very similar. Valtele equipment was often used at launch events for The Beatles' LP records (such as "Beatles Zoo" and "Mono Box") held at Abbey Road Studios, and Mr. Showell used Valtele Records' cutting. (Coincidentally, Universal Music's representative for The Beatles, Guy Hayden, was a Xyz user)- Furthermore, there is Mr. Showell's cutting room and Mr. Showell's mountain home. Valtele products are installed in the audio system of



"A few weeks before that, Old Do A hi-fi show was held in Nonzer, and an attempt was made to assemble the same set as Metropolis Mastering. A system centered around PMC monitor speakers was set up, and we were invited by PMC President Peter Thomas to participate. At the venue, Crispin, who I mentioned earlier, was in charge of the setup, and the digital sound was mastered at half speed. Source (Eleanor McEvoy album)



Mr. Showell's mastering room in Abbey Road Studios is set up with equipment selected by "Kanshin Ear", and the monitor speakers are PMC's, which he trusts today. We use the active type "MB2 XBD" (a 3-way configuration device equipped with two 31cm diameter woofers).

It's being put in.

"I am Abbey Road

I'm working in the studio

However, the contract is in the form of a freelance contract. This is because I want to use the equipment I choose with my own ears, without being bound by studio rules.

I use PMCs as monitor speakers because I like their sound, and I own Neumann Cutting Race VMS80s. The interior is not genuine, but has been extensively modified to improve the sound quality, and we are confident that it is in top-class condition among the VMS 80s in operation around the world. A Valten cable connects the cutter head, which plays an important role during cutting, and the cutting amplifier. Valtele's cables are also available elsewhere.

I use it a lot, stop

The wiring method and detailed I also neglect the setting.



Although we have known each other for less than 10 years, Mr. Toraj Moghaddam seems like a friend of Japan (photo) (left) and Miles Sewell, their friendship seems to have had a deep influence on each other's manufacturing. It can be seen. This is probably the central encounter between the creation of software and the creation of hardware.

not. This is because the final sound changes greatly by accumulating improvements in small details. You know a lot about that, right?"

I deeply agreed and told Mr. Moghaddam who was sitting next to me that he was just like us audiophiles, and he told me a few stories about how Mr. Showell had an amazing ear, and at the same time he spent a lot of time with me. He spoke passionately about his approach to sound, as he generously approaches mastering and cutting. One of those things is half-speed cutting.

cormorant. It takes a lot of work, and it takes more than twice as much time as usual," Moghaddam said, and the topic turned to half-speed cutting.

Advantages and disadvantages of half speed cutting

What is half speed cutting? Analog



When producing lacquer discs, which are essential for producing green records, the sound source is played back at half speed and cut at half speed accordingly. This method is also widely known for the works released by the high-quality sound label Loumobile Fidelity Sound Lab around 1980. Although this method has many advantages in terms of sound quality, such as reducing the burden on the cutting system, it is not a popular method as it is fraught with various difficulties in implementation. However, in recent years, Mr. Showell's "Half Speed Mastering LP" from Abbey Road Studios has been appearing one after another. As Koji Yamamoto notes in the main story, the recording team was listening to "A Day in the Life" from "Sgt. Pepper's" in Valten's listening room.

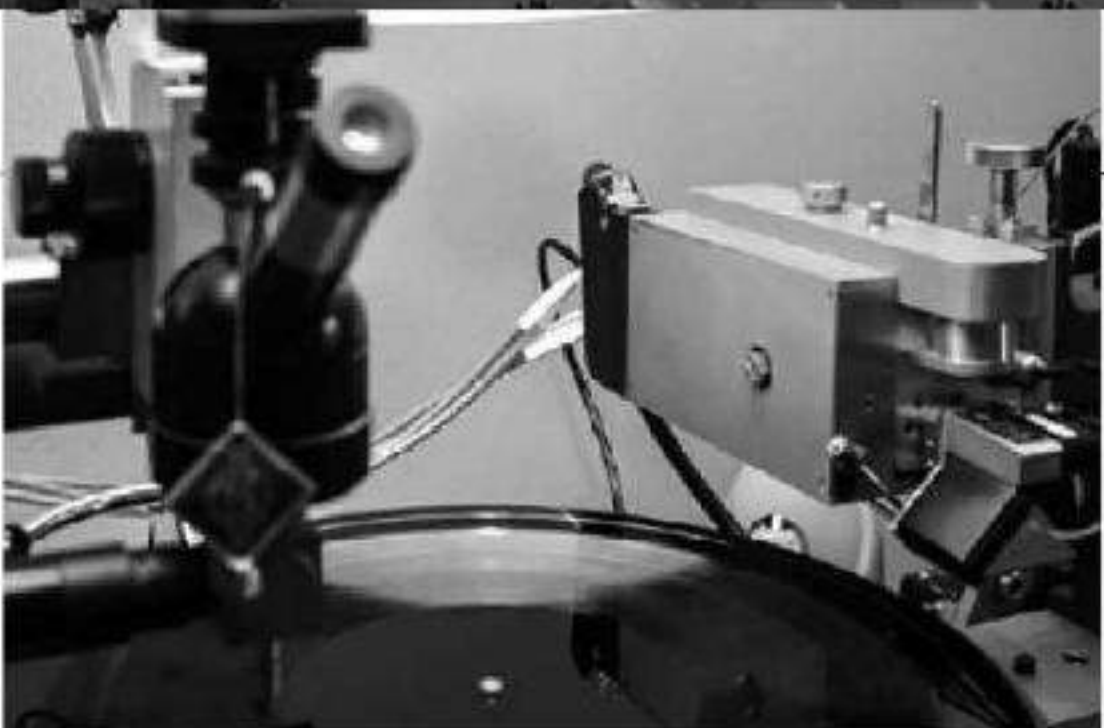

Mr. Showell's personal property is a Neumann cutting machine (a combination of VMS 80 Cutting Lace and SX74 cutter head, which was originally a cutting is for DMM (Direct Metal Mastering). "At first, they said it would system that took 18 months to modify for lacquer cutting. Guamp was SAL74B). take nine months," he says with a laugh, but it seems that it took twice as long for him to reach a satisfactory level of improvement. By the way, the people who worked with me were engineers Crispin Murray and John Goldstraw, both formerly of Metropolis Mastering and currently working as freelancers, and they say they have a vast amount of knowledge and know-how about cutting systems. Regardless of the door or control system, the internals have been extensively customized, including a built-in RIAA filter (EQ curve) that supports both half-speed and real-time, as well as all capacitors and controls in the signal path. A lot of work was done, including replacing the transistors in the amplifier circuit and designing a new power supply section. Customization and research have continued, and even now, the wiring between the cutter head and cutting amplifier has been changed to custom-made products from Valtele's highest quality Pulse-HB (Hand Build) series. We are passionate about pursuing sound quality.

They were listening to the acetate record (a lacquer record that Mr. Showell had half-speed cut), and everyone was knocked out. The interpreter relays the details to Mr. Showell.

"The advantage of half-speed cutting is that it has excellent transient and high-frequency response. This advantage is especially easy to make use of in works that feature 3D-like spatial depictions. In the Life" might be the perfect showcase."

When I asked him the obvious question, why hasn't half-speed cutting become more common, he doesn't look offended. He answers:

"First, there is the issue of equipment. The big one is the difference in EQ curves. Most modern LP records use the RIAA curve, but half-speed cutting cuts the sound source at half the speed. You need to use a different EQ curve (the finished product uses RIAA curves). There is no absolute correct answer here, and experience and know-how are important, but in my case, I use Mobile Fidelity Sound. Stan Ricker, a great engineer known at the lab, was a great help. Unfortunately, he passed away in 2015, but I am still grateful to him.

Another problem with equipment is that the half

The cutting machine is rotated in precise synchronization with the sound source that is played at a speed of Regarding this, I have been thoroughly coordinating my system with Crispin and other trusted engineers. By the way, it took me one month to restore the VMS80 after I got it.

Others require time and effort. There's a lot of work to do, example

For example, there is the issue of de-essing. When cutting a record, it is necessary to adjust and process the consonants emitted in vocals such as "S" so that they are not distorted. It contains a lot of sound, and it tends to be more pronounced when recorded with a microphone. Also, English has stronger sounds than Japanese, so more precise responses are required in English-speaking countries). In real-time cutting, it is possible to make dynamic adjustments using a special device called a de-esser or a limiter, but half-speed You cannot use such equipment as is for cutting. Additionally, machines can't distinguish between sudden attack sounds such as hi-hats, snares, guitars, etc., and vocal prophecies, so they may end up modifying adjustments.



vinegar. Therefore, before cutting, I listen with my open ears and make adjustments one by one to only the necessary areas. Although it is a very time-consuming process that requires patience, it is possible to restore the sound that was lost during the cutting process. You can't do that.

half speed

An additional difficulty with cutting is that you have to listen to the music at half speed while cutting. Actually, last week I had H who worked for a whole day. I entered the studio at 9:30am, and by the time I got to the river it was 9:30am the next morning. Just think about listening to music played at half speed for that amount of time. I felt like I was going crazy (lol). However, the finished sound blows away all that hard work." We asked him about the policies he keeps in mind when cutting. The immediate response was to imagine." When I tried to chime in and said, "That sounds like a mountain of John Lennon," he said with a serious face, "I always think from the listener's point of view and what they want to hear from the music. How do you feel and where do you listen to the music?"



I use an Ampex to play analog tapes. "ATR102 | Open reel deck:"

I imagine what it would be like to listen to it. It's also important to respect the master's sound and, if it's in really good condition, try not to change it as much as possible. Also, from my standpoint, Hakubun's favorite music has always been This does not mean that you can take on the responsibility. Sometimes I'm asked to work on a piece by an artist I've never heard of. When that happens, I think that there is someone somewhere in the world who loves this work the most, and I imagine what I can do to make it so that that person can enjoy it. I'm really glad I didn't have to choose the works I was responsible for. If I had chosen works based on my own tastes, I would not have been able to find the works that I wanted. Because there's a lot of fun to be had."

full of music
childhood growing up at home

the first LP I ever owned. By the way, the "Sgt. Pepper's Lonely Hearts Club Band" was a code. Until then, I only had singles." was future and recovered. I was about 6 years old. It it to be a reward for me when I got sick in the and I begged my parents to do it. I didn't expect had no idea that I would be involved in this project, amazing experience that gave me goosebumps. "I father owned a music store. It was an an early age, playing jazz and rock. Showell's Showell always had music in the house and car from kinds of music, including blues and classical music. He grew up in an environment filled with all

It seems that there was a lot of trouble, but his father was especially fond of it.

Jazz was the key. Miles Day in the mountains



Worldwide on October 28th this year The Beatles' "Revolver" Special Edition (originally released in 1966) was released. It was a stereo remix from the 4-track master using the latest digital technology called Demix. The LP record was half-speed cut by Mr. Showell. On the left in the photo is the remixed version of "Sgt. Pepper's Lonely Hearts Club Band" released in 2017, which was also half-speed cut by Showell. The Beatles (also 50th anniversary edition, original released in 1967),

from that." In honor of Vis and Quincy Jones Quincy Jones, and Mr. Showell's name is derived Quincy, I would have said, "I like the music of my unusual name, but if I had been named would have been bullied at school because of It might have been. I'm glad I chose Miles (lol). I He continued, joking lightly. English) "My parents loved music, so I was the first to people." One of my favorite songs was "Gekko" (editor's note: of R was difficult for children, even for Japanese six months old, I learned from my father that the pronunciation given a player as a gift. At that time). What's more, when I was around with equipment and was I guess it was. However, I like playing



on them, as shown in the photo on the left, which shows how popular they are. All of these are masterpieces that have left their mark on the history of popular music, but Mr. Showell singled out "What's Goin' On/Marvin Gaye" (released in 1971) as one of the works that had a negative impact. There are many titles that are difficult to obtain these days, including 2017, so if you see a title that interests you, we recommend that you hurry up and buy it.

is that I couldn't adjust the rotation speed properly. sounds that were half-sounding and slow, and what I remember 16 rotations. Ever since I was little, I've been listening to It was the speed (lol). "Something like Thanks to Mr. Showell's personality, I was able to interview him. from beginning to end, creating a warm atmosphere. is no end to the stories, and the show is filled with laughter we held a Mozart concert at Wigmore Hall. There this interview, shared a meal, and after the interview, at half speed. We listened to a string quartet perform "That Wonderful Rubber," was released, Mr. Showell was walking through the cold streets of London cut remix version of the LP and chord of issue of this magazine, which featured the hand- they put into sound. By the time the winter to the sound, Mr. Showell and Mr. Moghadam must have the passion and outstanding technique Keeping in mind the contribution of quantity I would appreciate it if you could do so.



Audio Pilgrimage [Reprint Edition]

Kosuke Gomi

The long-awaited reprint version is finally here for the first time (about 30 years). "Music, for me, is a companion act that is tied to some kind of ethical sense. I am very aware of his own naughty parts. This is purified through music. Days of agony, words of desire, that's why I sat in front of the speakers, hung my head, and listened to Bach and Beethoven with tears streaming down my face." (Excerpt from the main text)

ISBN: 978-4-88073-197-1 List price:
2,934 yen (tax included)



audio wandering

Chiaki Iwasaki Works Collection

With Chiaki Iwasaki "Speaking of the person who made JBL's masterpiece unit 'L180' famous known as. On the other hand, in 1970, he opened "Jazz Audis" in Nakano, Tokyo, where he witnessed the best jazz music. Many legends have been born from this place as well. In this book, Mr. Iwasaki says, "This is a compilation of articles written in a total of 12 magazines such as Stereo Sound, "Jazzland" Swing Audio, and other Odina magazines and jazz magazines."

ISBN: 978-4-88073-307-4
Regular price: 2,096 yen (tax included)

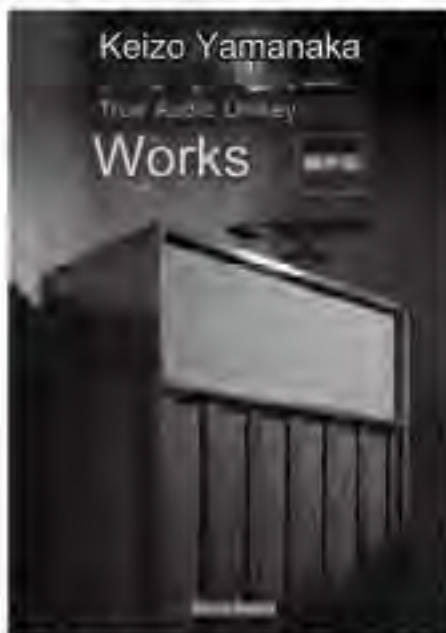

Keizo Yamanaka

Collection: True Audio Connoisseur

"He is a true ED course who has been responsible for writing StereoRound magazine since its first issue. His reviews of foreign ED products are especially well-received, and he has been active as an authority for many years. Many of the articles in this magazine are excerpts, revisions, and reorganizations of articles from back issues of magazines published by our company."

ISBN: 978-4-88073-341-8
List price: 2,098 yen (tax included)



Takuya Inoue collection of works

Takuya Inoue is famous for having a deep ear, but he is also a "master at using things". After listening to the sound for a while, I change the placement slightly. If I do that, the sound will be different from what it used to be, so I don't like it. Truly the world of Tomagic. The book is very easy to use and provides detailed hints on where to change things to improve the sound.

ISBN: 978-4-88073-355-5
List price: 2,098 yen (tax included)



What is good sound and what is a good-speaker? Fuyuki

Segawa's collection of works

The first issue of "Stereo Sound" was published by Mr. Tsugukawa, who has painstakingly written about the sound quality, design, operability, etc. of audio equipment to accurately convey to readers, and with great creativity. This is a collection of valuable works published from the issue to the final separate volume "81 Complete Test of the World's Latest Separate Amplifiers".

Magazine code: 67969-17 Regular
price: 2,096 yen (tax included)



Asanuma thoughts

[On-demand books]

Work of Fumihiko Asanuma 1983-2002

To commemorate the 10th anniversary of his death, a 600-page book was produced across editorial departments: Seasonal Listener Sound, Hi-FiV, Quarterly Small Theater. 1. From among the numerous articles that were published separately, The editor-in-chief of has carefully selected, lead, and audio as a hobby, and a passion for audiovisuals and high quality and high image quality. I want you to feel once again the high aspirations of

ISBN: 4-88073-286-2
Regular price: 15,715 yen (tax included)



Listening Mirror 1994-2006

Shoji Sugawara

Also includes conversations with Sadao Watanabe, Tomo Muramatsu, and Akira Sakata. The trajectory of a traditional jazz cafe owner who devoted his life to audio.

Hobbies are limited to troublesome things.
The white sword keeps the fun going.
This is because comfort only makes you ache. (Excerpt from the main text)

ISBN: 978-4-88073-143-8 List price:
2,934 yen (tax included)



Listening Mirror II Shoji Sugawara

Sound is thought.
A man fascinated by jazz and audio
Jazz Cafe Basi Owner Toshiji Kanbara's history from 2006 to 2014
A long interview in 1982 that explores the origins of his writings.
Also includes "Baishi 12"

Audio is a "listening mirror" that reflects your own Uchiyama.
(Excerpt from main text)

ISBN: 978-4-88073-329-6 (excerpt)
List price: 2,970 yen (tax included)



A photo of Shimago The BEST Sounding CD

"The Best Sounding CD" by Mamoru Shima, a serialized article in the audio magazine "Zenkan Stereo Sound" by Mr. Mori Baneshi, who is pursuing discs with good sound. This is a compilation of 10 years (2003-2012).

ISBN: 978-4-88073-316-6
Regular price: 2,619 yen (tax included)



The pleasure of nearfield listening

Hiromi Toshikawa

A popular project that has been published in the quarterly StereoSonic Limbe for 10 years has been published as a long-awaited book with the addition of Kazuyuki, the legendary rock bassist "Hachiroku". A collection of humorous reviews and essays about the enjoyment of music and audio that the author loves, who was the bassist for "Pal" and later worked as a music producer.

Nearfield listening is the best listening style that allows you to become one with the music (from the afterword)

ISBN: 978-4-88073-294-7 List price:
2,619 yen (tax included)

Stereo Sound Co., Ltd. Sales Department • To purchase, please visit a bookstore or

5-12-11 Kamiyoga, Setagaya-ku, Tokyo 158-0098

Mail order only dial: 03-5716-3239

<https://www.stereosound-store.jp>

visit our website.

stereo sawand store

search



@ss_sales



www.facebook.com/stereosound.put.ishing



Special winter sale, display & stock items, big sale!

TANNOY
Turnberry GR
 Listen to a variety of music on Turnberry, from symphony to jazz to rock. This is the Turnberry GR that impresses me with the way familiar songs speak to me in a fresh way.
 Regular price ¥1,200,000 (tax included) Special price for stock items
 Please contact us as soon as possible

B&W **805D4** [On display]
 You can display and listen to the latest D4 series' much-talked-about new product 8054. There have been major changes since the previous model 805D3. It looks forward to the D4 series.
 List price ¥1,122,000 (tax included) Special price please contact us

T.A.D.
Evolution 2-WN
 Adopting a newly developed award-winning cone, it offers rich, clear directivity and powerful bass reproduction.
[On display]
 List price ¥1,738,000 (tax included) Special price please contact us

TANNOY
Prestige GR Super Tweeter
 Equipped with a magnesium alloy diaphragm, your favorite speaker Big upgrade.
 List price ¥704,000 (tax included)
 Please contact us for special price on new items in stock.

VIVID AUDIO
KAYA-512 [On display]
 VIVID AUDIO's newly released KAYA series is compact, but inherits the lineage of higher-end models, and you'll be captivated by its design and the splendor of the sound it produces.
 Regular price ¥524,000 (tax included) Special price: Please contact us.
 Separately sold stand Regular price ¥170,000 (tax included)

JBL
SA750
 JBL has released the much talked about new product SA-750. A modern version of the classic SA-660. It also supports MC and MM inputs as well as MQA high-resolution CDs, and the 130W x 2 output has sufficient drive ability. Stock item special price
 Regular price ¥855,000 (tax included) ¥305,000 (tax included)

Air Force III Premium
 Equipped with a **By arm** Designed to support with 5.6kg
 aluminum platter, this model exhibits the principle of analog sound with the ultimate sound quality, pursuing deeper sound quality. You can preview it at any time.
 List price ¥1,080,000 (tax included) Special price for exhibition items

CHORD DAVE Converter
 The converter is amazing because it allows for such vivid musical expressions. High resolution with USB input is especially noteworthy.
 List price ¥1,650,000 (tax included)
 Exhibition disposal ¥1,058,000 (tax included) Please contact us for details

ESOTERIC N-05XD Now on display and available now
 Network preamplifier released by ESOTERIC became. It's very convenient. Equipped with a variety of digital and analog inputs, including USB. It is easy to use and the sound is excellent, and the headphones sound great.
 List price ¥935,000 (tax included) Special price please contact us

Display items, inventory items, winter sale
 ~ Final disposal sale held ~
 Period/December 1st to January 31st, 2020
 Great deal on in-store display items, warehouse stock items, used items, and special prices!

Analog player from ESOTERIC
Grandioso T-1 new release!
 The world's first linear motor-driven machine developed using the latest technology. player. Listen to the revolutionary Grandioso T-1's sound, which reproduces only the music information recorded in silence.
 *It operates at 10M clock.
 Grandioso T-1
 Exhibition commemorative price
 List price ¥7,700,000 (tax included) Please contact us

This month's special selections Bargain display items

B&W 801D4
 B&W's latest speaker, the 801D4, is a major evolution from the 800D3. Please check out the wonderful musical expression.
 Regular price ¥4,070,000 (tax included)
 Special price
 Please contact us

AUDIA FLIGHT STRUMENTO No4MK2
 Inspiring sounds from Italy I will tell you. Only the enthusiasts who listen to it can experience the greatness of this amp.
 Regular price ¥4,070,000 (tax included)
 Special price
 Please contact us

Marantz #7
 Marantz #7 Beautiful item has arrived. This is a refurbished product. There are no noticeable scratches and the body is in a new wood case, and it looks great, giving off the elegance of a masterpiece.
 This is a mid-term product.
 Special price ¥780,000 (tax included)

EMT930 /155ST
 An analog player representing EMT. shock up.
 Comes with scope (TSD-10 included)
 Refurbished special price ¥1,280,000 (tax included)

DEVIALET EXPERT 140PRO
 World's leading manufacturer with sophisticated design and over 100 patents. This is the most advanced audio integrated amplifier. 1000 of the world. Equipped with SAM function to optimally sound the above speakers. Please enjoy the splendor of Talamp.
 EXPERT 140 Pro ¥858,000 (tax included)
 EXPERT 220 Pro ¥1,375,000 (tax included)

This month's bargain items (display items), second-hand item, great sale! *All prices include tax.

"speaker" (pair price)

[JBL]
 ●4311A JBL's popular small alnico type speaker ¥150,000
 ●4338 Excellent condition ¥550,000

[ALTEC]
 ●2 1003B 300HZ 10 cell horns Special price ¥238,000
 ●515B Altech's two popular units ¥158,000 ●2888 ¥420,000
 Charged to precision type. Eye sound. 2 units with 15V power supply

[TANNOY]
 ●1LZ latest arrival late model in good condition ¥348,000
 ●Sterling/GR
 The latest Sterling GR is now in stock... ¥808,000

[QUAD]
 ●Speakers representing ESL Guide are now in stock. ¥178,000
 ●Q-32 This is a new, very rare vintage tube amplifier. ¥348,000

[B&W]
 ●801D4 801D4 piano black with a short shelf life **展示特価** ¥268,000

●804D4 Latest arrival 804D4 In stock Special price ¥1,600,000
 ●805D4 Walnut finish, latest arrival, in stock inquiry

Amplifier

[McIntosh]
 ●MI-200 Ultimate power amplifier ¥2,500,000
 ●MC-240 Latest arrival, early model with bonnet ¥358,000
 ●MC-7300 300Wx2 high power amplifier ¥238,000
 ●C-29 The perfect C-29 for JAZZ has arrived... ¥248,000 ●MX-110 Vacuum tube preamplifier in good condition, latest arrival ¥358,000
 ●MC-2105 Macken's classic classic with a different sound quality ¥248,000

[Marantz]
 ●SACD 30m Latest released SACD player Wonderful and absolute sound #7 Label ¥720,000 ●10m Initial product Comes with mid item #7 wood case ¥268,000
 Bard changed to Japanese specifications. There are some translations.

●Replica #7 This is a replica of the masterpiece #7 of yesterday. ¥300,000

[ACUPHASE]
 ●C-2810 Accuphase popular preamplifier Good condition ¥598,000
 ●U-BROS 6605 6L6P-P popular tube amplifier ¥360,000

[JBL]
 ●SA-750 Latest released integrated amplifier

[ESOTERIC]
 ●D-07X 32-bit dual mono converter popular for its old-world charm... (Exhibited product with list price ¥324,000) ¥218,000 K-03XD Popular player with a reputation New stock limited edition
 ●C-03Xs Current model high-end preamplifier ¥528,000

●7N-PC7500 Stress Nollipally Cable **特別価格**
 ●7N-PC5500 Stress-free power cable (List price ¥162,000) ¥88,000

(DENON)
 ●DCD-SX11 DENON's popular SACD player Luxury item ¥298,000
 ●PMA-SX1 Limited The miracle of integrated amplifier (In stock) Special price ¥688,000

[LUXMAN]
 ●C-9 LUXMAN popular preamplifier ¥308,000
 ●CL-38Uc latest vacuum tube preamplifier (now in stock) Contact us
 ●MQ-88Uc Latest power amplifier KT88PP New stock Special price ¥1,380,000

[EMT]
 ●930st 155ST/With shock absorber ¥1,180,000

[ORTFON]
 ●RMA-2121 Short type arm (A type) New Special price ¥110,000
 ●RMA-3091 Long type in stock New Special price ¥130,000

etc.
 ●VPI HW-16,5 Easy-to-use popular record cleaner (USDE) ¥48,000

Audio & visual specialty store
 AV Square
Kusakabe
 Utopia Tokyo District Agent
 6-24-8 Owada-cho, Hachioji-shi, Tokyo
 Transfer destination/Mitsubishi UFJ Bank Hachioji Chuo
 Branch Current account No.9008936 Kusakabe Electric Co., Ltd.

Founded 51
 years ago 042-642-5190
 FAX 042-642-5760
 Business hours/10:00-19:00 Closed/Every Tuesday and Wednesday
 "Home page <http://www.kusakabe.co.jp>
 Please be sure to make a reservation if you want to listen to the preview.

Map showing location near Hachioji Station and Owada-cho. Includes directions from Hachioji Station and Owada-cho.





































One of the world's leading audio specialty stores in the Tokai area.



Specially selected USED

(All prices include tax)

cross audio

 <p>TANNOY Autograph Monitor Gold 15 Shinkosha BOX (pair) ¥1,180,000</p>	 <p>TANNOY Autograph Monitor Gold 15 Shinkosha BOX (Pair) ¥998,000</p>	 <p>TANNOY Autograph HDP385A TEACH (pair) ¥698,000</p>	 <p>TANNOY RHR/N (pair) ¥598,000</p>	 <p>Accuphase A-200 (pair) ¥1,650,000</p>	 <p>JEFF ROWLAND MODEL 10 ¥348,000</p>
 <p>JBL 4367 (pair) ¥828,000</p>	 <p>JBL 4333A (pair) ¥298,000</p>	 <p>JBL 4330 (pair) ¥248,000</p>	 <p>TANNOY ILZ Monitor Gold 10 (pair) ¥278,000</p>	 <p>Mark Levinson No.23.5L ¥468,000</p>	 <p>Mark Levinson No.23L ¥298,000</p>
 <p>JBL 250T1 (hair) ¥248,000</p>	 <p>JBL S3100 (pair) ¥198,000</p>	 <p>JBL S143MKI (pair) ¥228,000</p>	 <p>JBL 4343WX (pair) ¥398,000</p>	 <p>Mark Levinson ML-3 ¥298,000</p>	 <p>UNISON RESEARCH Sinfonia ¥298,000</p>
 <p>Electro-Voice georgian (bear) ¥698,000</p>	 <p>West Lake BB5M-10VNF (pair) ¥498,000</p>	 <p>ALTEC 6041 (pair) ¥398,000</p>	 <p>ALTEC Crescendo 604E (pair) ¥298,000</p>	 <p>QUAD II forty (pair) ¥298,000</p>	 <p>Sonus faber Musica ¥198,000</p>
 <p>DIATONE AS-30015 (pair) ¥198,000</p>	 <p>Bell Wood Lansing S250W (pair) ¥298,000</p>	 <p>B&W 800D3 (exhibition) (pair) ¥2,980,000</p>	 <p>avantgarde DUONG2 (pair) ¥1,780,000</p>	 <p>McIntosh MA6900 ¥398,000</p>	 <p>JBL SA600 ¥298,000</p>
				 <p>marantz #7 ¥598,000</p>	 <p>AUDION Silver Night 300B P.P (pair) ¥248,000</p>
				 <p>PS AUDIO perfect Wave Transport&DS DAC (pair) ¥398,000</p>	 <p>SOUL NOTE CT1.0 Transport ¥198,000</p>
				 <p>Clear audio concept MM ¥128,000</p>	 <p>MICRO BL-99V FR-64fx included Without vacuum ¥148,000</p>

HI-SOUND HI-VISUAL
KIOSS Cross Audio
 Handling audiovisual products from around the world
 3027 Nishikaizuka, Iwata City, Shizuoka Prefecture 438-0026
 TEL 0538-32-1023 FAX 0538-35-5348
 Homepage <http://www.kloss.co.jp> AM10:00~PM7:00 Closed on Wednesdays

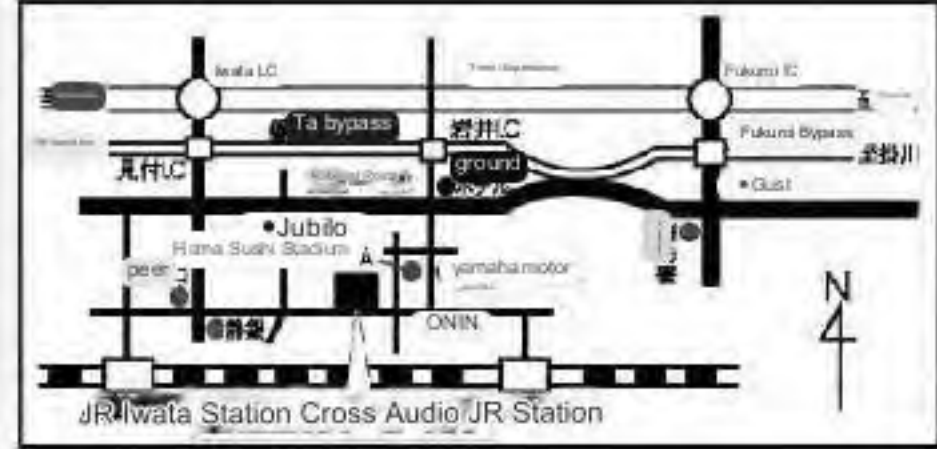

※Payee
 Shizuoka Bank
 Iwata Branch
 (Temporary)308407
 Cross Co., Ltd.
 *Long-term division
 I accept
 1 to 84 times

AUDIO HOME THEATER FAIR 2022

Audio & Home Theater

Large exhibition and sale

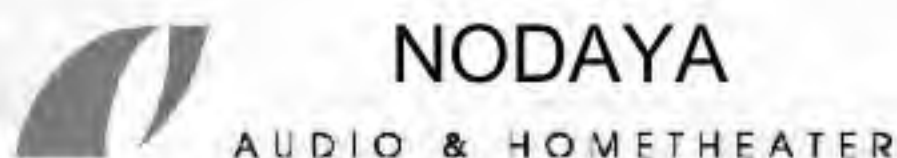

Providing you with exciting products.



Audio & Home Theater Nodaya Large Exhibition and Sale

● Utsunomiya | Marronnier Plaza

Sendai store, Koriyama main store, Fukushima store
 開催の開催を予定しております。
 Please check the website for details.
 詳細はホームページをご覧ください。

Scheduled to be held on  December 17th and 18th!

Please check the homepage for details!

Due to the spread of the new coronavirus infection, there is a possibility that the event will be changed to an in-store event.



Nodaya Sendai store
 1-3-10 Yaotome, Izumi-ku, Sendai, Miyagi Prefecture
 Tel. 022-725-5193
 Fax. 022-725-5191
 Mail. sendai@audio-nodaya.com



Nodaya Koriyama main store
 1-3-4 Honmachi, Koriyama City, Fukushima Prefecture
 Tel. 024-932-0254
 Fax. 024-932-0204
 Mail. koriyama@audio-nodaya.com



Nodaya Fukushima store
 2-8 Nishino-cho, Fukushima City, Fukushima Prefecture
 Tel. 024-535-5126
 Fax. 024-535-5370
 Mail. fukushima@audio-nodaya.com



Nodaya Utsunomiya store
 1-2-3 Mesugamine, Utsunomiya City, Tochigi Prefecture
 Tel. 028-614-1454
 Fax. 028-614-1457
 Mail. utsunomiya@audio-nodaya.com

Closed on Tuesdays, 2nd and 4th Wednesdays

Please see our homepage for more information.

<http://www.audio-nodaya.com>

Audio Day Search 

PRO SHOPA & P

Search for "audio repair" on Google
Displayed in BEST3 on the TOP page!!

Confidential

This month's special items

We offer "cash purchase" and "repair of famous machines".

"JBL and TANNOY" Edge special price repair

JBL 38~25cm
14,000 yen

Tannoy 38-30cm
Edge Harikas price
reduction ¥21,000
18,000 yen

2:300 units have been shipped!
We send you a shipping box.
安心の professional finish

TEAC A2300
86,000 yen

A&P Techno Center's high-quality measuring instruments
We repair with the spirit that there is nothing that cannot be repaired.
Please feel free to call us!

TEAC A4010 Reverse
100,000 yen

REVOX A77 III
300,000 yen finished!

TEAC X20R (1T2CH) Auto Reverse
140,000 yen

REVOX A77II (4TR2CH)
300,000 yen

TASCAM #112 professional cassette
キヌカ 65,000 yen

DENON #800 2TR20H 38-95
250,000 yen

MARANTE 10B vacuum tube tuner
450,000 yen

DYNCO Scandina 25 x Fully restored product
Pair 68,000 yen

DENON DH710F 38/2T38
yen

JBL+Tatematsu W woofer (1 piece 250kg) with 4WAY network
3,300,000 yen

Our company was interviewed in "JAZZ-JAPAN" #122 "I'm Karneoka, the president. Nice to meet you."

A moment of music...

Inside Casa de la Musica

DENON DH610S 2TR38
460,000 yen

KING OF AMP (World's largest)
Can be registered in Guinness

- ① Dedicated pre + 212 vacuum tube mono power
- ② All vacuum tube amplifier rose bush type 1500W+1500W
- ③ Power supply: AC200V-3P
- ④ Weight: 4:8TON for 2 units.
- ⑤ Our website: Uploaded to Youtube

5,000 for a pair Ten thousand yen!!

Casa Deramuzica Fukuoka Central Exhibition Hall opens
CASA-Della-MUSICA Reservations required. Please let us know by the day before!!

(New) (Display) (Used) Luxury bargain items in stock as of September 30th. We have 398 units in stock other than those shown. Please ask.

main amplifier		WILSON AUDIO SYSTEMS (List price ¥3,850,000) 780,000 yen (rare)
Waltersound MC 91B Mo2 units made by VEST 2,500,000 yen (rare)		JBL SBR: Olympus restored... .. 380,000 yen (overhaul)
HALCRO DMB60 (List price ¥3.8 million) Original 55x ¥1,450,000 (rare) with manual BLUJUS 4201 (Western 3008-274-310) Mo2 op., ¥2,000,000 (rare) 375 pair 380,000 yen (OH)		JBL K2: ¥9500. (List price ¥4.4 million) Restored... .. 1,400,000 yen (overhaul)
Q1 (A1008119) (GOLD-4011) pair made in Japan made in 188 (GEC) Ball power 80W+80W is the best 380,000 yen (finished) JBL 4343, Pair 260,000 yen (OH)		JBL 2440: Pair moving plate (new) 245,000 yen (rare)
Custom made 845 mono: Ball power 398,000 yen (OH)		SONY SWP-T1 driver only 1 pc. Original box, Manual 380,000 yen (rare)
GOLDMUND Miesis 9.2 MONO (List price ¥3.8 million) AC200V specification: ¥1,680,000 (rare) (TANNOY USA) SUPER 1000S RPH Pair, RED included, 1,600,000 yen (rare)		AUDIO MUSEUM 1000S RPH Pair, RED included, 1,600,000 yen (rare)
(rare) PEMEAJX (pro) SMO-PM235 RMC2350 (List price ¥800,000) HIFANCHOSET (rare) 1,500,000 yen (overhaul) (TANNOY USA) SUPER 1000S RPH Pair, RED included, 1,600,000 yen (rare)		ALTEC A71416-A/802-84/5158/8288-N501 Restored Pair 1,350,000 yen (good)
THRESHOLD Stasis 2 Power (List price ¥1,450,000) ¥350,000 (OH)		ALTEC A71416-A/802-84/5158/8288-N501 Restored Pair 1,350,000 yen (rare) a..
MCINTOSH MC24C OR Vacuum tube power... .. 480,000 yen (overhaul)		DIATONE 2S-305 pair 220,000 yen (good)
MCINTOSH MC2500 (BLACK) Power... .. 590,000 yen (overhaul)		DIATONE 2S-305 pair 130,000 yen (good)
MCINTOSH MC2500 (silver) Power... .. 650,000 yen (overhaul)		DENON DCSSA1 CD player with original box and manual (List price ¥950,000) 220,000 yen (good)
Ayre (Aura) V5 Power (List price ¥850,000) 350,000 yen (overhaul)		PHILIPS LHH300R CD player (list price ¥180,000) 92,000 yen (good)
CAS Amplifier BV100 200,000 yen (OH)		
AIRTIGHT ATM3 Mono Power Only 1 unit 420,000 yen (OH)		
YAMAHA W1 Compa-700 1,000,000 yen (OH)		
LUXMAN M030 50CA10 (with NEC) Vacuum tube power (overhaul)..... 102,000 yen (OH)		
QUAD QUADII Monoblock QM11 (good condition) KT88 250,000 yen (OH)		
Pre-amplifier		
MARK-LEVINSON LNP2L P1 1,500,000 yen (rare)		
MARK-LEVINSON NO-885 Pre-amp (List price ¥1,430,000) Base and Decoupling ¥1,180,000 (display)		
MCINTOSH C32 Pur 3,000,000 yen (rare)		
MCINTOSH C29 Pur WC included 3,000,000 yen (rare)		
LUXMAN A3400 Ball Pur 120,000 yen (OH)		
speaker		
JBL DESIGNER HARTSFIELD ORG 5,900,000 yen (overhaul)		
JBL 42719 (40cm wide) (rare) 1 piece only (List price ¥600,000) Large size 420,000 yen (overhaul)		
JBL 42719 (40cm wide) (rare) 1 piece only (List price ¥600,000) Large size 420,000 yen (overhaul)		

free main	SPARK EL34PP STEREO Vacuum tube type 120,000 yen (good condition)
recorder	MARANTZ 10B TUNER Vacuum tube type (2s 1s) 450,000 yen (overhaul)
	KENWOOD LOG TUNER 480,000 yen (overhaul)
	DENON DH710F Open (overhauled) Fully maintained 590,000 yen (rare)
	DENON DH610S open (overhauled)..... 380,000 yen (rare)
	DENON #800 Open (overhauled)..... 390,000 yen (rare)
	REVOX A77MK3 open (overhauled) 300,000 yen (rare)
	REVOX A77MK3 open (overhauled) 260,000 yen (rare)
	TEAC A2300 Open 86,000 yen
	NAKAMICHI #700 Cassette 100,000 yen (OH)
	TEAC No. 10 real adapter/pair (rare item)..... 3,900 yen (new)
cartridge	BENZ-MICRO Reference New needle tip 88,000 yen (overhaul)
	SHURE V15 (rare) only 1 crak SHELL included (rare) needle tip 6000 yen (overhaul)
	ORTFON MC-020 NEW Unopened (List price ¥75,000) Asking (new)
	DENON DL-102 NEW Unopened (List price ¥130,000) 47,532 yen (new)
analog play	EXCLUSIVE P3 analog player 650,000 yen (rare)
	EXCLUSIVE P10 analog player Yes 320,000 yen (rare)
	EMT (FRANTZ) #927 Analog player with stand TSD15 4,800,000 yen (average)
	ROKSAN TMSmk1 analog player without cover 780,000 yen (rare)
	YAMAHA GT2000L analog player 280,000 yen (rare)
	SAEC/SBX3-WE506 Super heavy with SP10MK2 750,000 yen (OH)
	VICTROLA Credenzel... .. 1,500,000 yen (OH completed)
	DENON DP7000 motor only, no seat... .. 32,000 yen (OH completed)
	DENON DP3000 motor only 32,000 yen (OH)
	MICRO (micro) BL91101/111 bell available Asking (new)
	SAEC-407-23 (micro) motor Capa table with 2 4,200 yen (new)
	SPU weight wait for YAMAHA GT2000 Solid stainless steel... 15,750 yen (new)

Audio number one
Call 21 PRO SHOP (株) PRO SHOP A&P
Please feel free to contact us! FAX (092) 784-2800
(092) 7-16-0002
= 2-1-29 Maizuru, Chuo-ku, Fukuoka 810-0073 ★Payment bank: Fukuoka Bank Akasakamon Branch (Public) 1717936 Pro Shop A&P Co., Ltd.



A 4-way speaker with four built-in D class power amplifiers that reproduces the overwhelming impact that you will never forget once you hear it, from the scale of the instruments to the tension of the performers. The ME800K, with its amazing power, is truly the flagship model representing Musik.

Low range 400mm cone/1000W/4Ω
Mid-low range 400mm cone/1000W/4Ω
Mid-high range 160mm cone/500W/4Ω
High range 25mm dome tweeter x 3-500W/4Ω

musik ME800K
Black ¥10,780,000 (pair)
Custom color ¥11,880,000 (pair)

Beyond time and space
be reproduced
The emotion of sound.

The birth of the next generation flagship speaker.

Visit our store and experience the sound of new speakers that bring together next-generation Yamaha speaker technology.



YAMAHA 3way speaker NS-5000
★Preview available ¥1,980,000*(pair)

Simple and good sound! We will advise you on how to use various popular Rotel products. Trial listening possible

You can listen to various models of Rotel products.

Integrated amplifier
A-11 **NEW ¥140,800**
cd player
CD-11 **NEW ¥107,800**

Preamplifier
RC1590MK2 **¥319,000**

Power Amplifier
RB1582MK2 ¥308,000
cd player
RCD1572 **¥176,000**

Other Rotel products available

Super special sale now!

yamaha tuning panel
A panel of only 3cm,
Creates a clear and comfortable acoustic space.

ACP-2 White Standard price 49,500 yen W587×H1200
ACP-2MN/MB Standard price 66,000 yen W587×H1200

Please contact us for price

[Our store is a Yamaha premium shop.]

Yamaha home theater now on **店頭展示中**
Various Yamaha AV amplifiers On sale at special price

RX-V6A 88,000 yen
RX-A4A 165,000 yen
RX-A6A 319,000 yen
RX-A8A 484,000 yen

New product Integrated flagship A-S3200 on display

A-S3200
Standard price: 737,000 yen Exhibition item special price

GT-5000
Standard price Black 825,000 yen Exhibition special price 599,000 yen

C-5000
Standard price 1,100,000 yen

M-5000
Standard price 1,100,000 yen

(*NS-3000, C-5000, M-5000 may take some time to be delivered.)

Various Yamaha audio products are on sale at special prices. Please contact us for details.

"The world's **SHARKWIRE VULCAN FUZE**
highest peak" Shark wire brings to the world "perfect conductivity" and "low impedance"
The ultimate pure silver fuse for audio that achieves "distortion elimination."
VULCAN FUZE Changes the freshness of the sound. Power amplifier, preamp, CD player, etc.
Various Can be used with audio products. 53,900
standard prices yen/1 bottle *Please contact us for details on how to use.

[Our own tune
onken original
speaker system
Equipped with TANNOY
unit iw6-SPAO1 ¥660,000
(Standard system)

Up! Original AO version]
Vacuum tube/passive system switching preamplifier
Natural-AOC3 ¥308,000 (standard system)
1000W with ICE power unit (42)
high power power amplifier
RB1092AO-LTD ¥660,000 (Standard system)

musikelectronic Historical monitor that reproduces even the finest sound of musical instruments
Since 1990, the German Public Broadcasting Federation has been using MEG (Musik Electronic Geyser) speakers.
Adopted as a standard monitor: In Germany, 90% share of monitor speakers in the broadcasting market
We are ensuring.

ME100 Custom color ¥572,000 (pair) Black ¥726,000 (pair) Custom color ¥858,000 (pair)

ME110 Black ¥1,056,000 (pair) Custom color ¥1,298,000 (pair)

ME150 Black ¥1,430,000 (pair) Custom color ¥1,694,000 (pair)

ME160 Black ¥2,178,000 (pair) Custom color ¥2,574,000 (pair)

uesugi Reliable sound UESUGI Various vacuum tube amplifiers

Pre-main U- BROS-660 ¥605,000
Buri U-BROS 2011P ¥616,000
Puri U-BROS-280L ¥715,000
Puri U-BROS-280 ¥825,000
Puri U-BROS-280R ¥1,078,000
Power U- BROS-120R ¥1,298,000

Special price on sale!

U-BROS-300AHP5
Standard price 1,408,000 yen

FURUTECH full tech
shark wire
nanotech systems

Special Blue Furutech NCF Clear Line
25,080 yen
Stesan limited special price

cd player
CEC TL3 ¥109,800
audiolab 8300CD exhibition disposal.....¥149,000

Analog player Thorens
TD309 White Disclosure penalty...¥238,000
Micro gunmetal turntable BL111L +
tone arm SME1012 volume with pump...¥698,000

Integrated amplifier
Luxman L-570... ¥118,000

preamplifier
Rotel RC1580MK2¥159,800
Luxman COB ¥169,800

Power Amplifier
Luxman M-08 ¥178,000

System
Pioneer S-1000TWIN ¥175,000
Diatone D53000 ¥178,000
Reprinted version with stand for AR AR-3... Yamaha ¥248,000
NS-F901 Display disposal ¥318,000
Infinity OMEGA ¥378,000
Diatone 253003 ¥899,000
JBL Everest
D55000 Box damaged... ¥998,000
WESTLAKEAUDIO BBSM15F .. ¥5,500,000
Standard price ¥12,980,000 Exhibition disposal special price

LINN
We handle various LINN products.
Not only DS but also speakers, Amplifier, analog player "LP-122"
Please feel free to contact us.

LINN network audio [DSM series] available. Please contact us for more information.

NEW KLIMAX DSM/3 LP122 analog player system
¥5,280,000

MAJIK DSM/4 New ¥638,000
SELEKT DSM-S ¥825,000
SELEKT DSM-K ¥1,100,000
AKURATE DSM/3 ¥1,210,000
KLIMAX LP12SE ¥4,158,000
MAJIK LP12 ¥572,000

Q Acoustics 3010i
White Black Walnut Various

Beautiful sounding compact speaker
"How about a subsystem?"

Limited quantity 29,800 yen (pair)

your good partner

Onken
Onkyo Giken Co., Ltd.

Business hours 11:00-20:00 (Closed on Wednesdays)

TEL: 043-224-7786

Advice on adjusting your listening room, etc. Please contact us even if you do not have a purchase/trade-in.

Used product information is being updated! <http://www.onken-audio.co.jp>

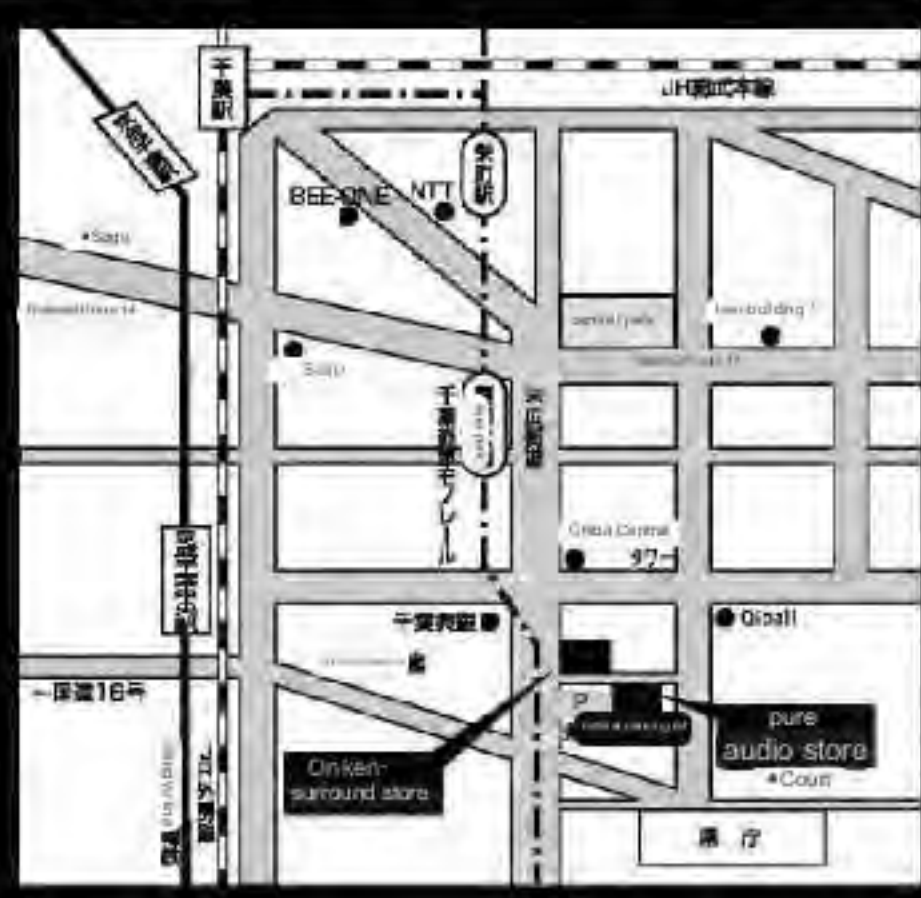



analog vintage audio

Free of charge nationwide in Japan

From Hokkaido to Kyushu and Okinawa, we are confident in our speedy response, which is possible because we have bases all over the country!

We also welcome "home delivery purchases" where you can have the product sent to you!



We are confident in the removal and transportation of large speakers!!



Reliable in-house maintenance facility



Number of reliable purchases



Audioland is chosen by people who value their audio.

In addition to estimates over the phone, we also offer online estimates that can be easily entered in just 60 seconds! Please also take a look at our official website.

0.0120-976-355

<http://audio-land.com/>



Business hours: 8:00 a.m. to 10:00 p.m.

24 hour reception

open all year round

weekly maintenance

audio land

search

AUDIO LAND Audio Land

[Speed support anywhere in the country!] Any audio related issue Operated Please leave it to us!
by: Tunagu Co., Ltd. [Tokyo No. 307770908096] [Osaka Prefecture No. 622301306352] Fukuoka Prefecture No. 901041510034

[Tokyo] 4-16-7 Meguro Honmachi, Meguro-ku, Tokyo 152-0002
[Fukuoka] 8-4-3 Arita, Sawara-ku, Fukuoka City, Fukuoka Prefecture 814-0033
[Sendai] 1-14-18 Honmachi, Aoba-ku, Sendai, Miyagi Prefecture 980-0014
[Hiroshima] 1-23 Hatchobori, Naka-ku, Hiroshima City, Hiroshima Prefecture 730-0013

[Osaka] 3-1-7 Torikaishita, Settsu City, Osaka 566-0071
[Sapporo] 14-1-1 Kita 2-jo Nishi, Chuo-ku, Sapporo, Hokkaido 060-0002
[Nagoya] 2-29-28 Meieki, Nishi-ku, Nagoya, Aichi 451-0045

audio high price purchase

From analog vintage audio to the latest high-end audio, we promise overwhelmingly high-value purchases.



Get a phone

quote in as little as 5 minutes!

•Home delivery estimate

No packaging required!

•On-site estimates

available nationwide!

I have continued to make serious purchases at high prices.

Trust × Track record

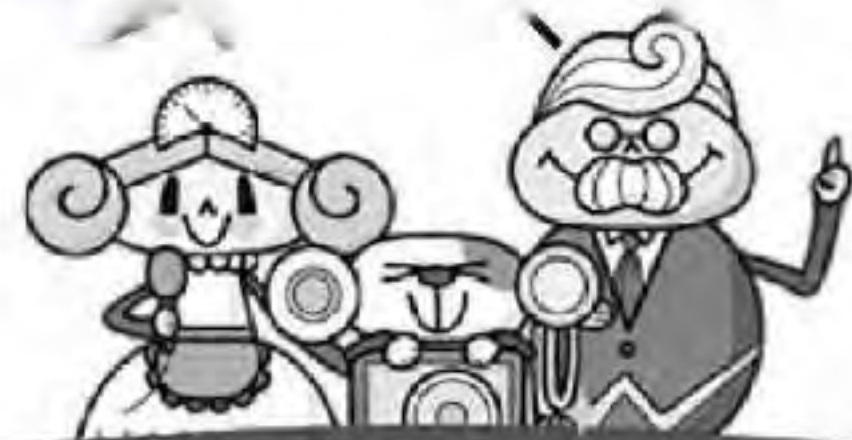

Thanks to you, the number of transactions exceeded 100,000 points!

When purchasing a new product, leave it to a

specialist purchase store rather than trading it in!

From large speakers and amplifiers to cables, we may be able to purchase them regardless of their condition, such as malfunction. Please feel free to contact us!

We offer an “unbeatable purchase price”!!

trend high end audio



Long-term relationship with good products

When you've been with a company for a long time, the problem becomes how to maintain it. When someone brings in a product from 50 years ago, the problem is that there are parts that need to be changed.

After 50 years, it is normal for a device to deteriorate. Even if you store it as new, it will deteriorate, and even if you perform maintenance using deteriorated parts, it will not return to its original sound and performance.

There is also the difficulty of deciding whether to maintain most parts by replacing them with the latest parts, or by replacing parts only in those parts that absolutely have to be replaced, and how the sound quality will fare even if the characteristics are now better than they were back in the day.

There must be fewer people who remember the sound of those days. I think it's become more and more romanticized in my memory, so if I listen to it calmly, I might wonder if it actually sounded like this. Some users say they want the sound to be the same as before, or even better, but what is the best way for you to maintain a long-term relationship with it?

Here are some products that caught my attention this year:

"Magico M9" speaker that costs over 100 million yen has finally arrived in Japan

"Esoteric Grandioso T1" Turntable non-contact Rotates with Magnedrive

"DS Audio ES-001" Set the record in the absolute center with eccentricity detection stabilizer

Although it is very expensive, it is a product that I am very interested in.



[Asahi Stereo Center Homepage]

We post used products, new product information, etc. from time to time.

<http://audio-asc.co.jp/>

Asahi Stereo Center Co., Ltd.

Nihonbashi 4-5-12/06 (6641)9694 (main) Closed on Wednesdays and Thursdays (reservations possible) / Business hours 11:30~19:00

I look forward to your success

air-tight

audio research

Avalon

AYRE

B & W

CHORD

Classe

d c s

DENON

DS Audio

ELAC

esoteric

ikedada sound

jeff roland

Krell

LINN

Mytech

Magico

martin logan

marantz

mark levinson

oracle

ortofon

plane tree

playback designs

QUAD

Ratok

Raidho acoustics

ScanSonic

SME

SOULNOTE

spectral

Wadia

WEISS

well tempered

wire world



ASC continues to be a specialty store filled with the joy of audio. Please feel free to come by.

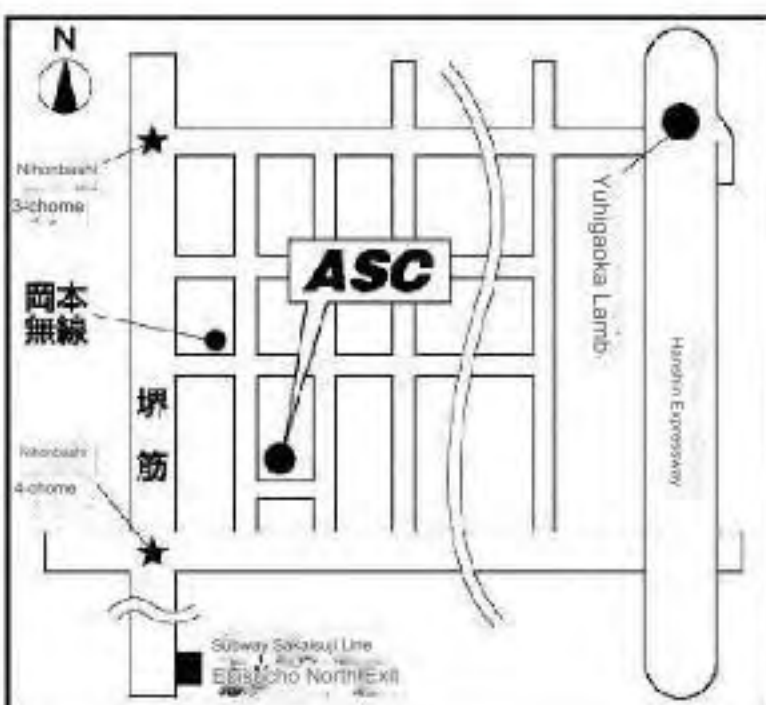

ASC

Naniwa-ku, Osaka 556-0005

Western Electric, from vintage to the latest audio home theaters

Aiming for quality sound!!!

SUPER QUALITY AUDIO SHOP

M's factory
authorized dealer

This issue's special selection!

Comparison
preview available anytime

You can listen to the popular M's Factory speaker units at our company!

MT-018 Treble



MH-048 Mid-high tone



MM-120 Medium tone



A high-performance model that inherits the lineage of ALE acoustics and GOTO units.

Mark Levinson



SACD Player No5101



PREAMP No5206



POWERAMP No5302

It cannot be said lightly that it is simply good value for money. An amazing high-performance model of the new Mark Levinson!



Paradigm
Persona B



DS Audio
DS-003



Phasemation
CHD-1000

We purchase Japanese-made record players, cartridges, arms, accessories, and other analog-related products from the 70s and 80s at high prices. Please feel free to contact us regarding products that have been rejected by other companies.

We will make a player cabinet. Detailed quotation for Garrard 301 and Torrence 124. You can listen to the popular Soul Note. Please contact us.

MUSIC & AUDIO

Microfarad

2F Akaike Building, 1-30-10 Hakusan, Bunkyo-ku, Tokyo 113-0001

Closed: Wednesday, Thursday

Business hours: Weekdays 12:00~18:00 Saturdays, Sundays, and holidays

11:00~18:00 Home page:<http://MICRO-FD.CO.JP/>

TEL:03-5802-7373
E-mail:micro-fd@nifty.com



3 minutes walk from Hakusan Station on the Toei Mita Line

10 minutes walk from Korakuen Station on the Tokyo Metro Marunouchi Line and Namboku Line

*We are often away due to deliveries, etc., so please contact us in advance when you come to our store and we will be waiting for you.

Tannoy three golden brothers.

-It doesn't make sense if Red and Silver blood doesn't flow through it.

Are there any other speakers who each have different meanings (expressions) like the three Karamazov brothers? Even though the speaker units are the same 15-inch Red and Silver...



•Autograph (15 inch Red 40,000 units) •My daughters' favorite room

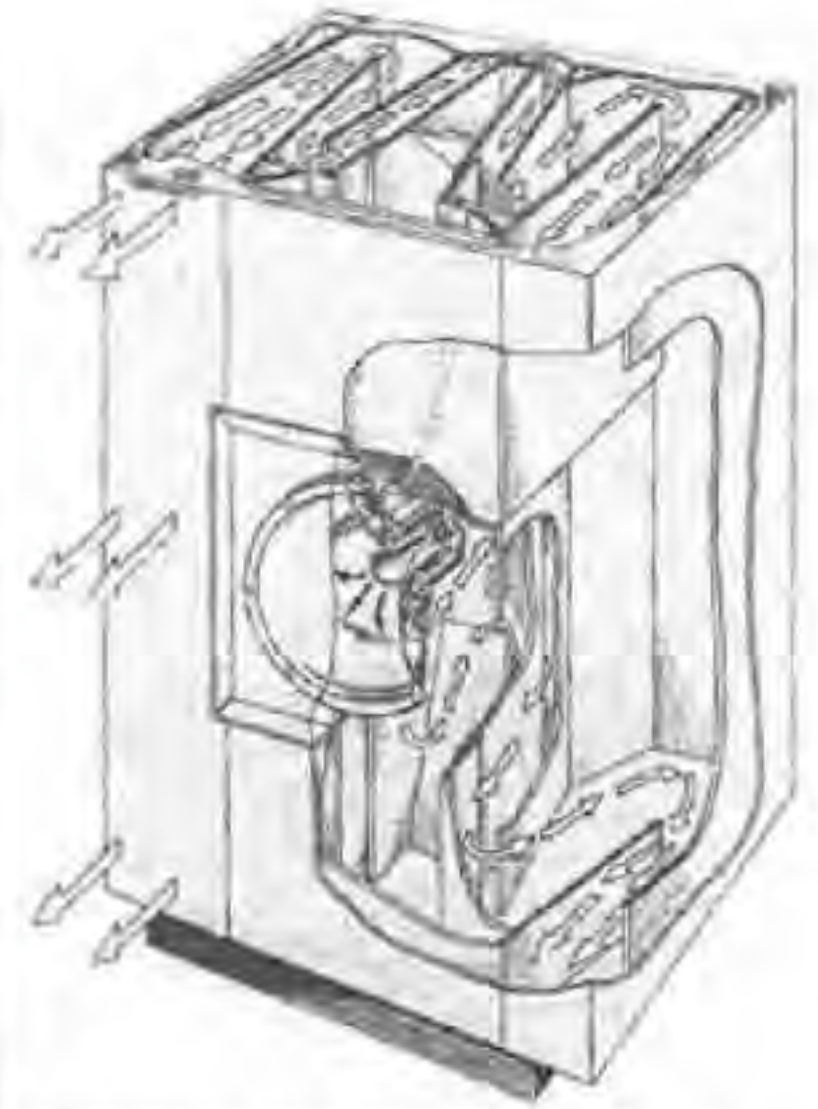

•Standard autograph (internal perspective view)
Height 1330 x Width 815 x Depth 560mm
Weight 130kg

•Incoming inventory

<Speakers>

Autograph (Red 40,000 units), G.R.F. (Red 40,000 units), Corner Yoke with Tripod (Red 30,000 units), Imperial (Red 2 each), Professional (Red 2 each), American Tannoy Standard Autograph (Red 30,000 units/American pine plywood early type), Corner Yoke with tripod (12 inch Red included)

<Amplifier>

Marantz #7 (within 11000 series), Marantz #9 (1000 series)

<Tuner> Marantz

#10B (1000 series/2000 series), Sequera Model 1 (panel champagne gold/Shurilo handling) Thorens

<player>

124, P.Clement (France) Early type (vertical) Late type (horizontal)

<Arm>

Ortofone RMG212 (old type) for upper pin (for G shell)

<Cartrich> Ortofone C-99A for stereo, C-99G HMV specification for monaural (red, green) A type, B type,

P.Clement Upper pin (first half) Lower pin (second

half) <Step-up transformer> J.S. (Denmark) Various

•No.224 Advertising homework, next time

•For the rest of my life, I am immersed in oil painting.

Approximately 600 oil paintings (numbers 4, 8, 30, 60, and 100) are stored at Nichinokan (Kobe City). Once the coronavirus is over, I'm dreaming of holding a solo exhibition in New York.

Kashihara Shrine (Nara) Sattahiko Shrine (Wakayama City), Hirota **をはじめ**, Shrine (Nishinomiya City), Kobe Shrine (Tatsuno City, Hyogo Prefecture), Haji Shrine (Tatsuno City, Hyogo Prefecture),

Komamiya Shrine (Nichinan City, Miyazaki Prefecture), Works have been dedicated to Nobuhara Hospital (Tatsuno City, Hyogo Prefecture/Orthopaedics), Hirota Dental Clinic (Kobe City), and

some nursing care facilities in Hyogo Prefecture.

•Information on the shy first solo exhibition of Hanju (81 years old)

— · Tokyo Ginza "Gallery Musashi" (1-9-1 Ginza, Chuo-ku, Tokyo) TEL. 03-3564-6348 FAX. 03-3561-6348

8 days from Sunday, March 19, 2020 to Sunday, March 26, 10:30 AM to 6:30 PM <http://www.gyarari-musashi.com/> From

- Soy Sauce Village "Taisho Roman Museum" (126 Kamikajo, Tatsuno-cho, Tatsuno City, Hyogo Prefecture) TEL&FAX.0791-72-8871

May 16, 2020 1 month from June 15th 10:00 AM~5:00 PM Closed on Mondays

gas light

3-10-11 Motomachi-dori, Chuo-ku, Kobe 650-0022 TEL&FAX.078-332-0130/078-709-7037 PM2:00~PM6:00 Closed on Sundays and holidays <https://www.gastokobe.com/>

Hichinokan (Art Gallery)

Sun Court Chidorigaoka 101&301&403, 3-21-28 Chidorigaoka, Tarumi-ku, Kobe 655-0011 TEL&FAX.078-709-7037

*Autograph (Red 40,000 units) is ringing at 101. JAZZ focuses on SWING, and CLASSICS focuses on French discs.

se B
EST DLNAUDIO
KEF Sonus faber

Sound Support

PS EAR TANNOY
LUXMAN marantz
JBL OCTAVE LINN

Long-term installment sales on popular items at special prices! Please contact us.

SALE 100 installments

The split fee will be borne by Sound Support.

No need to visit the store, more savings due to fewer visits, genuine new product. Can be used with bonuses. Please feel free to contact us with any questions. We also accept reservations. Shipping and installation fees are separate. Please inquire about items other than those listed. For more information, please contact us by email or phone.

JBL 4349



Speaker system (pair)
Suggested retail price
990,000 yen Down payment 0 yen Monthly 9,900 yen x 100 times

Sonus faber
OLYMPICA NOVAV



Speaker system (pair)
Suggested retail price
2,310,000 yen
Down payment 0 yen Monthly 23,100 yen x 100 times

Focal
Kanta N°2



Speaker system (pair) Suggested retail price
1,320,000 yen
Down payment 0 yen Monthly 13,200 yen x 100 times

ELAC
Solano FS287



Speaker system (pair) Suggested retail price
572,000 yen
Down payment 2,000 yen Monthly 5,700 yen x 100 times

Harbeth
Super HL-5 plus XD



Speaker system (pair) Suggested retail price
990,000 yen
Down payment 0 yen Monthly 9,900 yen per month x 100 times

DYNAUDIO
Special Forty



Speaker system (pair)
Suggested retail price
550,000 yen
Down payment 0 yen Monthly 5,500 yen per month x 100 times

KEF
Reference 1 Meta (stand sold separately)



Speaker system (pair) Suggested retail price
1,089,000 yen
Down payment 9,000 yen Monthly 10,800 yen x 100 times

TANNOY
Kensington/GR



Speaker system (pair) Suggested retail price
2,970,000 yen
Down payment 0 yen Monthly 29,700 yen per month x 100 times

SRULE P3



Preamplifier
Suggested retail price
1,848,000 yen
Down payment 8,000 yen Monthly 18,400 yen x 100 times

LUXMAN D-10X



CD player
Suggested retail price
1,430,000 yen
Consultation

OCTAVE V70 classA



Integrated amplifier
Suggested retail price
2,200,000 yen
Down payment 0 yen Monthly 22,000 yen x 100 times

Mintosh MA7200



Integrated amplifier
Suggested retail price
946,000 yen
Consultation

Levinson
lo.5805



Integrated amplifier
Suggested retail price
990,000 yen
Down payment 0 yen Monthly 9,900 yen x 100 times

CHORD DAVE



DA converter
Suggested retail price
2,420,000 yen
Down payment 0 yen Monthly 24,200 yen x 100 times

ESOTERIC K-01XD



SACD player
Suggested retail price
2,035,000 yen
Consultation

sfz DSP-Vela



Network Player 這帯昇
Suggested retail price
1,800,000 yen
Down payment 0 yen Monthly 19,800 yen x 100 days

Accuphase C-3900



Preamplifier
Suggested retail price 2,200,000 yen
Consultation

Accuphase A-75



Power amplifier
Suggested retail price 1,430,000 yen
Consultation

Accuphase DP-1000/DC-1000



SACD/CD transport
DA converter
Suggested retail price 2,860,000 yen
Consultation

Accuphase E-800



Integrated amplifier
Suggested retail price 1,133,000 yen
Consultation

Our mission is to be "real" and " Creating a sound space with a high level of natural balance

shipping
Kiyo Bank (Miyami Branch) (Public)
156826 Account Name Life Co., Ltd.
Postal transfer symbol 14740
Number 6843981
Account name Life Co., Ltd.

524 1714-1 Sakai, Kainan City, Wakayama Prefecture 073-487-5180
<http://sound-support.jp/> 073-487-5181
The homepage has been renewed.
We look forward to your call. Please also contact us by email.
AM10:00~PM8:00 Closed on Wednesdays

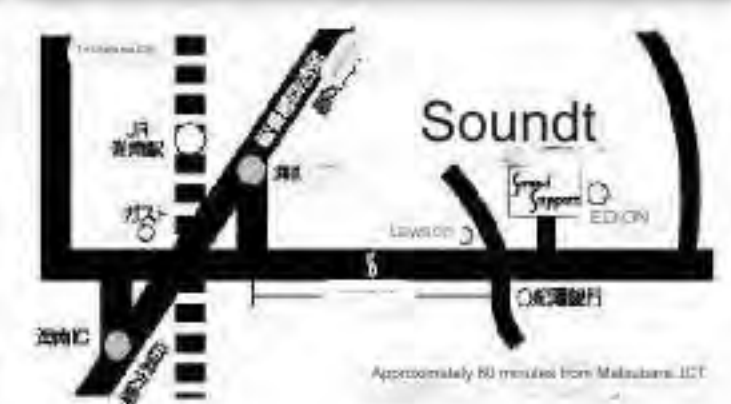



The destination is a silent SOUND

AUDIO NOTE

VERTERE™

**Fink
team**

LUXMAN



**Stereo Power amplifier
SOUGA**



**Magic Groove Record Player
MG-1 PKG**



**Loudspeaker
KIM**



**Belt Drive Analog Player
PD-191A**

We value the spirit of challenging ourselves to create the ultimate sound.

www.artcrew.co.jp

art crew

7-1-9 Nishijin, Sawara-ku, Fukuoka City

TEL.092-842-2555

FAX.092-842-2556



Art crew



AM11:00~PM5:00

In order to prevent the spread of the new coronavirus,
we have shortened our business hours on weekdays for the time being.

every Thursday Closed

Please sell your unwanted audio!

High-priced audio purchase

We are available nationwide, and all fees such as business trips, appraisals, and shipping are free!! We can purchase old and new models, tube types (your own creations are also accepted), large items, and even defective items!

We will travel anywhere for free!

Challenge to be No. 1 in the purchase price industry! Comparisons with other stores are welcome!

At High Sound, an audio specialty store, we offer three convenient purchasing methods!

☆Bring it to the store for assessment

☆ Nationwide business trips from Tokyo, Saitama, and Fukushima branch offices

☆ Convenient home delivery purchase with free shipping nationwide!

 **Bring-in purchase**

If you bring it to our store, we can appraise and purchase it on the spot. If the purchase is successful, we will pay cash on the same day.

 **On-site purchase**

Visit us at your desired date and time!
Free on-site purchasing available nationwide!
Our staff will handle the removal of items on the same day!
Payment will be made in cash on the day.

 **Home delivery purchase**

If you have the original box, you can use it, or if you have large or large items that are difficult to pack, you can easily ship them with Yamato Transport's "Rakuraku Household Goods Delivery Service" without the hassle of moving and packing!

Flow until purchase

1 Request an appraisal by phone or email

Please let us know the name of the manufacturer of the requested item, the model number, accessories such as the original box, and the condition of the item. Please apply for an online assessment by following the instructions on the web page.

2 We will inform you of the purchase amount.

We will notify you immediately of the purchase price of the item you informed us of.
Competitive quotes from other stores are also welcome.
Please feel free to contact us.

3 Pick up your items

If you are satisfied with the purchase price, we will collect the item using your preferred purchase method. Payment for home delivery purchases is made by bank transfer. Same-day cash is accepted for business trips and carry-ins.

Features of high sound!

At our store, we will inform you of the "purchase guarantee amount" and "purchase maximum amount" at the preliminary assessment stage via our toll-free number or online form.

We are informing you.

Have you ever had the experience of expecting a maximum purchase price and requesting an actual appraisal, only to be disappointed when the price was reduced?
This is our unique appraisal method that has been well received.

First, request an appraisal by phone or online!

Purchase: <http://highsound.net> Sales: <http://usedaudio.jp>

0120-083-084

Audio specialty store **high sound**
 Head office building: 350-0232 57-1 Nakatomicho, Sakado City, Saitama Prefecture
 TEL: 049-282-6805 Tokyo/Fukushima Branch office available
 Business hours: Open all year round 09:00~20:00
 (online assessment accepted 24 hours a day)  info@highsound.net

©When making an inquiry, please mention that you saw Stereo Sound.



Free appraisal!

The definitive M rack/stack type. 海苔屋が販売して早9年。 It has been used more than 500 times.



Three major features of Masteratsu Audio Rack

1 Strong weight makes it suitable for Japanese-style rooms and rooms with weak floors

2 The back side is completely free, making wiring easy

3 High quality unique to made in Japan

stack unit

MR-2202B

Base price ¥26,400 (tax included)

30mm thick MDF material matte black paint.

External dimensions: width 560 x height 220 x depth 440

Storage compartment internal dimensions: width 500 x height 190 x depth 440

stack unit

MR-2802B

Base price ¥28,600 (tax included)

30mm thick MDF material matte black paint

External dimensions: width 560 x height 280 x depth 440

Storage compartment internal dimensions: width 500 x height 250 x depth 440

Base
MB-02B

Base price ¥16,500 (tax included) 60mm

thick MDF material Matte black coating External
dimensions: Width 560 x Depth 440 Thickness 60

Please feel free to contact us! Weekdays 9:00-17:00 (closed on Saturdays, Sundays, and holidays)

TEL.048-982-1627

You can see the actual item below. (Reservation required)

83 Sakaemachi, Yoshikawa City, Saitama Prefecture 342-0050

TEL. 048-982-1627

FAX. 048-982-1688

↓ YouTube rack video



Seaweed Sommelier
Massy Channel



MASTAZ

audio project



Introducing the highest quality wartime

Furtwängler LP created by the Berlin Philharmonic himself! Completely

limited release of 2000 sets worldwide, serial number included.

Furtwängler Imperial Broadcasting Station Archive 1939-45

Berlin Philharmonic Orchestra
Wilhelm Furtwängler (conductor)

R. Strauss: Symphonic poem "Don Juan" / Wagner: Prelude to Act 1 of "The Meistersinger von Nuremberg" / Schumann: Cello Concerto [Tibor de Mahura (cello)] / Wagner: "Tristan and I... Prelude and Death of Love from "Solde"/Sibelius: En Saga Op.9/Beethoven: "Coriolan" Overture/B. Toven: Symphony No. 5 "Fate" / R. Strauss: Symphonic Poem "Till Eulenspiegel's Joy" / Beethoven: Violin Concerto [Erich Rehn (violin)]/R. Strauss: Home Symphony/Handel: Ensemble Concerto Op.6-10 HWV328/Mozart: Symphony No. 39/Weber: "The Magic Archer" Overture/Ravel: "Interlude" and "Battle Dance" from Suite 1 of "Daphnis and Chloe"/Ravel: "Daphnis "Unfinished" Suite 2/Schubert: Symphony No. 7 "Unfinished"

*Note: Despite careful remastering, the second movement of "Unfinished" contains background noise that cannot be removed.

Bonus

- Audio (13'27): Tonmeister Dr. Friedrich Schnapp speaks (Interviewer: Gerd Fischer/German Furtwängler Association)
- DVD (14'00): Berlin Philharmonic members talk about Furtwängler



8LP+DVD+High-resolution sound source/24bit remastered with download code

It is possible to download high-resolution sound sources (24bit remaster) of all sound sources included in KKC-5952 (22SACD Hybrid).

*Please check here for details •KKC-1201/8 (8LP) Imported disc with Japanese obi and commentary ¥46,000 (tax included)



KING INTERNATIONAL

•Purchase at Rakuten Market "King Inter Music Store Store"! <https://item.rakuten.co.jp/kinginter/>

アトリエ
(ジエティー)

Je-tee

Great Sound Collection

Bringing you masterpieces from the 50's and 60's! The ultimate vintage collection with beautiful designs.

JBL

Hartsfield

Early original model, early bubbleback 375, equipped with early 150-4C

¥ASK



Wharfedale



W-4 Airedale
Rare Alnico
38cm, model with
3way unit
¥880,000/pair

Jensen

TP-200 Upgraded to the A-15PM Type woofer installed in the rare Western 753C monitor. The realistic music playback, regardless of genre, is better than Western music. Please give it a listen.

¥1,680,000/pair



LEAK

stereo-50
6L6, KT-66, EL-34, etc.
can be used interchangeably,
25W output
¥530,000



Point-one stereo

The final type stereo preamplifier, the sound has less coloration and has a clear outline and resonates well.

¥290,000

(With dedicated power supply and dedicated cabinet)

Point-one mono

Early type preamplifier, LP is equipped with RCA RIAA/AES, COL/FFRR, NARTV/HMV, and also dedicated for SP records.

¥350,000/pair (with dedicated power supply and dedicated cabinet)



GARRARD

301 New custom made with cab, in excellent condition

¥450,000



Western Electric

WE 143B

This is a masterpiece of a high-power amplifier produced by Western, with a 6L6 parallel drive and 70W output, capable of playing even large model's speakers

¥ASK/pair

TANNOY



UK GRF R/Gold 15

A pair arrived in very good condition. The cabinet is made of high-quality birch wood and has a beautiful reverberation and high-speed sound that can be used in a wide range of styles, from Classic to Jazz.

¥2,400,000/pair



British original

AUTOGRAPH/Gold 15 has arrived after a long time. This is an extremely beautiful pair.

¥ASK/pair



RCA SL-123

A rare 30cm coaxial unit, the sound quality surpasses the LC-1A in terms of musical detail and

¥380,000/pair



RCA LMI 32216

British RCA original, equipped with KT-66 output tube, best match for TANNOY AUTOGRAPH GRF Masu.

¥1,200,000/pair

OCTAVE



V-40-SE

It goes perfectly with vintage speakers, and is a masterpiece with power and delicacy. It comes with a large main volume, so you can easily adjust two vintage monaural preamps.

¥858,000

TRU-SONIC



Model-629

The final model of the 1950s, a 38cm double woofer 3-way, unit-equipped model. Equipped with a large diameter woofer, it produces a clear and bright tone that is easy to use at high speeds, making it perfect for instrumental music and beat-based sounds such as rock and soul. It will also match well.

¥2,800,000/pair

We buy old and new audio at high prices.

If you live in a nearby prefecture, we will come to pick up the product. Please contact us for details.

Please match

Shonan Showroom: 0465-46-9575 (1PM~7PM)

647-5-101 Maekawa, Odawara City, Kanagawa Prefecture 256-0813

Check product availability and previews before visiting the store.

please confirm

<http://www.je-tee.com>

Not only the design, but also when you look inside.

And even when I hear the essential sound, I fall in love with it.

There are some fascinating audio devices out there. like this

What kind of person developed this attractive audio equipment? In this series, audio

critics interview the engineers and project

leaders who developed these attractive audio devices. Information on the person's upbringing, past career history related to audio equipment development, passion and high goals when actually developing audio equipment, and information used to decide on the sound.

He will tell us about the difficulties he encountered during the development process from his favorite CD. (Editorial department)



Luxman

Mr. Tatsuya Sueyoshi/Mr. Masakazu Nagatsuma

Mr. Yasuto Omori/Mr. Keita Kitazawa (SAEC)

Mitsuki Technology Mr.

Yasuyoshi Toki

Create and talk

Listener/Composition: Hiroji Onodera

LUXMAN

Mr. Tatsuya Sueyoshi

Mr. Masakazu Nagatsuma

Mr. Yasuto Omori

Mr. Keita Kitazawa (SAEC)

Don't fall into biased sound quality supremacy,

people in their lives

To enjoy music to the fullest

Never neglect "hobbyism"-----

that is the true value of Luxman



Luxman Co., Ltd. Representative
Director and President

Mr. Tatsuya

Mr. Tatsuya

Born in Kobe in 1966. When he was a junior high school student, he became fascinated with listening to Western music, including the Beatles, and became interested in audio. Eventually, I started using Luxman L570 and D500X's. His favorite performers include David Bowie and Paul McCartney. After graduating from the Department of Economics, Faculty of Commerce and Economics, Kobe University of Commerce, joined Alps Electric. Later, transferred to Luxman (1988) and was in charge of sales and product planning. Became Executive Officer, Vice President and General Manager of Sales in 2017, and became General Manager of Sales Headquarters in 2020. In March

Naudio brand representing Japan

oldest companies, will celebrate

its 100th anniversary in 2025. The after-

sales service is also generous, and they

take great care of their long-time

fans. They consider audio equipment to be a

hobby, and pay careful attention to

every detail, including its design,

finish, ease of use, and comfort.

Laxman's true quality is his

attitude. This means, for example,

carefully considering the shape

of each knob on the anbu, and in

some cases even redesigning it.

This is most clearly reflected in the "sex" aspect.

Of course, as we are an audio manufacturer,

the pursuit of excellent sound quality

is undoubtedly the most important thing

for Luxman, but we are also trying to avoid

falling into a biased emphasis on sound quality,

and to help people enjoy music to the fullest

in their lives. I have always admired the fact

that he never neglects his "hobby".

Among Luxman's new products, the one that

can be said to be the most popular is the

analog player PD191A. In my opinion,

this machine is truly typical of Luxman,

and is packed full of unique charm. So here,



People involved in the development of PD191A, Tatsuya Sueyoshi, president of the company, Masaru Nagare, who is no longer developing Luxman products, Omori, the engineer in charge of PD191A Mr. Yasuto and Saeku Commerce Co., Ltd., which jointly developed the tone arm installed in this machine.

We had one person, Keita Kitazawa, head of the group, come and talk to us. Development story of the latest flagship AD player PD191A Onodera First of all, PD191A

Saeku Commerce Co., Ltd. Representative Manager

Mr. Keita Kitazawa

Co-developer of tone arm LTA710 equipped with PD191A, born in Tokyo in 1962. Founded in 1974 (by his father, Kitazawa Taiten), he became the representative director of the company in 2005, and has been attracting attention for his development of PC-Triple C conductor audio cables and the WE4700 tone arm. Prior to that, he was involved in the design of individual residences and apartment complexes at an architectural design office. After that, he established an architectural design firm. His favorite musicians are TOTO, Larry Carlton, and George Benson. His hobbies other than audio include cars and skiing.

Chief Engineer Luxman Co., Ltd. Development Department Design Section

Mr. Yasuto Omori

Born in Tokyo in 1962. When he was in junior high school, he discovered a love for music in general (especially rock), and felt joy in being able to listen to his favorite music whenever he wanted. His favorite musicians include Robben Ford, Larry Carlton, and Toshio Kadomitsu. He also plays the guitar himself. After graduating from the Department of Mechanical Engineering at Tokyo Institute of Technology, he joined a major electrical manufacturer and was responsible for the mechanical design of commercial sound equipment and surveillance camera systems. Then, in April 2021, he joined Luxman's development department and was involved in the mechanical design of the M10X power amplifier and PD151M ARKII.

Luxman Co., Ltd. Director, Development Department Manager

Masakihito Nagari

Born in 1960. After graduating from university, he developed semiconductors and PCs at Tenshite Home Appliance Technology Research Institute of the Development Department. After that, he moved to Alps Electric and then to Luxman in 1987. The first product designed was the DP07/DA07 separate CD player, followed by the D500X's/D500X's II CD player, the DU10 universal player, the D08-SACD player, the L509s/L590A/L509u integrated amplifier, and the LMC5 phono cartridge. , the company's three major products including AD players since PD171A. Currently Director and General Manager .

Could you tell us about the

circumstances that led you to

develop it? Sueyoshi Laxman

to put down analog player again

It started with PD171 released

in 2011. Before that, we

had developed a number of

products in the 1970s and

1980s, but that stopped for a while.

It's ke. After

the PD171, there was the improved

model PD171A and the armless

type AL, the younger brother

PD151, and the new model that we

worked on for the first time in a while.

However, the phono car

We have released products

such as Torridge LMC5.

Thanks to all of you, we have

received high praise for all of them, but

due to various current circumstances,

unable to procure necessary materials and parts

When it comes to analog players,

we are faced with the prospect of not

being able to produce the same product.

did. Production of PD171A was completed the year

before last, and parts for 151 were no longer available.

Production has also been completed. So 151

arrived at Fukira as a marxo model, and 171

A has been completely revised, the model number

has been changed to 191, and an analog player

berfiling the new flagship model has been developed.

I decided to do it. Nagatsuma:

Since I restarted the development of analog equipment,

I've created about 10 products, making the most of the

technology and knowledge I've cultivated over the years.

This is PD191A. Of course, it

follows the excellent features of the

PD171A, such as the belt drive system.

The high-mass platter, its spindle and bearing

structure, the material and thickness of the highly

rigid top plate, and the intersection of the arms

They are the same in terms of being interchangeable.

On the other hand, everything else is a new design,

or to be more precise, the motor is a PD151.

Although it utilizes similar products, the drive circuit

is new, so in the end, I think it's fair to call it a new

product that has been completely revised. It costs money

to use new parts, but each time you use new parts,

you have to spend a lot of time on the mountain.

I had them come up with a budget

(lol). Sueyoshi Imagawa: My biggest job

was probably stamping stamps (lol). Nagatsuma:

And one of the most important

points about this machine is the tone arm.

However, I believe that thanks to

Mr. Saeku's full cooperation, we

were able to create a wonderful arm.

latest model



AD player PD 191A ¥900,000

The tone arm installed in the company's top-of-the-line AD player, released in September, is the 10-inch version LTA710 developed jointly with SAEC, known for the WE4700 arm. The vertical bearing has a single knife edge mechanism (the horizontal bearing is a bearing type), adopted. This arm pursues high quality signal pickup with high precision and robust construction. The drive system is a belt drive type using a high torque brushless DC motor, and has a unique sine wave PWM/PID control force type and excellent temperature characteristics. By using a speed compensation reference clock using a MEMS oscillator, accurate rotation performance is maintained. Matsu The number switching is in three stages: 331/3, 45, and 78 rpm, and each can be finely adjusted.

vinegar. Whatever it is
If so, I wanted
to install a completely
newly
developed tone arm.

It is.

Sueyoshi: You
could say that the
tone arm is the most
important point in
this development.
I think it's good
vinegar, because,

It is not easy to design and develop
a system from scratch. Meanwhile,
a voice from Mr. Luxman
When I received this, I thought I
could create a new tone arm. I
was given a very good opportunity.

Well, once we actually started,
there were some challenges in terms
of cost and delivery, but I'm
really glad we did it.

Onodera: How did you decide on the
tone arm specifications?

Kitazawa: The length of the tone arm is
The basic requirements were based on
Mr. Luxman's requests, such as using a
10-inch type to reduce the king error,
and using a knife edge (vertical) bearing
system to maximize sensitivity as
much as possible. Because of this,
development went smoothly in some places.
I will.

Nagatsuma: By becoming shorter and losing mass,
I considered a 9-inch type that would give
higher sensitivity, but I decided to go with
a 10-inch one to balance things out.

Kitazawa: However, since the dust cover is
available as an option, it was absolutely impossible for
the arm to protrude to the rear, so there were restrictions
on the dimensions at the rear of the rotating shaft.

Completely new development costs a lot
of money. However, we want to keep the
price of our products as low as possible.
I am truly grateful to Mr. Saek for his
cooperation under such difficult conditions. Mr.
Onodera Kitazawa opened the tone
arm from Luxman under strict conditions.
How do you feel when you are asked to speak out?
Did you get it?
Kitazawa: Honestly, I was very happy. We
make tonearms under the Hakusha
brand, and of course we take pride in their
performance and sound quality, but in
today's world, when we think about business,
we need new, full-fledged tonearms.

This is a strong point, and that was a point where I had a lot of trouble. Since the rigidity and precision of the bearing are the most important aspects of a tone arm, we carefully examined the material and shape of the knife edge and receiving side, and by integrally molding them to improve precision, we were able to create a tone with extremely high initial response sensitivity. |

think it's an arm. Onodera: The arm pipe is aluminum. Kitazawa: We chose aluminum for its tone and workability. Moreover, the main parts such as the arm pipe base ~ bearing support part ~ counterweight side shaft are also made of aluminum.

The body is molded to ensure sufficient rigidity, which is important for sound quality. Nagatsuma Also, since aluminum is a light metal, the upper part of the receiver is lighter than other receivers, which should also contribute to high sensitivity. Kitazawa: I think it was a pretty good product from the first prototype, but from Luxman, for example, inside four After receiving feedback such as wanting to be able to make detailed adjustments to the scan cellar and lateral balance, or pointing out minor changes in the design, we were able to achieve a product that was satisfactory in terms of performance, design, usability, and sound quality.

White is negative. Performed detailed sound quality tuning including improving S/N Onodera: Please tell us about the features of the turntable. Omori Changes from PD171A I think it's easier to understand if we start with the basics, so I'll explain it accordingly. First of all, 171 is main on the top plate. I was installing parts, but 19 In 1, the motor and power source are the vibration sources.

Move the transformer to the bottom chassis. We tried to improve the S/N. I think this is the difference in terms of structure. The motor is an AC motor or a brush that has a proven track record in P D151/MKII. We have optimized it for the PD191 by changing it to a DC motor and reviewing the drive circuit, including the power supply. Nagatsuma: There are some advantages to attaching the motor to the Top Punto, for example, it is easier to position the motor that way. The opposing platter is placed on the top plate.



The main parts (spindle, platter, tone arm) are attached to a 15mm thick top plate, and an underslung structure is used in which the main parts (spindle, platter, tone arm) are connected to the ground through the control insulator legs. In addition, by floatingly mounting the drive motor and power transformer on a newly installed 3.2mm thick bottom chassis via vibration damping rubber, the signal pickup mechanism is separated from the vibration line, resulting in mechanical S/N (rumble). Improvements have also been made in howling performance.



The receiving part that supports the heavy-duty platter has a 16 mm diameter, hardened, stainless steel spindle shaft with a ball bearing fitted into the lower end, and a spindle shaft made of PEEK (polyetheretherketone) with excellent wear resistance and load capacity. A combination of a brass thrust bearing and a brass radial bearing filled with organic molybdenum oil is used. |



A one-torque brushless DC motor drives the heavy-duty platter via a belt made of E PDM (ethylene propylene TR), which is resistant to aging.



A 300-diameter platter machined from an aluminum block and machined with precision machining. Thickness: 35 mm, weight: 5.2 kg. A strobe pattern with a striped pattern is engraved on the outer periphery of the back of the platter. It is.



The arm base (common with PD171A/AL month) of PD191A is replaceable and can be used with various tone arms. (9~10 inches) can be installed. There is also a 12-inch tone aperture attached to the rear of the main unit. -An external arm base for mounting the arm is also available separately (the first one is for SME3012).



Equipped with LTA710, developed in collaboration with SAEC, a long-established tone arm brand. This arm is a 10-inch static balance type arm that features a knife-edge mechanism for the bearing that offers excellent initial motion sensitivity.



The main parts of the LTA710, including the arm pipe base, bearing branch, and counterweight side shaft, are integrally molded from aluminum, and the rigidity, which is important in terms of quality, is also ensured.



The receiving side of a knife-edge bearing (the V-shaped concave part). This is where the wedge-shaped knife edge, the cutting edge, will be transmitted (see enlarged photo above).



Engagement of the knife edge soft receiver. [Photo (cylindrical exterior has been removed).]

That's why. Omori: However, when we installed this on the bottom chassis, new problems arose, such as the pulley not being able to align easily with the platter during assembly.

Nagatsuma: By housing the motor in the bottom chassis, we were able to achieve the intended noise reduction. However, the wow and flutter became worse. When I investigated why this happened, I found that the motor

was tilted only slightly. There is a gap near the motor on the bottom chassis, but this area is the result of repeated trials.

Sueyoshi: I wanted to make the proportions as beautiful as possible, so I decided to change the overall height of the product. I had limitations. I think there were some design difficulties in that area. Onodera: I think the tone arm and turntable were developed at the same time, so the program for developing the tone arm was

You used PD171A for the platform, right? That's right, my long wife.

Since you were Onodera, you probably couldn't hear the sound of the combination of the two until the very last minute, but what were your impressions when you first heard the prototypes together?

Nagatsuma: That... it wasn't good. (lol). The tone arm was developed after checking the sound with the 171, so there shouldn't be any problems. However, when developing a turntable, we first tried to compile the specs, and at that stage we didn't really consider the sound quality. Since there was no one there, it is natural to say that Maybe it was natural.

Onodera: Many people still misunderstand that as long as a turntable rotates silently, silently and with high precision, and is free from vibrations, that's all there is to it. That's not enough for an audio product, as it rotates quietly and precisely to eliminate the negative effects of vibration.

This is just the starting point. Nagatsuma: That's right. There were times when I thought that my heart would just stop and just let things spin, but when I was actually involved in product development, I realized that even the smallest things would happen.

In the face of constantly changing sound quality, I realized the importance of consideration.

Onodera: What kind of sound quality tuning did you do with the 191?

Nagatsuma: First, we are reviewing the motor drive circuit board. We use a power transformer that can supply sufficient energy, so we have made sure that it can be transmitted to the motor without loss.

Omori: Just make the casing more rigid.

It's not about saying it's good, it's about measuring and listening. I am finding the right amount of softness in ^{wedges}

Nagatsuma: We reconsidered the oil used for the center spindle of the platter, and are using one with a higher viscosity than 171. is.

Onodera: Oil and grease change the sound and sound. It's not just that there should be no friction.

Omori Also... Actually, we increased the diameter of the recess in the center of the turntable seat by 3 millimeters. This itch is to remove the thickness of the label surface of the encoder, but since there were a small number of records where the label protruded, I tried widening the dent. In that case Yes, those who like the sound of other records as well.

Program source used when deciding on sound

Luxman



On Music - Schubert
Recital
Elly Ameling (S)
(Philips)



Beethoven: Piano Sonata
No. 17, No. 16
Emil Gilels (p)
(Gramophone)



the hunter
Jennifer Wames
(Impex)



Nightclubbing
Grace Jones
(Island)



Brothers in Arms
Dire Straits
(Warner)



Vivaldi: Concerto Collection
"The Four Seasons" Arthur Grumiaux
(vn), Arpad Gerets
soloist Romande
(Philips)

SAEC



We Get Requests
Oscar Peterson Trio
(Verve)



Teddy & Eiji -Live Session
Teddy Wilson (p), Eiji Kitamura (cl)
(trio)

the seat has changed for the better. a shape. As you can see the difference, you can hardly hear the record. It has By widening the recesses, I think to let go of the front in 191. Onodera: Nagatsuma: Also, I guess it became easier to the main body chassis. wood panels to attach the wood panel back of these screws are decorated with Bene screws, and the metal parts on the to use, I attach them with Noisin When deciding where and how many The rules will change. Onodera: That's a fairly low level of noise.

That's right. environmental noise is reduced. microvolt level measure noise during the night, when the method. Nagatsuma: Yes, Omori and I I went back and decided on a screw-fastening Sueyoshi: Did you go so far as to do that? I didn't know that at all (lol). performance and sound quality. sound quality was determined by width became too large and the panel in an area where the Design I wanted to install a wood be unfavorable. Performance and balance, only the front side will

I chose this single wood panel. to the music. I thought it had great meaning. Onodera: Onodera: I put on a record and listened an atmosphere suitable for a piece of equipment. to bring it out. The sound quality creates the music, it is because they can be manipulated with the feelings of the person listening to and although it may have nothing to do mind changes, the sound will sound different, arm. Also, PD191A is available. If your changing the cord and raising and lowering the perform a series of movements such as A, and comfortably. This makes it very easy to Many analog devices can be used casually

one-on-one performance on Ru Point of the PD191A are pretty much you very much. Recently, Laxman's the same as the 171. think. Sueyoshi: Thank tax, but I think the contents ended up being quite expensive, including though I was working hard on it, it able to keep it within 1,000,000 yen. Even for as many people as possible, and I was live a rich musical life. I was able to use it I hope so. It will help you product, Luxman will continue to do so. Looking forward to creating a hobby is. Onodera:

Create and talk

Listener/Composition: Hiroji Onodera

Kojo Technology

Mr. Yasuyoshi Toki



Seiji Mitsuki Co., Ltd. Director, Power Supply Division Manager [Yasuyoshi Gi]

Born in Aomori Prefecture in 1968. Regardless of the genre, I like music that moves the heart. Other than audio, my hobbies include design and fashion. My special skills are skiing, drawing, and cooking. In terms of my work, I utilize the research results of SIT (Shizutsu Induction Transistor). In 2004, he joined Mitsuki Seiko in 2004 after commercializing audio clean power supplies. Assigned to the newly established power supply division, he developed clean power supplies for audio and virtual earthing. In addition, as "Captain John Garu," he is actively involved in public relations activities, taking care to use events and SNS.

U

In Issue 219 of this magazine, "(tentative)

I had an article published titled

"Story about Earth, etc."

The reason I wrote that it

was published was because

the editorial department didn't

ask me to write it, nor did

anyone ask me to do it, but

because something particularly

interesting happened

while I was enjoying the audio at

His house. So I asked the

editorial department to give

me some space. Most readers

If it is a virtual earth,
Can be connected close to the amplifier, etc.
Sound quality can be improved.

The impedance per area can also
be lower than that of the ground.

What I wanted to share with you was

the (true) fun of audio, which involves

thinking things through in your head

and trying things out, but what I was

trying out was... It was "Virtual Earth

Crystal E" by Mitsuki Seiko (Kitsuki

Technology).

This was the first time I had introduced

a virtual earth, and I bought the Crystal

E without knowing much about the

manufacturer Mitsushiro Seiko. And on

my system, it worked very well, much to

the credit of the product developer. This

machine has a great reputation in the market.

Virtual Earth/Crystal E



Kojo Technology Crystal E Y34,400
Crystal Ex2 Y62,000 (set of 2)

External dimensions: W80 x H35 x D111mm - Main weight: Approx. 775g

The catchphrase is "A closer earth than a distant earth." Crystal E is the second virtual grounding device that aims to reduce noise by grounding (grounding) the audio equipment close to it (impedance approaches zero ohms and obtains a more stable reference potential). Adopts a laminated structure of different metals that further develops the concept of the first-generation Force bar EP. In addition to increasing the area per layer, a 0.5mm space is provided between each layer of the 8-layer structure to avoid surface contact between layers. It is said that it has an area approximately 1.75 times larger than that of a combat aircraft. This is to create a conductor that is sufficiently quieter than the ground of the audio equipment's white body, and to obtain a more stable reference position.



Inside the Crystal E, there is stainless steel, SUS, brass, copper, brass, copper, No layers of British copper, copper, and copper. Adopts an 8-layer configuration, this material Selection and stacking order take a long time. Through repeated trial and trial listening It has been decided. a on the top cover, Lumi, steel on bottom chassis (both 2mm thick), and The lower center of gravity also improves sound quality. It is said to be connected to the top.



Crystal E can be expanded like previous models, and further improvements in sound quality can be expected. When expanding, use the separately sold ground cable (Y terminal - Y terminal, cable shown in the photo).

(This is a reference example), from the ADD E terminal of the 1st unit to the FROM EQUIPM of the 2nd unit. Connect to ENT terminal

Could you tell us about your background before joining the company?
Toki: I grew up in Aomori Prefecture. I also like music, but I have had a strong interest in electricity and machinery since I was a child.

The company's new generation virtual earth product, "Crystal EP," has become popular and remains a bestseller.
 Announced: Taking advantage of this opportunity, Mitsuki Seiko will hold a virtual I decided to meet with Yasuyoshi Togi, who is responsible for the development of various products including Earth, to hear his story.

I don't think you're that familiar with the manufacturer Mitsuki Sei, so first of all, could you tell me about the background of the company that developed Crystal Vi&EP?
Toki: Our company was established in 1990 in Hirakawa City, Aomori Prefecture. This started with subcontracting work for manufacturers of inspection equipment for semiconductors and liquid products. In fact, Hirakawa City has many companies in the secondary industry. Since then, we have specialized in the design and manufacture of

Onodera: Like me, readers of this magazine

precise and precise products, and this is why we are here.

Current number of employees is 4
 Become.

Another important business is LED lighting, which is used for surgical operations.

power supply division. Onodera: Before we talk about virtual earth, there is one more thing.

After testing equipment for semiconductors and liquid products, our next project was assembling digital cameras. We created a zoom lens unit for a famous brand and a viewfinder unit that doesn't exist anymore (lol). Although I cannot do optical design, I am good at manufacturing lens barrels with complex mechanisms. Producing probes for testing semiconductors and liquid products requires precision down to the micron level and requires a certain level of craftsmanship, but he says that the techniques he has cultivated there have been of great help.

Operating room lights and operating room lighting control We are also involved in medical equipment. All of these products require a power source, and the quality of the power source is extremely high. Therefore, we established a power supply division to develop and manufacture power supply-related products, and gradually expanded into the audio field. Currently, power supply/LED/miscellaneous goods/precision The company handles original products such as sensitive equipment and OEM, and I am the manager of the power supply division, and the virtual earth was developed by the

Virtual Earth/Crystal Ep Series



Crystal EpR Y24,000 with RCA plug

Crystal EpT3 Y24,000 with \$3.5 stereo mini plug



Crystal EpB Y24,000 with banana plug

Crystal EpY Y24,000 with Y lugs (M4-M8)

The latest ultra-compact plug-type virtual earth device designed based on the diameter of a typical RCA plug houses a special wire capacitor whose conductor is a band-shaped high-purity aluminum wire. The conductive surface is specially etched to form countless cavities resembling a spongy structure, resulting in a large conductive surface area of 11,000 cm² (110 cm x 100 cm). There are four models in this series with different terminal shapes as shown in the photo, each consisting of three pieces: plug, body, and cap. Each plug has an M5-sized male and female screw mechanism and is removable, allowing for replacement with other plugs, use with other virtual grounding devices, and expansion.

Internal structure of Crystal Ep series

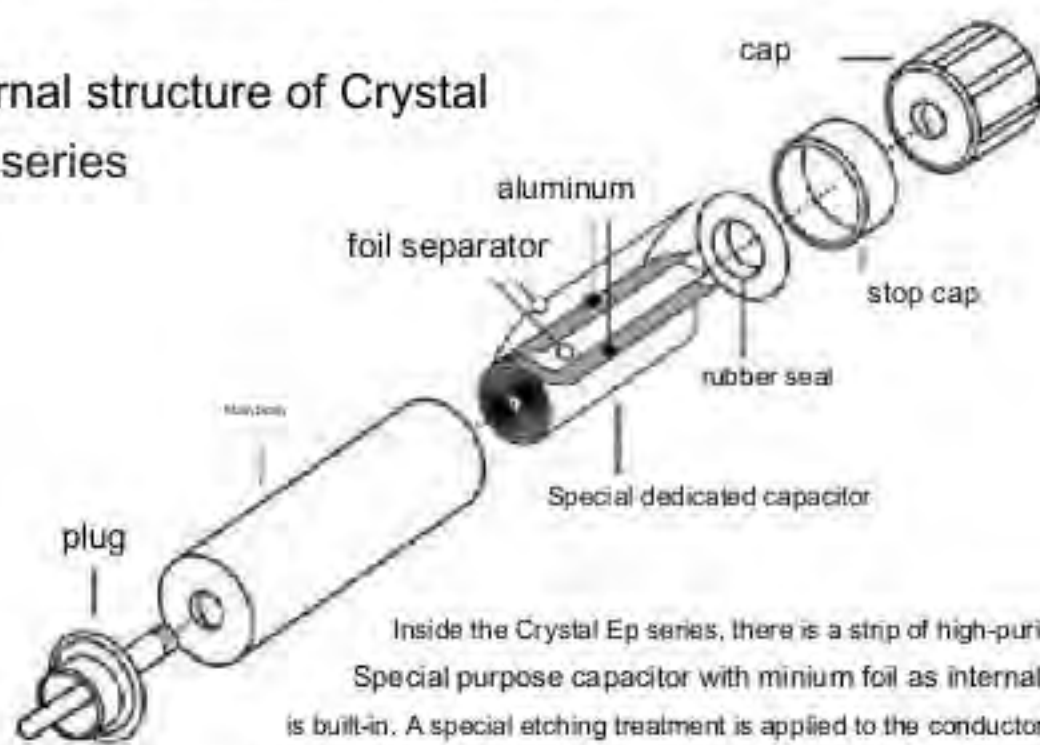

Inside the Crystal Ep series, there is a strip of high-purity aluminum. Special purpose capacitor with minium foil as internal conductor is built-in. A special etching treatment is applied to the conductor surface. By doing so, it forms countless cavities resembling a spongy structure, and is said to have obtained a conductor surface as large as 11,000 square meters (110 cm x 100 cm).



Crystal Ep series are connected as shown in the photo. By using Double the body area 22,000cm² (220cm x 100cm) and can be used as a virtual ground further enhance the effectiveness of becomes possible.

With that in mind, I enrolled in the electronics department at Hirotsaki Prefectural Technical High School, and after graduating, I got a job at a local electronics company. I actually wanted to do research related to electricity, but luckily my company sent me to the Semiconductor Research Institute (Sendai) of the Semiconductor Research Promotion Association. This is one of the world's leading research institutes, where the late Professor Junichi Yosuzawa, who invented the static induction transistor (SIT), was the director. Here, we will conduct research on the application of SIT to power supply circuits.

I was able to engage in this, the study

A representative large company in Japan is dispatched to work on the project.

There were many people who were affected.

After that, I had no choice but to change jobs to a company in Aomori City, but the experience I had at that time As a result, we were able to commercialize an uninterruptible power supply (UPS) for physical and chemical equipment. We also develop and sell clean power supplies for audio. I learned everything from product planning to mass production of products, including basic experiments, design, parts arrangement, and inventory management. That's right, record Also used as a clean power supply for the ding studio. I have worked as a recording engineer. Mr. Hiroshi Namekata, teacher and critic Takuya Inoue, scrubbed even in the river of sound creation.

It was also a very good experience for me. I did. Mitsuki Seiko had a relationship with this company in Aomori City as it had been contracted to manufacture them, and we have been working here since 2004. One of the deciding factors in my decision to change jobs was that the president seemed like a fun person. Our power supply division was born at this time.

"Virtual Earth"

By increasing and strengthening the ground area

Things that improve sound quality

Onodera: Mr. Toki from the Power Supply Division, why did you decide to develop a virtual earth?

Toki: I mentioned earlier that any electrical product has electricity.

I mentioned that a power source is necessary, but what is absolutely necessary for an electric circuit is an earth. In that sense, I was also interested in improving earthing, and that's when I discovered the genre of virtual earthing. It was a product of

Generally used as ground for electrical circuits.

It is the metal chassis of the housing that is connected, but I (our company) believe that the virtual earth is connected here to increase and strengthen the ground area, thereby improving sound quality. is, earth As the name suggests, the larger area is the earth, or human land. The method of improving sound quality by grounding has long been known, but the distance between the housing and the earth is quite long. There is a problem with this. However, if it is a virtual ground, it can be directly connected to an amplifier, etc. By placing it nearby and connecting it, you can strengthen the grounding, and in terms of impedance per area, it can be lower than that of the ground. Continuity is also important. Our first commercialized virtual earth "Force Bar E" released in 2016

Use when deciding on the sound program source



Crimson Wings—Mystery Flamingo
The Cinematic Orchestra
(Disney)



SOUL JAZZ BEST 2020/
MISIA (Ario Japan)



ROADHOUSES & AUTOMOBILES
Chris Jones (Stockfish)



Destiny Celtic Woman
(Manhattan Records)



Keep On Moving ~Best of a
Njerik Kijo (Wrasse)

"P", we were able to hear feedback from users about the surface area by I earned a product and chlorinated the ground. The "Crystal E" advances this idea, greatly increasing the effective surface area while being compact, and further examining the combination of metal plate materials to further tune the tone. Strangely enough, the sound quality changes not only by the size of the surface area, but also by the type of material used. Of course, the connection cable also changes the sound. Onodera: I experienced that too.

The latest Crystal EP is small and requires no connection cables. You can experience the virtual earth effect more directly.

Toki: I was happy to see you write that in the article. Thanks to everyone's support, "Crystal E" has become a huge hit, with many

laminating metal plates. There were many requests for a smaller size, and in response to these requests we created the new product "Crystal EP", which can be called the second generation of our virtual earth.

Having said that, the mechanism is simple, and it has a huge surface area of metal with a small footprint. While I was thinking about what would require etching to increase the surface area, I came across an electrolytic capacitor. Inside is an electrolytic capacitor itself (*Uses the capacitor's electrode-capacity and does not have a capacitor function). Before making the prototype, I tried connecting an electrolytic capacitor that I found around to the ground of the amplifier, and noticed a surprising change in the sound quality.

The size of the surface area affects the sound. I think.

The reason why I'm revealing the details in such a simple way is because I think it would be interesting for those who are interested to try it out, and I think that doing so will expand the ways in which you can enjoy it. And of course, the effect is different from that of "Crystal EP."

As you know, electrolytic capacitors are Masu. The apparent area of the aluminum foil in Crystal EP is only 10 cm x 10 cm, but by adopting a spongy structure, the effective area is more than 100 times larger, 10 cm x 100 cm. In addition, the structure does not require any connection cables, so you can experience the effects of virtual earthing more directly.

Actually, why is virtual earth good?

It has not been completely proven theoretically or electrically. As an engineer myself, I try to explain as much as I can, but to be honest, I feel frustrated. I wonder if it's seen as a somewhat occult product. However, I believe that in the future we will be able to theoretically explain the effects of virtual earthing, and I would like to continue to develop better products related to virtual earthing and power supplies.

I decided to introduce "Crystal ED" in parallel with "Crystaldo," but as Mr. Toki said, its effects are great, and because the effects are so great, it's difficult to make the most of them. Once again, I am having fun with different connection locations and methods.

Rin's featured new products

“Select DSM Edition Hub”
ask about the concept

Mr. Gillard Tiefenbrunn
Mr. Steve Croft



Export Sales Manager Steve Croft

The year before last, the bearing system (carousel) of the turntable “LP12” was renewed, last year’s announcement of the top-of-

the-line network player “Climax DS M/3”, this year’s new tone arm “Arco”, and the top-of-the-line “Ecstatic”. Starting with “Kendo”

and “Coil”, a total of three MC-type phono cartridges were released...and this fall, this one...and this fall, this one too. Linn Products of Scotland is energetically releasing new products, even announcing a group of network players in the “Select DSM Edition” series to replace Accurate. Mr. Gillard Tiefenbrunn, who leads Linn, is the Export Sales Manager.

He visited Japan for the first time in about three years, accompanied by Mr. Steve Croft of visited. The talk will focus on recent products.

“Climax DSM 3”
uses organic DAC
based on original design

---First of all, please tell us about the Climax DSM/3, the highest quality network network, released in 2021. of this product Japanese audiophiles were simply surprised by its appearance.

Gillard Tiefenbrunn (hereinafter referred to as Tiefenbrunn) During the coronavirus pandemic, Lin's staff were also forced to stay at home.

I felt depressed, unable to share the joy of listening to music with others or return to work in product development. So when the stay-at-home order was lifted and Naka was able to return to work, I wanted her to work on the most rewarding work. The development of Climax DSM/3 began with this idea, and it became a major project in which all staff worked together as one.

---That was the motivation behind your decision to make a full model change. Tiefenbrunn: That's right. However, the prototype of the original design discrete DAC "ORGANIK", which can be said to be the heart of Climax DSM/3, is



Lin representative Gillard Tiefenbrunn

Almost completed before the demic occurs I was looking forward to it. The KATALYST DAC architecture installed in the previous generation → Climax DSM/2 uses Asahi Kasei Electronics' A KM4497EQ as a DAC chip, and the successor DSM/3 also uses Asahi Kasei, F SS, or TI products. A new DAC chip such as the DAC chip was supposed to be a candidate. However, when we started selecting a DAC chip, we did not see as much improvement as we had hoped, and our desire for an original discrete DAC that would embody our ideals grew. When I started working on it, I realized that the sound of the organic DAC, the first made by Hakusha, was much more natural than the sound of the DAC chip, and gave a sense of human potential. At that point, it was still an early prototype and there was a lot of room for improvement, so if things continued as they were, it might turn out to be the best DAC. It was from this idea that we came up with the Organic DAC, Climax DSM/3 maximizes its performance



Lin Klimax DSM/3

The cabinet (chassis) and other parts have all been newly designed to maximize performance. --The proportions of the Climax DSM/3 are similar to those of the Climax DSM/3, which was the highest-end CD player. D12", but that's what I was aiming for. Is it something?



Mr. Gillard Tiefenbrunn

it would be best to base it on the same design and proportions as the Climax Control series. At the time, we also believed that it was important to reduce the number of operations required on the main unit as much as possible in order to highlight the features of the product. However, approximately 15 years have passed since then, and it is no longer possible for audio to work with networks. It has become so common that streamers no longer

Tiefen
 Brun Yes
 Well, that was one of the concepts. In 2007, the streamer (network player) Climax DS was announced. At that time, everyone Not yet for genre of knowledge with dio products I recognize that there is to receive In, Prian
 We decided that

It is no longer a new source device. It can be considered that it has matured and formed a genre. Having come this far, we wanted to make the Climax DS M/3 something that would give people a sense of joy and surprise when operating it. It's not a Lin product that has a lot of buttons on the front panel. I like something that is simple and intuitive to operate, like the CD12. --I see, it's definitely Climax DSM. The /3 has outstanding operability as a network player, and the visual and operational effects are excellent, making users feel like they're about to listen to music. It's easy to understand what you're thinking. The Select DSM series, which has a similar operation feel, also has that spirit.

Tiefenbrunn Thank you. These are very happy words. Most of the operations on the DSM series can be performed using an app, and we have received high praise for its operability. However, on the other hand, these are just audio products. As a product for listening to music, we wanted it to have an elegant presence and feel of operation. Of course, that feeling is reflected in all of Rin's products. The same is true for cts.



Mr. Steve Croft

"Select DSM Edition Hub" allows you to select various modules according to your application.

This feeling is certainly felt in

DSM H

in the DSM series. For our readers who are hearing about this series for the first time, please give us an overview.

The Steve Croft (hereinafter referred to as Croft) Scent DSM Edition is not a single component, but rather an upgradeable series like the LP12. Various modules are incorporated into the base model, which serves as a platform called the Select DSM Edition Hub (SELEKT DSM: Edition Hub), to expand its functionality. For example, for DAC, choose a high-end mono or stereo module equipped with optical organics, as well as Catalyst DAC or Standard DAC. You can also use line output, power



Selekt DSM: Edition Hub

As the model number indicates, the Koiso is a hub, which is the main body that stores the various modules prepared for the Selekt series and functions as components. Three new types of Selekt DSM modules have been added: Mono Organik DAC Module, Stereo Organik DAC Module, and Mono Line Output Module. The existing modules can be used as is in the new Selekt DSM: Edition Hub.

Mono line output module	
Mono Line Output Module	¥320,000
stereo organic DAC	
Stereo Organik DAC Module	¥700,000
monaural organic DAC	
Mono Organik DAC Module	¥1,200,000
System hub	
Selekt DSM: Edition Hub	¥1,600,000
Selekt DSM: Edition Hub package with Organik DAC module and output module	
Network player + preamp	
Selekt DSM-EO	¥2,300,000
Configuration: Selekt DSM: Edition Hub,	
Stereo Organik DAC Module, Line Output Module	
Network player + integrated amplifier	
Selekt DSM-EOA	¥2,400,000
Configuration: Selekt DSM: Edition Hub,	
Stereo Organik DAC Module, Poweramp Output Module	
Network player + preamp	
Selekt DSM-EMO	¥2,800,000
Information: Selekt DSM: Edition Hub,	
Mono Organik DAC Module, Mono Line Output Module	

Amplifier output, surround processing
Select DSM series so far? –

--What modules are available in the
Does it grow?!

Lynn has selected Select DSM as one
think it's a big concept. This time, Secret

which replaces the conventional
and the Harekt DSM edition,
positioned as part of the
Select DSM Ikiás lineup,

The Select DSM is

Classic (SELEKT DSM).

Sen, has been renamed to

Users can choose according to their usage.

scope of what can be done will be greatly expanded.

That's right. The

parts in-house using a facility system unique

We manufacture

to Rin. Develop unique products

--During the coronavirus pandemic, many

struggling to manufacture and procure parts
DSM Edition Hub is a 4-car manufacturer

as the use of a raised cabinet, but the Select
walled aluminum Kazurigawa Repunto, such

specifications are as strong as ever. This is a thick-

we able to create products like this?The

Is it? Why are

Audiome Tiefenbrunn During this pandemic

cutting machines that were originally planned to be installed in-house.

cutting at Hakusha to four, and also increased the number of metal

plan, we increased the number of 5-axis CNC machines for internal
during a pandemic. Regarding other parts in the capital investment

for a long time, but we have put in place a system that can be used

This served as an opportunity to accelerate that plan. Both have existed

— The concept of Select DSM is

business, we can call it "bespoke" at loki.
However, if we put this into practice as a

but I think it's extremely difficult to do so.

word. Tiefenbrunn: It's very difficult,

the uniqueness of Lin in every sense of the

everything in-house, and I wanted to pursue

As a streamer, I wanted to complete

looking at the chip, chassis, and software.

from different manufacturers, just

It has become commonplace to use DACs
from.

--Finally, a message to our Japanese readers.

Please give me a ji. Lin will be founded in 2023.

is celebrating its 50th anniversary, something big is expected.

that there would be some movement, but since the company

items. Fans were hoping

Tiefenbrunn: Right now, I think there are a lot of select

edition celebrating our 50th anniversary.

Feel the evolution of Rin with the DSM

next year, I hope you will look forward to it.

Let's just say that (lol). As for

*Product introduction of Selekt DSM: Edition Hub will be posted below.

2022 Tokyo International

Audio Show Report Hiroshi Miyashita October

28th (Friday) to 30th (Sunday), 2022 "Tokyo International Forum" in Yurakucho, Tokyo

The 2022 Tokyo International Audio Show was held for three days from October 28th to 30th at the Tokyo International Forum (Chiyoda-ku, Tokyo). As with last year, which was the first in-person event in two years, admission was required by advance reservation, but as social life has become more normal and booth hopping wearing masks has become a common sight, the venue will be the same as last year. It was filled with even more enthusiasm.

Sponsored by Japan International O

The Dio Council pays attention to infection prevention measures. Avoid so-called crowds and control the flow of people I was very careful about what to do. With Corona We have accumulated a certain amount of know-how by holding the event for the second time, and we would like to express our gratitude to all those involved for their efforts in making the venue run smoothly. Registration via the website reservation form An upper limit was set for recording. According to the council, the number of people was limited to about 1,000 on the first day, Friday, and about 2,000 on each of the two days of the weekend, but compared to last year, the number of people was limited to about 1-2000.

20% was eased. Applications quickly reached the upper limit, making it impossible to make reservations before the event began. Special consideration was given to visitors who came to the venue without being able to register because they were not familiar with using a PC. The attendance rate for those who made reservations reached exceeding the council's expectations. 3 days The total number of visitors was approximately 4,500.

Chairman Masaomi Suzuki (President of Accuphase) of the association said, "Those who go to the trouble of making reservations in advance are eager to come to the venue. Many people listened intently, and we felt a great response." "The QR code check-in process at the time of admission was also smoother than I expected." The distribution of numbered tickets for lectures at each booth has become a regular practice, and the venue is no longer so crowded as before that there was no room for people to stand. It seems that a behavior pattern suited to the era of coronavirus has become widespread: sitting in an orderly manner and listening carefully to the model of interest. At the popular Foons, there are always seats.





Dali Kore
(Importer: D&M Holdings)



B&W 703S3
(Importer: D&M Holdings)



Air Pulse SM200 (reference exhibit)
(Importer: Yukim)



JBL L100 Classic Gloss
Black Edition (reference exhibit)
(Import source: Harman International)



Yam 15 (left photo), 514EH (right photo)
(imported by Imai Shoji)



Yamaha NS2000A



Viega Coax 611
(Importer: Furen Coordination)



YG Acoustics Cairn
(Importer: ACCA)

filling up, while before the coronavirus, the building was closed, as openings starting to open at more convenient times, is still number of people that used to be at the building's peak, such this time. There was also a change here. The There are 33 trading companies/manufacturers exhibiting

The new participants are Ligere, which handles SMEs; Ukraine have led to the return of Axis, Furen Coordination, and Lin Japan, which had been postponed last time. yen, soaring prices of materials, and the situation in Despite the impact of the 2011 pandemic, the weak

foreigners visiting Japan and for the exhibition period, for the demonstrations stood out. It will be easier for the new model that was used as the playback source CDs, there were many booths that used analog LPs, and This confirmed its growing popularity. Instead of using

are also often seen, and digital files are Ana is rather rare. John Williams' fingers appears on both logs and digital discs, source. Like Star Wars, which frequently There was also a sound

Digital audio related



SACD CD player
Playback Designs MPS6
(Importer: Naspec)



SACD/CD player Esoteric
K05XD
(reference exhibit)



SACD/CD player
Audio Flight FLS20
(reference item)
(Import source: Ilex)



D/A converter, clock, headphone amplifier
dCS Lina series
(Imported by Le Taiyo International)



D/A converter CH
Precision C1.2 (Import
source: Zephan)



SACD CD player
TAD
TAD-D700



network transport
luxman
NT07(Reference)



Network player + integrated amplifier Rin
Selekt DSM EOA
(Import source: Rin Japan)



North D/D Converter
MSB Technology Select
Digital Director (Reference Exhibit)
(Importer: Axis)

Fun surprises from Esoteric and Luxman

In terms of product categories, sales were booming for power amplifiers, speakers, and analog players. There were more "shidama" that suddenly appeared at the show than usual, making it a fun sub-show.

Among the brands, Japan's Esoteric and Luxman grabbed attention for their "hidden gems."

On the first day, Esoteric launched the Grandioso series all-in-one prix "C1X Solo" and stereo

They announced the power amplifier "S1X" and the regular line SACD player "K05XD," showing their energetic side. Luxman surprised everyone by announcing their top-of-the-line integrated amplifier "L 5092," as well as their flagship amplifier "C10X" and their first full-fledged network transport "NT07" at the venue. Both are strong brands Reliable and reliable.

Power amplifiers are becoming popular with large machines.

The time has come for large aircraft to flourish, is a power amplifier. The Bulgarian Trucks "Spar Takas 300" that was unveiled as a reference exhibit is, as its name suggests, a tube-type monoblock equipped with six 300 B cells, and has an output of 50W (Pure A class). Together with the paired Libra preamplifier, which comes in two cases, it caught the eye with its sharp design. Greece's Pyrium also appeared with its large separate aircraft, Alexander (Pri) and Hercules (Power 1). Magico's ability to drive super-large speakers became popular.

Burmester introduced the stereo models "216" and "218," which were descended from the top model "159." The older brother, the latter, is for reference and exhibition only. I didn't expect that Kalline, the master who poured out the essence of the flagship, would show up so soon. Mark Levinson's ML5 model celebrates the 50th anniversary of the brand's founding.

Preamplifier



Esoteric
Grandioso C1X solo (reference exhibit)



Code
Ultima Pre3 (reference item)
(Import source: Time Lord)



Airtight
ATC-7

Power Amplifier



Mark Levinson ML50
(Importer: Harman International)



Accuphase A300



Burmester 218 (reference exhibit) (Import source: Noah)



Soul Note M3 (2 units in G)



Phasemation MA5000 (reference exhibit)



Trucks Spartacus 300 (reference exhibit)
(Import source: Stella)

also attracted attention. At the booth, JB sound. To bring out detailed good damping from 00 DD670 L model with Was: Everest domestic manufacturers as well. Accuphase Creation New products are eyeing company's 50th anniversary model. "A300" is a true example of the "M3" power amplifier. The popular the Soul Note, which featured the designer's completeness of the new power amplifier at work came together to show off the booked. Mr. Hideki Fujii's own line of MA5000 machine, was always fully which also featured the highly anticipated The large-scale Phasemation demo. Such reference exhibit.

Integrated Amplifier



Triode Evolution
300 30th
Anniversary (reference exhibit)



Luxman
L509Z



Hi-Fi Rose RA180
(reference exhibit)
(Import source: Triode)

Analog audio related



Analog player Rin
Selekt LP12 SE (Import
source: Rin Japan)



Analog player EMT
EMT928 (reference exhibit)
(Import source: Electric)



Phono Cartridge
Ortofon MC Diamond
(Imported by Ortofon Japan)



Analog player SME
Model 60
(Importer: Ligere)



Phono equalizer
amplifier Audio Specials Phonolab
1.5 (Importer: Ilex)



tone arm
Ortofon AS212R (photo left), AS309R
(photo) (both reference exhibits)
(Import source: Ortofon Japan)

appeared, including speakers and analog related devices.
Featured models have
"CA speaker", the new YG Acoustic
Sykes to the small woodgrain model
delivered in time, and from the resonant
Yamaha's latest model "N IFRN" was
be released in the spring of 2023.
However, the S2000A is scheduled to

I could hear it. Dai's first large luxury machine in a long time "KOR"
"Fine Vintage" series.
Also note the
center of attention.
It was the
field, it has been a long time since a large-scale SME
Series V, boasted an impressive E tone arm. In the analog
The V Player Model 60, an improved version of the
One of the hot topics is that it is equipped with "A."

likely to become a hot topic as a network
unveiled for the first time at the show, and is
Scision's new D/A converter "C" was
1.2" was also exhibited.
these attractive products are brought together in one place.
be able to see and listen to the actual product in such a way that all
that can only be achieved by holding an AI show. It's great to
It is recognized that it is a valuable event. There are benefits
I understood.

machine. "928" is a nod to the old name,
as the battery-powered belt-driver
The MT, which has the same number
It's an Eve machine.
Even in the digital field
An interesting product is born
flagship machine, TAD
the digital field, TAD's
D700" appeared. In
the "Playback Digital
commercial version of
the Zains "MPS6", and a
end head was called
SACD player with a high-
systems" attracted interest. An
phone playback
dCS's new series of "LI
It's called Inn, and it's a new attempt
and integrated amplifier).
DSM EOA" (various options
player with CH playback "Select

avant garde

AVANT GARDE

Trio G3 has everything except the mid-range and low-range horns. **Everything is new, and linear phasing between each unit contributes to improved performance.**

Mr. Jerome Andre



Jerome Andre

I think it is lent to. If you take a close look at sickle

products, you will be amazed at the high precision with which every detail is finished. How is production carried out? Andre

The design is completely a Vangarde independently owns its own. This is done by a technician, Driver unit and hose

The manufacturing of products such as containers is outsourced to an external specialized company. Avantgarde's headquarters are located in the Odenwald region, which is close to Frankfurt, and there is a highly technological production network around Frankfurt, which allows us to manufacture with the high precision we require. For example, horns are produced with micron precision by outsourcing to a specialized company that manufactures carbon frames for automobiles. Manufacturing the human-shaped horn requires a 2,500-ton extrusion molding machine, which requires two workers.

The mold is owned by Avantgarde.

That's what I'm doing.

How to paint the rental

horn? Andre: Painting the horn also requires a great deal of skill. For this reason, we outsource

the work to a company that specializes in painting prototype automobiles. They are a company that has the technology to fully meet our requirements, and they have a painting machine that can control 7 axes, so they are able to finish even technically difficult areas, such as the inside of the throat, with great results. There are seven layers of paint, and it takes more than three weeks in total to dry, so a large painting/drying booth that can accommodate a large horn is required, so it's probably not a job that paint factories would welcome. As a French person, I find German craftsmanship to be excellent. Our rigorous approach to quality is deeply rooted in our company, which allows us to produce avant-garde, high-quality products.

I was just told by someone from Esoteric that there was no appearance defect at all during the incoming inspection, which means that not only their ultra-expensive machines, but all of their products are manufactured to a high quality. It may be said that it is an important product that shows the essence of German industrial products. Thank you for today.

Last year, Germany's Avantgarde Acoustic, which celebrated its 30th anniversary in business, released the ultra-large 4-way all-horn system "Trio G3+ Space Horn," which was exhibited at this year's Tokyo International Audio Show and was recognized by the importer (Esoteric's booth was filled with enthusiastic audiophiles every day, but there was a Frenchman watching quietly. Mr. Jerome Andre is in charge of international sales at the company. We asked him about the ultra-large system and production process.

The other day, I listened to the Trio G3+ Space Horn in the crowded listening room at Import Gen, and was able to confirm that the quality had greatly improved compared to the previous XD version. The first thing I would like to ask you is the reason for the improved sound quality. What affects the sound quality the most?

In 1991, when Andre Avantgarde was founded, the all-horn type

Introducing the first stem model | Trio. After that, it evolved into the Trio G2|Trio In this model change, everything is new except for the small castle and the low range horn. You could say it's a completely new product. All driver units have been newly designed, and the acoustic center of each unit has been aligned to create a linear phase, resulting in improved performance.

dali

DALI

KORE is the highest grade machine.
 Developed with a strong focus
 on being made in Denmark.

Mr. Lars Walle



Denmark's leading speaker manufacturer DAL announced its flagship KORE at High End 2022 in Munich, Germany. CEO Lars Walle, who introduced KORE at the show venue, is coming to Japan for the Tokyo International Audio Show 2022. We asked them to tell us about their thoughts on KORE.

Miura: KORE, which was unveiled for the first time at the Munich show, became a big topic of conversation. Dali's booth had several component parts on display, such as driver units, and all of them were very serious and involved a lot of material.

Walle KORE was launched in 2008.

The original form can be said to be the Eminent ME9, which was designed as a design concept. A prototype that produced sound was completed in 2011, but commercialization was postponed due to the global economic stagnation. However, KORT brings together all the technologies for high sound quality that have been acquired since then.

This is a flagship machine that was completed from scratch (blank slate).

Miura: What did you pay special attention to during development?

Walle: Of course we wanted the technology and performance, but we were also very particular about making it in Denmark. As globalization progresses, a worldwide division of labor has become the norm, but the aftermath of the novel coronavirus has exposed its fragility. So KOR

In E, it is installed
 Worre driver was
 manufactured in-house
 as much as possible,
 and important parts
 such as the enclosure
 were also sourced
 from Denmark.

Miura: Around
 the time the Epicon
 series, which is still
 very popular today, was
 released, I went to
 Denmark and visited Dali's factory. epicon
 The midrange and woofer were
 manufactured in-house for the
 first time. Walle: That's right. Epicon?
 Since then, we have been able to produce
 driver units in-house and have accumulated
 manufacturing know-how, which has been
 very helpful to people. For example, the
 powerful balanced drive SMC midrange and
 woofer in KORE were designed and manufactured
 in-house at Dali. In Dali, mid-range

Compatible with large neodymium magnets
 We also introduced a magnetizing
 machine. KORE uses die-cast aluminum
 baffles and resin composite pedestals, which
 are sourced from easily accessible
 domestic suppliers. We also acquired KORE's
 laminated plywood enclosures by investing
 in companies that manufacture
 high-end furniture. Miura: According to the
 technical data, Dali's SMC (soft magnetic
 compound), which reduces distortion
 components in the magnetic circuit,
 has also been improved. Walle's
 in-house research and development team
 We are always looking for improvements and new technologies.
 Miura: I would like to ask you a final question.
 At KORE, the distance from the listener is 3 meters.
 It says that it is set to the default setting. The reason
 Could you tell me about the mountain?
 Walle: When considering the diameter
 and position of each driver unit, a
 distance of 3 meters became one of the
 guiding principles. From there, the size
 and volume of the enclosure were
 determined and the KORE floor standing
 machine was created. Miura: I hope
 that the high-quality sound technology
 obtained with KORE will be used in
 other products. Thank you for today
 I was there.

Lumin

LUMIN

At the Tokyo International Audio Show venue, I was able to meet three of the core members of Lumin who came to Japan from Hong Kong. They are Mr. Nelson Chey, President, Mr. Lee Ong, Development Manager, and Mr. Angus Leung, International Sales and Marketing Manager. The purpose of coming to Japan was to see the show and have meetings with Japanese manufacturers. They seem to be providing network-related technical support not only to Japan but also to many audio manufacturers. First, I asked him about Lumin's history.

Chey was founded in 2003. Initially, we were developing a video processor that up-converted 480P video, which was booming at the time, to 1080P, rather than audio equipment. The product was intended to be used in conjunction with high-end projectors, but after this movement died down, we launched the Lumin brand in 2012. From now on, the world of high-end audio



This is because we believe that the shift to digital file playback will create a huge opportunity. At the same time, I thought that high-quality audio streaming services would eventually become popular. On Lin and others who were ahead there Research network players and

To meet user demands
We have carefully observed the market and refined our technology.

Mr. Angus Leon
• **Mr. Nelson Chey**
Mr Lee Ong

Achieves functions and sound quality that are second to none.

The AL player was created with the idea of developing a product that would do just that. At the time, Rin made it compatible with DSD file playback, which was compatible with dogs, and later on, we added a decoding function for MQA A, which was adopted by the high-quality streaming service TIDAL, in order to meet the demands of all

users. We have carefully observed this and refined our techniques. Furthermore, since its inception, we have improved the ease of use of the popular "Roomin" app, including support for tiled display that allows full-page display of album jackets and faster access. did.

Leon This time, I played the Lumin amp.

In addition to inner-up, you can now promote Lumin sound with a total solution. It is also a lifestyle proposal. We believe that a simple system can meet the needs of people who want to enjoy high-quality music. This amplifier was completed in collaboration with Westminster Labs, the UK company of which I am the owner. I studied abroad in the UK and worked there for a long time, so collaboration with staff from both companies is very smooth. Yamamoto: Lastly, please tell us about the sound that Lumin is aiming for. Leon: Well, we're aiming to create a smooth, glossy sound that is comfortable to the ear. We chose a Lundahl transformer for the output, a linear power supply circuit, and a lead processing volume for the volume control section, all in order to achieve the sound quality we were aiming for. I think we will be able to announce new products by the end of this year. Please look forward to.

pyrium

— PIRIUM

**All products are like my children.
All parts are of the highest quality and reliable.
There are no cost limits at all**

Pyrium's amplifier is rapidly becoming well-known in the world of high-end audio, and arrived in Japan for the first time this year. Mr. Konstantinos Piliros, the organizer of the company from Greece, which is a member of the EU, came to Japan for the Tokyo International Audio Show 2022. We asked him about the company, which is still relatively unknown in Japan.

Miura: I heard about the brand Pyrium when I visited audio shows overseas, including in Munich, Germany. First of all, could you tell us about the origins of the company?
Piliros I am an audiophile born and raised in Greece. Pyrium was founded in 2014 by me, who has loved music for many years, in order to pursue the ideals of electronics and the ultimate in audio. The company name was an arrangement of my last name. Design and development began in 2012.
Miura Pyrium designer = designer

Mr. Konstantinos Piliros



Konstantin

How many people do you

currently have? Pyliros: I am in the general position of Dinkler, and there are currently three designers. Two of them are analog designers and one is a digital designer.

Miura Currently Divine

Nine products are introduced on the website, including D/A converter models, and the remaining eight models are amplifiers, including integrated models. I believe the previous lineup was called Brutale. Pyrium amplifiers are world-renowned.

Human-shaped electrolytic capacitor used We brought a double-sided through-hole board, and all the parts used were of the highest quality and reliability, and the sound quality was thoroughly examined.
There are no cost limitations

— INTERVIEWER

Miura: It's this big and well-built. Equipped with an electrolytic capacitor I have never seen the product. The Kawaji board is also hard and solid, with a thick copper pattern and gold plating. Each element in each unit is also rigorously selected, and the Teflon-coated internal wiring uses high-purity copper wire made in Japan. Dual mono configuration D called Electra /A converter with the world's highest performance Japanese AKM DAC that provides Four elements are used per channel. I'm running.

Miura: What kind of speaker system does Pyrium use within the company?

Piliros Maju's A5 and Lithuania I use Virtuoso M speakers by Audio Solutions of the Republic of Korea. I was able to hear directly from Miura and understand the characteristics of pyrium.

became famous in the world when American Magico installed a total of four Hercules monaural power amplifiers and Alexander preamps to play the M9 with its new listening rating. I think that was the trigger. Period, isn't it?

Ridge. When our American distributor introduced Pyrium's products to Magico's Aron Wolf, he liked the sound. I was one of the first visitors to hear the M9 sounding at that listening rate. Become a person.

Miura: Please tell us about the characteristics of

Pyrium's sound.

Piliros: I consider myself a person who strives for perfection. Pyrium is built on this spirit and without compromise, so all of our products are like my children. As you can see, the product

SS Interview Kenji Mayuzumi

SME
SME
SME

Following the engineering principles of Model 30, The Model 60 has achieved a major evolution through the use of cutting-edge technology, new materials, and craftsmanship.

Mr. Stuart McNeills



Now that we have acquired

This brings us to H.

I'm Briti

Sh Aero

Enter with space as a zinnia

I have been working for a year

However, Kade

up his current

position six years ago

at the request of

Chairman of the Board. I have always loved music and audio, but being involved in the development of audio products feels like a strange connection.

The Mayuzumi Model 30 has been SME's flagship for over 30 years, but what makes the Model 60 different from the Model 30? Is it? The

Model 60 follows the engineering roots of the McNeills Model 30, and has made major advances in computer-integrated design and the use of new materials. Utilizing our specialty, precision machining using cutting-edge computer control,

However, we were not able to achieve the level of perfection that we desired. In addition to audio, SME is also involved in the manufacture of precision parts for aerospace, medical equipment, and motorsports such as F1 machines. The Model 60 is made possible by the advanced skills of the craftsmen who support these products. We were able to make it happen.

Development began with a thorough analysis of the Model 30. As a result, we found that improvements were needed to the chassis, suspension, turntable drive system, tone arm, etc. At the same time, in order to absorb the minute resonances generated by the rotation of the platter, a damping bath filled with silicone oil is installed at the bottom of the bearing, and the AC motor is driven by a separate power source controlled by DSP, etc. Furthermore, the tone arm uses a high-density, high-rigidity polymer resin arm tube (triangular in cross-section) that has good acoustic properties, reducing mass and suppressing resonance, resulting in improved sound quality. Improved in width.

Mr. MacNeills must really like O'Days. Once I start talking, I can't stop. The story lasted for over three hours, and I've only been able to introduce you to the introduction. I hope to be able to report on the continuation.

Please tell us about the current situation of SMEs.

What is the company name of McNeills SME?

The company was founded by Alastair Robertson-Eickman (whose company people respectfully refer to him as "ARA"), who came to Scale Model Equipment. Initially, ARA was a manufacturer of precision scale models, but as an incomparable music lover and audio enthusiast, he began making tonearm prototypes as a hobby, and an acquaintance and friend who saw his work encouraged him to commercialize it. As a result, we built a new factory and began manufacturing. The first generation 30093012, created by original ideas and the hands of skilled craftsmen, has a high degree of perfection.

It quickly gained popularity and became

the top tone arm brand. After that,

tonearms such as Series II (2 years), Series

Improved (2 years), and Series III

(1977) were developed, and the Series V

was introduced in 2006. Furthermore,

in 2013, the company announced the

Model 30 turntable, establishing its position

as an audio manufacturer. In 2016,

70 years after our founding, we became

a subsidiary of the Cadence Audio Group

in order to make further progress, and

the British turntable manufacturer Galer

audio ontology

In search of lost sounds

- Existence and time,

Or Masaya

Chiba

audio and home

Born in Tochigi Prefecture in 1978. Philosopher, writer. Professor at Ritsumeikan University Graduate School of Frontier Sciences. In 2019, he won the 14th Noma Literature Newcomer Award for his first novel "Deadline," and in 2021, he won the 45th Yasunari Kawabata Literary Award for "Magic Mirror." His recent works include "Introduction to Modern Thought" (16 Kodansha Gendai Shinsho). "Deadline" was published in paperback at the end of August (Shincho Bunko).



Audio is about facing the existence of sound. That's true. And "reproduction" means reviving sounds that existed in the past, so audio is nothing but a confrontation with time itself. existence and time.

That is the title of Heidegger's master. Listen to the past. Recordings are traces of the past. So Not only that, but the audio hobby itself is becoming more and more popular. has a tinge of the past, the 20th century.

The way audio is used in daily life has changed. As the world moves toward owning fewer large items, even the size of a mini-component may be an exaggeration. Only some hobbyists pursue sound quality. I wonder how many people are looking forward to audio that involves people these days. On a similar note, it has become rare for people to want to own a car that is beyond the scope of practical use.

Broadly speaking, the times have moved in the direction of "dematerialization." I'm trying to let go of my personal baggage. Not only that, but there is also a shift away from materiality itself.

By the way, the sound on the MacBook Pro I'm currently typing this on is quite good. 14!

I bought a new model because I bought a new one, but it now has a wider range of uses and a clearer stereo image. It's frustrating to think that this is not the case, but Apple, which also offers music streaming, is thinking about what the modern audio experience should be.

I put down my audio equipment once in my early teens.

After releasing it, you will get used to the sound of the compressed sound source and will be able to understand how much the CD is

I forgot what the sound quality was. It was also burned when records were changed to CDs, but in the 21st century, the sound experience of data that sacrifices sound quality is an incredible degeneration. However, that too has been improved. After reviving Western Electric's system last year, I compared streaming from each company, and the lossless or high-resolution sound sources are certainly different. Listening to these differences was, for me, the first step in rehabilitating my audio sensitivity. What's the difference. What I see in the air around the main sound seems to be different. Like a blurred pattern, you can see something that conveys the movement of the past. It's good to compare. This can be said to mean that the sound has a presence. Dew.

We have come to treat music as data. Rather than listening to store music that has been "individualized" into discrete units such as discs and tapes,

Search a seemingly endless database. Is it really paradise that we can now listen to music from all over the world at any time via streaming? Once upon a time, music had more materiality. Listening to music was a material way to confront time.

Now, in the context of talking about "existence and time" in audio, it may seem a little strange, but I would like to think about quitting audio and letting go of the audio set.

I inherited my audio hobby from my father. However, my father has now stopped using audio. At home, which is interesting in its own way, I play background music on my fortune-telling CD component. When I return home, the same CDs are always playing in the space. This gives me a sense of security, and I have an indescribable feeling that the act of listening to music itself stops time at a certain point.

When I was in high school, my father and I went to an audio store in Akihabara.

I once went there and listened to a speaker with a unique flat unit. From what I remember, it's probably an Infinity speaker. I also remember the teardrop-shaped cell-frame glasses the store clerk wore at that time. He treated the two of us who were not likely to buy it anyway, looking like it was a bit of a hassle.

audio ontology

It's wonderful, but you can't make such a human sound in an apartment. Even though I didn't introduce myself, I decided on the listening environment, and at first I made a human sound, but then... So I turned down the volume. He showed us the "reality" by saying that this is how things usually happen. We didn't know where his judgment came from, but in general, audio exists in a painful conflict with reality.

At that moment, I became strangely aware of this. In a previous article, I focused on the fact that Okihiko Kanno did not consider audio in its ideal state, but instead focused on the balance in each individual environment. However, there are always "realistic problems" in audio. That's why. And ultimately, the reality may be that it becomes impossible to maintain audio.



Masaya Chiba

deadline

DEADLINE
MASAYA CHIRA

Shincho Bunko

I wrote a little about this situation in the first part of the series, but I was unable to write my master's thesis during the two years of

my master's program at the school, and I managed to do something with three holidays, but I failed, and on the same day that I failed, my father's company went bankrupt, and my family was jointly bankrupt. Ta. I wrote a novel called "Deadline" in 2019 based on this background. The novel traces his move to a smaller room, and his father's entrustment of his clothes. There is a scenario in which people simply load up Stan Electric's audio and take it to their hometown.

At that time, I turned down the audio. I returned the Western Electric speakers and amplifier to my father. Some of the parts are life - It may have been sold for money. father then ended up getting a new job

However, from then on, I no longer had time to listen to audio loud as I used to in my life at home.

The impetus for this series was when I downloaded Sakuge Audio.

It was a song. Why did you restart the audio?

It was to suture the wound of letting go of audio in my 12th year as an apprentice. I was trying to "replay" my old world, the world just before that point, through audio.

This is a very personal story and I'm sorry, but

Thus, having an audio set requires a space, and this is achieved through a series of

coincidences in life, and at some point, that condition may suddenly come to an

end. . Because high-end audio is high-end,

It is natural that it becomes a symbol of an inn, but there is an implicit assumption that it is real estate.

Listening Room features often implicitly boast about

mansions. In this

series, audio refers to the existence of sound itself.

It started with the thesis that the best way to listen to music is to listen to music, and has gradually expanded the topic.

Gradually, looking back on the era of audio has become an important topic.

Looking for a home, going to the city, smoking cigarettes, going big.

Amidst the post-war, Showa era scenery of drinking alcohol,

there was also excellent audio. Entering the 21st century,

Things became more and more fluid, and people stopped clinging to fixed things and stopped focusing on

sustainability. Life began to resemble a collection of momentary fragments. The same may be true of a person's identity.

A way of life that pursues efficiency, using multiple faces as appropriate on the spot, and avoiding wasting

unnecessary baggage, has become commonplace. The mindset of holding on to dull pain and "sublimating" it to increase the depth of life has become more stale than it used to be.

I think so.

It evokes things that don't move, things that have always been there.

Streaming allows you to explore new music while also reacquainting yourself with discs you've listened to many times before.

Sometimes I remember intimate moments. When I was in the sixth grade of elementary school.

Before going to bed, I was listening to Larry Carlton's

<Alone/But Never Alone>, which I recorded on cassette from

D, on my Walkman. At a time when staying up late at night is still not acceptable, that album foreshadows an unknown time

that unfolds in the darkness, but before we can step into that, there is a moment when the curtain of drowsiness falls. It was

BGM. You can use it on your iPhone anytime, anywhere.

audio

ontology



You can also listen to *The feeling of that night*

is now far away. Still, it hasn't disappeared.

It's faint, but it's still there. Play sound.

Summoning the presence of sound once

again like a ghost. Welcoming spirits like Obon
put in.

I am trying to evoke memories of the days when people were
obsessed with carrying large amounts of luggage. In other words,
to discuss audio now is to question the quality of ordinary wood,
and at the same time to consider the "imagination that revolves around

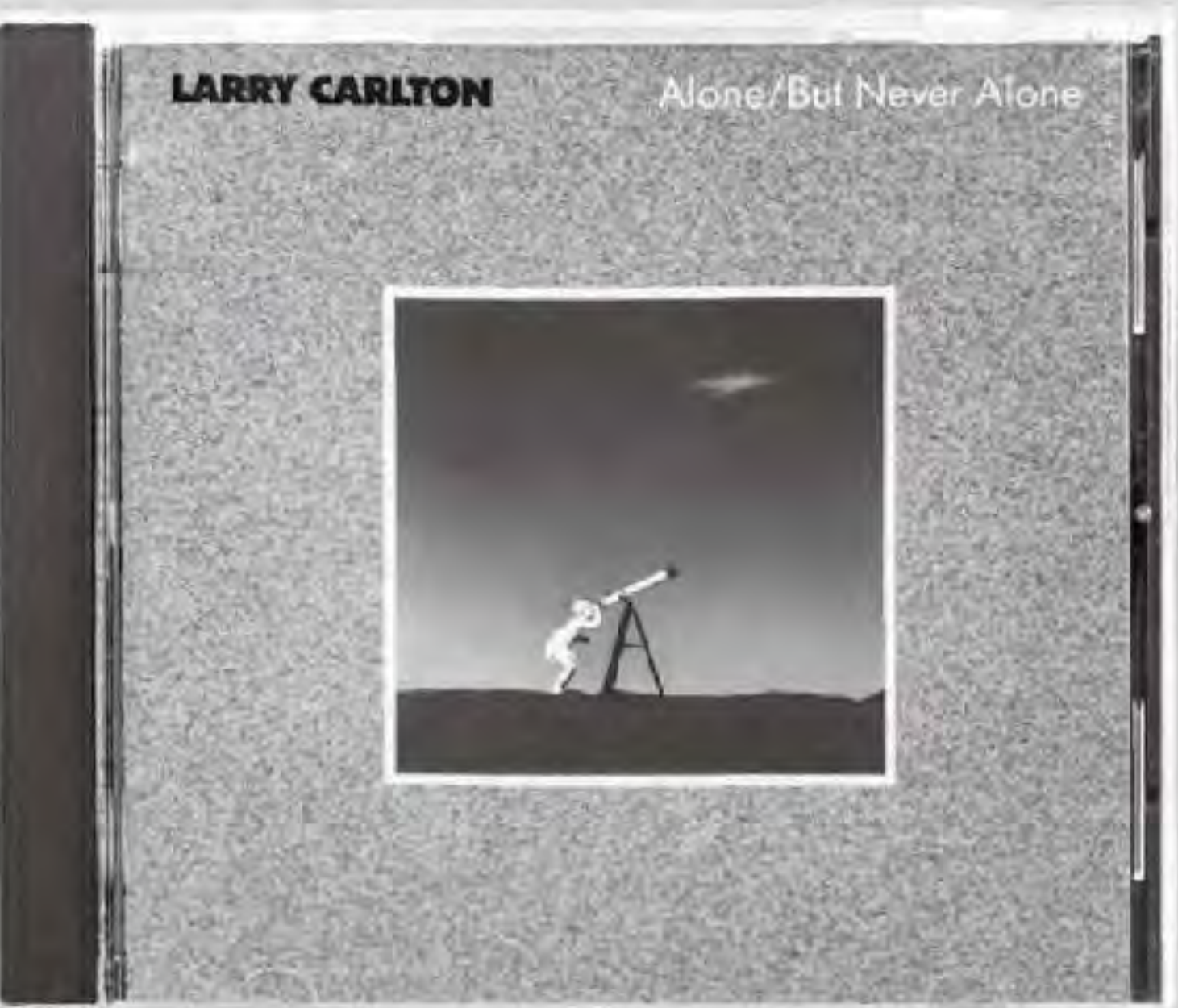

certain immovable things."

connected to things
ing.
just a house

I don't want to
say that the era I
tried to live in was
a good one. However,
this may have
something to
do with human
ontology, and this
may have changed.

Immutable things, real estate. In other words, it's a home. House,

Existence, time. This theme is Heideggerian. The physical finiteness
of a single disc made the musical experience highly

concentrated. Face one object for a long time in one enclosed
space. Such attitudes are becoming a thing of the past. I think
it's becoming more difficult to listen to albums these days. I
can't imagine listening to music that way through streaming.

It would be fine if we only had the convenience of
being able to instantly call up all kinds of music, but if that were
to become possible, a side effect would seem to be that we
would no longer be able to listen to music in a thoughtful
way. The way we create today's songs depends on whether
we can grab their attention within the first 10 seconds or so.
It is said that it has become.

Life is fluid. Change your job depending on the situation,
Even if we change our homes, share things instead of
owning them, and become split into two, even our
very beings drifting between things, what is there that
we still need to be able to do? An attitude toward
facing the sound itself. contains questions about such
dichotomy itself. In an age when we are becoming
dematerialized and becoming like ghosts, audio time is a time
when we can return to some other place as ghosts, a time
like Obon.

Continued near field listening

the pleasure

My cerebral infarction, which I wrote in the previous issue as "Chasing and writing"

First, let me tell you about how I crossed the Sanzu River during the vocatheter surgery. Unfortunately, the cherry blossoms fell before they bloomed, so I was only able to see them from the hospital window. The cherry blossoms that were blooming in the small park on the other side of the glass were dim and dazzling, and I have only a vague memory of them. Ever since I was a child, I have had a hard time shaking the question from my head: what happens to people when they die? Of course, as a child, I was very afraid of death, and I definitely wanted to die. It wasn't that bad. So, in case of an emergency, I thought about how to avoid death by any means possible.

I got it. Once upon a time, a movie actor named Tetsuro Tanba lived in the "spirit world"

I was writing a book about "Tetsuro Tanba."

There is a movie called "What Happens When You Die in the Great Spirit World?"

was made. Curious, I watched the movie.

However, when he collapsed and was taken to the operating room, it looks exactly like the world drawn by Tetsuro Tanba.

The "spirit world" has appeared. On both banks of the Sanzu River Beautiful flowers that are out of this world are in full bloom.

Then, when I was about to cross the Sanzu River, I suddenly remembered what I had been thinking as a child. The point is, when the ferry boat on which the boatman is rowing has docked on the other side, he must never get off the boat and go into the hellish waters that lie beyond the other side. My childish idea was that I wouldn't die unless I landed on the other side and went to the land of hell beyond that. When I was a kid, I rehearsed it over and over in my head. I did it.

♪ 26 26 ♪

This moment on the operating table in the hospital is the real practical experience. When the boat docked on the other shore, I saw a cave, and an old woman who appeared to be Amenuzume, wearing only a thin layer of clothing, came out dancing. Then, from inside the cave, I heard a loud voice calling out to me, saying, "Hey, Wakawa-kun! Come here, come here!" "What!" I looked up to see who the voice was, and it turned out to be Fumihiko Yoori, a member of the side. From behind it, no matter how you listen to it, you'll hear a 15-inch woofer and a compression driver for the mid-high range.

bone that seems to be

Thick JBL type

I could hear a lot of noise. Moreover, the land of quality, Hiromi Wada But Stevie Ray Vaughan's strike Ratcaster explodes in "Texas Flood"

Next up is "Stripped" by the Rolling Stones. An album was playing. Shin Hosoya was the one who almost always played these two cards on the test machine. It was later replaced by "Amnesiac" by Native Head. "Packt Like Sardines in a Crushed Tin

♪ 26 26 ♪

If you look closely, you can see that Mr. Hosoya is also beside Mr. Zenuma. Hmm, I'm really happy to see a rock-rock crowd, even in a human country. I was able to meet Mr. Asanuma and Mr. Hosoya, both of whom are still doing well in the afterlife. But it is. It would be no good to get off the boat here and go straight to the cave. "Don't go!" Simulation of the early days of production But apparently it helped. to the boatman on the other shore When I asked him to turn back and worship me, the ship

The head reluctantly agreed. Ichiwagawa-kun, come here!" Mr. Asanuma and Mr. Hosoya called out to me in a loud voice, waving to me, and I left the riverbank in the land of hell, feeling my hair dragged behind me.

When I woke up, I was lying restrained with belts on a hospital bed, suffering from severe pain from a foreign object (a thin tube?)

inserted into my urethral opening. It's scary not knowing how bad the pain and disability will be when the soul of Shirabun returns to the body, but in this way, I will return to this world again.

Came back. The time circle that flows on the ground has all sorts of rules, all sorts of conventions that tell you what to do, what happens when you press here, and all that, and I just feel cold.

Two months after being hospitalized, he returned home with a pitiful body that was just skin and bones, a level of "nursing care level 4" that seemed to be crushed by the earth's gravity. My doctor says that Mr. Ichiwada plays the bass. Think of it as rehabilitation and try practicing the bass." Well then,

Let's try playing it
try making a sound

But it moved quickly
stops.

I'm just sleepy

I feel tired. notice

And I'm a heavy bass

It was crushed under.

There were so many mountains like that that it was mind-boggling. I am now able to write this manuscript thanks to the editorial department of Stereo Sound and the many people who are still helping me, but I am too humble to express my gratitude

honestly. The Disney animation "Soulful World," which I briefly introduced in the previous issue, was the first movie I wanted to watch after returning home from "The Land of the Underworld,"

so I rewatched it on 4K UHD Blu-ray. is. Just like Joe, the jazz pianist from the other world who returned to his hometown, I was inspired to live my life with a new focus on Shun and Mercy. It makes me cry."

Hakubun was once again forced to think carefully about the meaning of audio, what the ultimate speaker system is, and what it means to love it. Listen to music and listen to sounds. Only now have I realized that this is why I was born into this world. often

I understood it very well. This is what I learned after suffering a cerebral infarction. If you listen to Fugaku and listen to the "sound," you shouldn't have any trouble at all. So, now that I am living again, I have renewed my resolve to tell fortunes, speak, and listen to them as a way of expressing my gratitude to my wife and friends.

The origin of my audio

I love rock, jazz, and audio more than anything else. In the previous issue of this series, I wrote about my love for speakers, but this time I would like to change my mind and go back to the origins of audio, and talk about "small audio," which has an endless charm even if it is modest.

"Small Audio" is a coined word that is a play on "Small Baseball." In the 1990s, Hideo Nomo made a big splash in the American Major League Baseball (MLB) by making full use of his forekballs that dropped with a "thud", and then sometime later, players named Akira Suzuki and Amelie

small audio

Continued near field listening

The

pleasure of O is interesting and enjoyable. Nirvana, Redemption Head, and Electric Miles are all so amazing that I sometimes find myself on the edge of my seat. It's definitely great when listening to classical or jazz. I'm sure you'll think, "I'm glad to be alive!" (in my case). Right now, I want to listen to music and good sounds until I die. A place where I can say "I'm glad to be alive! The food is delicious! Isn't it heaven (even though it's on earth)?"

Speaking of music, I've been listening to every album recommended by Beat Ink lately. It introduces many innovative and rich new releases from overseas. It's all dense, experimental music that appeals to my sensibilities. Everything is organic, resonates with your soul, and warms you up. Full of mystery. There are so many fantastic and borderless albums. Brian Eno seems to be involved, so maybe that's only natural. I learned about Alabama Shakes, Kamasi Washington, and Khruangbin, which I learned about from the super music connoisseur Peter Barakan, as well as Toronto, which was created by the mysterious recording engineer from the Philippines, Russell Elevard, instrumental Alba from the band Pad Pad Not Good

The representative lightweight speaker that should be used is Vivid Haudeno. The mid-sized models KAYA25 and KAYA45 are both designed with space factors in mind. KAYA means "Home" in Zulu. The strong glass fiber reinforced plastic sandwich construction of the cabinet makes the KAYA extremely lightweight, but the sound is clear with excellent dynamic range and clarity. Although these are old products, I would like to list a number of small speakers that I fell in love with. First, Goodman MAXIM, and then Technics 1. In the 1980s, when CDs were introduced, Harves LS3/5A, Harves HL-P3, After the Resion SL6 and SL700, the best small speaker for me was the ATC SCM10. All of the speakers mentioned above are really small, but they all produce authentic sound, and I can confirm that the sound is excellent. Don't forget the ALR Jordan Classic. All of them have an accurate stereo image, a vast sense of space including depth and height, and accurate and bouncy bass that makes it easy to understand the pitch. I would like to stress that anyone can obtain true high-end audio-like sound as long as they are set up properly. In other words, there are various

He played a remarkable role every day. Nomos's The powerful fork is definitely suitable for MLB. I thought that Ichiro's baseball was very detailed and ingenious, which is typical of a Japanese player, and he played baseball with the delicate and quickness of a small soldier. do not have. He used his feet and agility to play small baseball," running around the narrow field, and before he knew it, his batting average and small-base percentage were by far the best. Everyone knows this well. Baseball, after all, is all about winning in the end. It's a truly American men's sport, with bare-chested men hitting each other with their fingers crossed for victory. Recently, the sport of Shohei Otani, a truly smart and refreshing sport, is playing. Young people are active in this field, but when it comes to audio, it's quite difficult to create a perfect, well-balanced sound like Otani. Especially when it comes to humanoid speakers. Sound and music preferences It really varies from person to person, so it's best not to write too much about it. High-end speakers have become heavier and heavier over the past decade. But now it's over 100, no, over 200. There are a lot of speaker systems out there. Starting with aluminum machined enclosures Cabinets are becoming heavier and more durable year by year. However, a lightweight and luxurious product that goes against this trend. There is also a speaker system. Among them, pay attention

Beat Ink's WE

Site B is always worth checking.

BEATINK WEB site: beatink.com

purify the upper stream

In the next issue, I'll be visiting the listening room of a friend of mine who's a designer, guitar player, and cat lover, and I'll be introducing his small audio system to everyone. The speakers aren't expensive, but the sound is great and the cats are happy. In the recent white small audio

Talking about this, I would like to talk about my favorite YG Accouste.

The Tyx Haley 2.2 is a relatively small floor-standing sealed 3-way speaker. This is a small audio system with the Haley 2.2 at its core, and the specs and technology used are absolutely amazing. The current focus is on cleaning up the upstream. I have previously written in this series that the Beskanbe Ushigawa River, which flows into the Akkeshi Current in eastern Hokkaido, is a truly clear stream with no industrial or small-scale wastewater flowing into it. When it comes to delicious oysters from Akkeshi Bay, I think they are the best in the world. For the past 15 years or more, I've been ordering it every winter, and my audio friends have gathered together to enjoy it. I also want to clean up the upstream of the audio system. I worked on it first



VIVID AUDIO KAYA25

The goal is to introduce the "Zero Link System," which was jointly developed by Sforzato and Soulnote, into the network audio system. With this, the sound quality of high-resolution (and CD/SACD playback) has become dramatically more transparent. Furthermore, I connected Soul Note's 10M master clock generator X3 to the DAC section. This also worked hard. The sense of three-dimensionality, detail, and space are amazing. In terms of depth, I used to feel it was about 5 meters deep, but now I can feel it even deeper, about 10 meters. If the upper reaches are clean, oysters will be surprisingly delicious.

The same goes for sound and music. Next, this is also upstream in the sense of source equipment. I think I'll use the Valtere MGIPKG as an analog player, or the higher model SG1PKG. Hmm. Cleaning costs a lot of money. In the end, it always sounds good. First of all, work hard and save money. It's strange to live on earth, but as long as you're rewarded well later on, you don't care about that at all. Because it's for the sound and music I love. "Love is everything (The Beatles)."

Biography of Japanese Engineers

Listener Editorial Department

Composed by Takayoshi Ito

Mr. Shozo Inomata, Shinten Juroku

The Southern All Stars demo recording was my starting point as an engineer.

Locally produced rock/pop music as a business In 1976, when signs of success were starting to appear, Victor established a rock label, "Flying Dog," whose first artist was PANTA, who had just disbanded Brain Police. The person who took the lead in establishing the label was producer Ken Takagaki, who was still working in the Western music promotion department at the time. The following year, they launched the "Invitation" as a new band with a more humanistic development than Flying Dog, and Mr. Takagaki was preparing to make his debut with this invitation when he was a student at Aoyama Gakuin University. Southern All Stars is a six-member band led by Keisuke Kuwata.

"I believe it was January 1978, early in the new year.

Shozo Inomata is from Victor Studio and is the first member of Southern All Stars. Known as an engineer, Takashi, who appeared in the 7th installment of this series.

Mr. Hideo Ta was his direct superior during his time at Victor and was a Southern All-Star. The reason behind my decision to be in charge of the project was the advice of my mentor, Mr. Takada. It is said that there was. First, we talked about an episode with Southern.

I think it was about. Mr. Takaoka said, "Ino, "Can you record a demo for a new band?" I was asked. At that time, I was still an assistant and was learning how to record various genres such as popular songs, new music, and jazz/fusion under the guidance of a senior engineer. On the day I was approached by Mr. Takagaki, Mr. Takada was in charge of Sadistics Encoding, so I turned it down without really thinking about it, saying, "That's impossible." When I did that, Mr. Takagawa, who was always calm, scolded me in a very sharp way. "Recording a band's demo is the engineer's gateway to success. You should absolutely do it." Without that advice, I wouldn't have the career I have today. I think so."

Some of the songs recorded during this session include the songs that were later released on the first album "Hot Chest Sawagi" (2016).

The song includes songs such as "Farewell for the End", "Call a Woman Boogie", "Turn Your Back on Chigasaki" and "Imatake Anata ni", and Mr. Inomata was impressed by the wide range of the songs. He said he felt Keisuke's extraordinariness and depth as a songwriter.

"If I had only listened to the comic-style "Call Me a Girl, Boogie," I might have thought that this was just a band made up of college students. However, Kuwagawa-kun was the kind of person who could sing a beautiful melody like "Farewell is the last thing" and the band was able to build an ensemble like "Turn your back on Chigasaki", so I can't put it into words. I felt a sense of possibility, or rather, hope. Thanks to the success of this session, I was also in charge of the actual performance, and their debut single "Katsushita" was released.

"Sinbad" ended up being my engineer. This is my debut work. So 202 of rice cultivation



Shozo Inomata
Shozo Inomata

Born in Tokyo in 1953. After graduating from high school, he entered a design school; but after visiting a recording studio as part of his class, he developed an interest in music production, and after a year of apprenticeship at a music production company in Tokyo. Joined Victor Studio in 1975. In addition to Southern All Stars, she is in charge of Junko Sakurada, Mako Ishino, A.R.B., etc. After reciprocating Victor in 1981, he worked as a freelancer on works by Miyuki Nakajima, Yoshio Harada, Koji Sera, Masahiro Kuwana, Kenichi Hagiwara, Yusaku Matsuda, and others. In recent years, he has been working on recording mixes in a wide range of genres, including for artists such as BoA, Keiko Masuda, Peter, and Coralfree, as well as soundtracks for TV programs and commercial music.

3 is the 15th anniversary of Southern's debut, and at the same time it's also the 45th anniversary of my career as an engineer." My experience at Victor Studio became the foundation of my career as an engineer.

The collaboration between Mr. Inomata and the Southern All Stars continued until August 1981, when Mr. Inomata went freelance, and the albums included "Hot Chest Sawagi" as well as "10 Numbers Karatto" (2017) and "Tiny Bubbles." (1980), "Stereo Taiyozōku" (1980), and four singles remain, including "Chaco Coast Story". Since then, Victor's house engineers have been in charge of engineering successive generations of Southern's works, but there are only six former members, including Mr. Inomata. If Southern is a group that boasts a long career and track record, it would not be surprising to hear that they would be recording overseas or hiring foreign engineers, but even now, as they approach their 15th anniversary, they are still in Victor. However, while using Victor's 101 Studio as their base, they continue to rely heavily on Victor's house engineer.

"This is a rare example. Of course, I think it's because Victor and his agency Amuse are always creating a system that makes it easy for Kuwagawa to work, but anyway, Kuwagawa loves studio work so much that it's amazing. When it comes to recording, I don't want to carelessly change the location or seating arrangements that are easy for me to perform. History

Each generation of engineers worked together in real time. Although we weren't working together, we all got along really well and regularly held drinking parties called the "Southern Engineers' Meeting." There are six members: Masahiko Ikemura, Kunihiko Imai, Tenichi Hayashi, Kei Nakayama, Koji Hiranuma, and myself (Mr. Hiranuma passed away at a young age in 2020). There were times when Kuwayama-kun and Takagaki-san washed their faces. When I listen to the sound I recorded now, it seems young and a little rough, which is embarrassing, but talking to them brings back a lot of memories. The rhythm for my first hit, "Itoshi no Ellie," was recorded at Onkyo House. 1017 Studio was later called "Southern Studio" and became a place synonymous with Southern, but back then they still loved 401 Studio. I couldn't use it, so I used a multitrack

I was traveling to various external studios with my tape."

Mr. Inomata cites overseas engineers such as George Massenburg, Bill Schnee, Jeff Emerick, and Humberto Gatenooca as influences, but to me, they are just products, finished products. What Hakubun most wanted to know was the process of getting there. "What I learned from watching my predecessors' mic arrangements, EQ, and compressor techniques at Victor Studio has become the foundation of my career as an engineer." At the time, in addition to Hideo Takada, Victor Studio had pioneers such as Tatsuo Umezu (who appeared in the 13th issue of this series) and Teruo Yamaguchi, but later,

The Individuality of senior engineers from the perspective of Mr. Xi Inomata

What was sex like?

"In terms of idol work, Takada-san is Sakurada-san. Ukiko and Umezu are listed as Hiroimi Saki and Yamaguchi

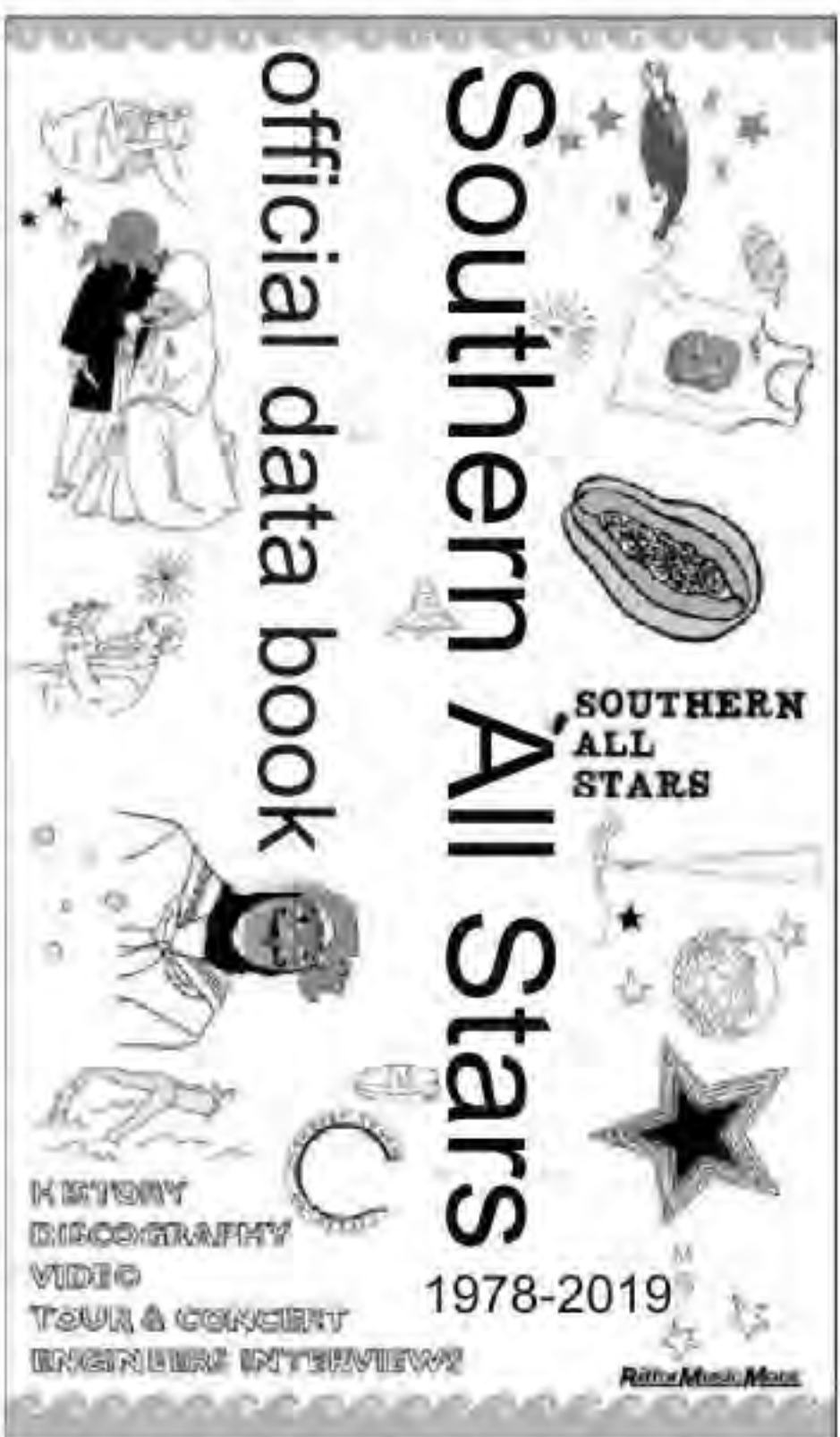

Southern All Stars Official Data Book
1978-2019

(Ritto Music Mook/published in 2019)

History and singles of Japan's leading rock band!

Not only albums, video works, tour introductions, but also past records
A groundbreaking book made possible by summarizing the testimonies
of five leading engineers: Mr. Inomata's testimony is on page 7.

change of the ladies. I have visited each of my seniors' workplaces as assistants many times, and Takada-san and Yamaguchi-san are the type of people who will give you detailed advice when you ask them a question. Mr. Umezu, on the other hand, was the quiet type, and seemed to be told, "If you can steal something, go ahead and steal it." I had seniors of both types.

I think that's why my horizons have expanded. All engineers who have experience in the analog era work really quickly."

After becoming a freelancer,
Works with Miyuki Nakajima and others

In 1981, Mr. Inomata left Victor Studio and became independent as a freelancer, going beyond the framework of a record company and gradually expanding the scope of his activities.

"If Victor Studio was my alma mater, then Shibuya Epicurus was my "place of training". I was able to train a lot, and I was also blessed with many new encounters," says Inoku. Shibuya Epicurus is a recording studio Horive venue established by the Yamaha Music Foundation in 1975, and after leaving Victor 1, Mr. Inomata ended up doing a lot of work at Epicurus. That's the reason Miyuki Nakajima's "Kansui Uo" (2nd year) was offered.

"Shortly after I became a freelancer, I started working as a producer at Yamaha.

I received a phone call from Mr. Yu Okutori, a user. Mr. Okushima was the frontman of a GS band called The Savage before he became a producer, and I loved their song "Forever and Forever," so I froze up as soon as I received the call. (laughs) I wondered what he was talking about, and when I asked him, he said, "I was impressed when I listened to Southern's album (10 Numbers Karatto)."

Main works that Shozo Inomata was involved in recording

hot chest excitement

Southern All Stars
<Victor/Invitation VIH6027> LP



Southern All Stars' debut work, released in 1978, including the debut single "Katte ni Sinbad," which was Mr. Inomata's first work. In addition to the band members, the horn section "Horn Spectrum" led by Spectrum's Ro Niyama participates in arranging and performing. It's a complete package of the energy that is unique to this band.

cold water fish

Miyuki Nakajima
(Canyon Aardvark C28A0208)LP



Released in 1982. Miyuki Kojima's ninth work, created by Inomata from material recorded at Epicurus Studio and 11zaka Studio. Kojima's voice is fused in a high-level with the backing that was performed based on the intentions of arrangers such as Nozomi Aoki, Tsugutoshi Goto, and Masataka Matsutoya. A wide variety of works, including different versions of the single "Akujo".

Saffron+4/Mako Ishino
(Victor VICL77015)CD



Released in 1985. This is his 8th work, released after his return to the entertainment industry after his retirement. Takashi Matsumoto, Kazumi Yasui, and Masumi Kawamura provide the lyrics, Kazuhiko Karai, Tomoka Ueda, and Toru Okada provide the music, and the arrangement is by Akira Inoue and Hiroshi Sato. Written by Shiteha Pop, who was in charge of the song, Ishino's singing voice is well balanced with the glittering backing including the keyboard. High-resolution sound sources are also available.

bad news

A.R.B.
(Victor/Invitation VIH20002) LP



Released in 1980. The second work produced by Ryo Ishibashi (vo), Yoichiro (guitar), Keith (ds), and new member Sanji (Ryoji Nonaka, b). Like Southern, the bend concept was determined by Ken Takagaki's production, and the sound that conveys the instruments and voices to the mountains is impressive, and the agency, which embodies social rock bend, is straight and comfortable.

Delanger

Kenichi Hagiwara
(Tokuma Miyakami Bourbon BMD1015) LP



Released in 1982. Six solo works by Ushihara, who was also active as an actor after working with The Tempters. This is a record that combines Hagiwara's unwavering singing voice with an outstanding sound balance, accompanied by members who are familiar with each other even at live performances. While making orthodox recordings, you can relive the depth and gentle texture that is unique to analog recording. High-resolution sound sources are also available.

stereo solar group

Southern All Stars
(Victor/Invitation VIH28045) LP



Released in 1981, this is Southern's fourth album. The band sound is the centerpiece of this album, and the mature musicality similar to AOR is supported by the participation of strings and a horn section. Engineer Inomata's accomplishments are immeasurable, as he acoustically supported the world of Rocca Barra Do that this work encompasses, drawing you in with its restrained sound production that sets it apart from conventional Southern music.

So I did a mix of Miyuki Nakajima. Kuroda to record it." was the offer. Katsuya Kuroda, but I wanted Masaru was surprised to hear that it was Mr. Okuyama, "You really don't need me." I it Miyuki Nakajima?" I asked Mr. Speaking of Katsuya Kurokawa, is Eckers, Ami Ozaki, Hako Yamazaki, Chi Including many artists such as

death in 2015. songs until his recording of 2 in the was involved Canyon Denipony Director Yaichi Saka Studio Director Na

Delicition/Etsuko Aya
(Teichiku/Continental TECN18062)CD



Released in 1986. This is Etsuko Aya's third album, which debuted in 1981. Aya's coquettish voice is mixed with a new wave sound that brings the keyboard to the forefront. The vocals have a deep echo, and the drum sounds also incorporate the popular sound of the time (=gate reverb). The exquisite sound balance is again achieved by Takehito.

He is a master craftsman in the engineering world. Although Mr. Inoto had a lot of experience, he felt a lot of pressure when Shirami had to mix the sound recorded by Mr. Kurokawa, his great senior.



"In addition, Mr. Okuyama's order was very abstract, and he said, "The strings for the interrogation are inspired by the color of the aurora changing from green to blue." I have no choice but to imagine it in my own way, so when I tried it, people would say, "I think it turned out to be pink instead of blue" (lol).

But in the end, both Mr. Okutori and Mr. Kurokawa were satisfied, and I think it was a good training experience. What surprised me most was Miyuki's expressiveness. Even if they sing the same song about heartbreak, they sing two different songs. For example, there is one take in which she sings as if filled with sadness, and another in which she sings simply as if saying, "I've forgotten about that guy." They are entrusted with the task of "using whichever one they prefer." I thought, "This person is a genius."

By creating sound

The important thing is

I feel good

whether

Mr. Inomata is a white en

Regarding his views on Genia, he says, "It all comes down to whether or not Shirabun feels good when listening to it." It certainly seems like that mindset hasn't changed at all since the days of "Sinbad." Keisuke Kuwata's vocals, which overflow the lyrics in a way that seems overly worded, and the momentum of the band's performance, which runs with the energy that comes from his youth, remain the same, and while he was an assistant, he was a pioneer in the field of popular songs. This is because they put into practice the well-balanced method of accumulating sounds that they probably learned from. Currently, he is a project member of the vocal/piano/violin unit Coralfree, is in progress. Not only the album but also weekly updates. Recording a cover song for YouTube that will be uploaded /I am also in charge of the mix. "Their music has a sensual comfort that cannot be explained with caution, and I'm glad to still be able to work with artists like this." says.

"Now that DAWs (digital audio workstations) are mainstream, we can now use an almost unlimited number of tracks, right? It's not uncommon for us to use more than 20 tracks just to record the drums. I can't record in that way because I've developed the habit of determining the overall balance at the time of starting the sound. I also learn a lot from young engineers and musicians, while also teaching them what they can teach me. I'm having fun doing it."

QUADRAL

Equipped with ring radiator Ricom Σ

SIGNUM series

<Signum series>



new era of speakers

Ring tweeters were previously installed in expensive speakers made by foreign brands.

quadral has independently developed a new tweeter equipped with a ring radiator, "Ricom Σ ". "Ricom Σ " has a unique structure and an excellent high performance

It is characterized by its characteristics and resolution. This improves the sense of sound localization and provides a reliable sound image.

We are proud that the inclusion of a ring tweeter in a mid-class speaker is an epoch-making event in the history of speakers.

We will deliver a new standard to everyone who loves music.



Photo by Kawamura Youichi



■SIGNUM90
275,000 yen (tax included)/pair



■SIGNUM70
217,800 yen (tax included)/pair



■SIGNUM20
126,500 yen (tax included)/pair

For inquiries and purchases, please contact our authorized distributor or our sales office.

NETWORK JAPAN

Network Japan Co., Ltd.



Real Cable

2-16-3 Tamade Nishi, Nishinari-ku, Osaka 557-0045

<https://www.network-jpn.com/>

SOUND MAGIC

Audio Specialist

TEL.06-6105-0707 FAX.06-6105-0708

E-mail: info@network-jpn.com



quadral
home page

Do you know how much your "audio" can sell for?

Free business trip

無料出張査定
 appraisal/purchase

We can appraise any audio equipment! We purchase in three ways: on-site, in-store, and by home delivery. We will give you a free estimate of the purchase price at this moment!

Please feel free to contact us first!

Flow of business trip assessment

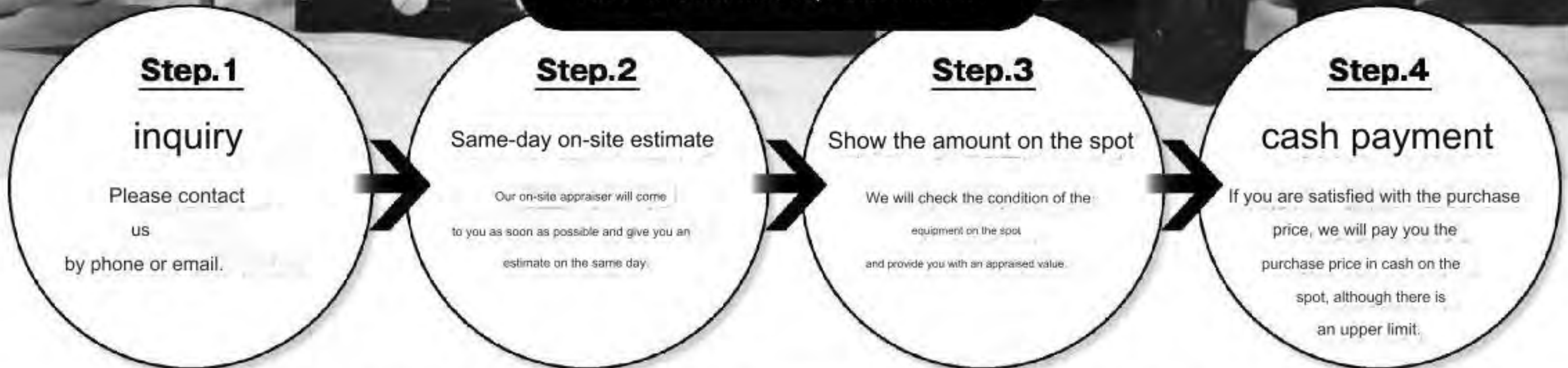

*Depending on quantity and region, estimates may be given over the phone or by email instead of on-site. Please note.

If you have any other audio-related questions, please feel free to contact us.

Please feel free to contact us by phone or email.

045-482-5150
info@rewire.co.jp

Rewire Co., Ltd. 8-24 Tetsucho, Aoba-ku, Yokohama <http://www.rewire.co.jp>

REWIRE **ココ★至柿生**

Tokyu Denentoshi Line 12
To Machida



Carefully selected gems from
around the world, your ideal sound
from Kamani

Kamani recommended famous machine



ESOTERIC
grandioso K1X



ESOTERIC
K-01XD



ESOTERIC
grandioso T1



McIntosh
MA8950



Mark Levinson
No5206



Mark Levinson
No5302



Mark Levinson
No5101



TRIODE
EVOLUTION



TRIODE
JUNONE 845S



DELA
N1Z/3



LINN
SELEKT DSM



SOULNOTE
S-3



Reed 5A/Reed 5T



DS AUDIO
Emm Labs
DS-EQ1



MAGICO
A1



MAGICO
A3

MAGICO
A5



DYNAUDIO
Confidence 20
Confidence 30
Confidence 50
Confidence 60



YG Acoustics
Hailey 2.2
Vantage



DS AUDIO
Grand Master



DS AUDIO
DS W3



DS AUDIO
ES-001

Displayed items and USED items are limited to actual items. Please be sure to check stock availability by email/phone/fax before placing your order. We also recommend that you visit each store to see, listen to, and confirm your desired product directly. Please feel free to contact us at our store, and we also handle mail order.

Used sales

Model

SPEAKER

ALTEC A7-X	¥330,000
DALI OPTICON 6 (BK)	¥148,000
mbi 121	¥498,000
QUAD ESL57 Double Stack (Mark Levinson HQD genuine frame)	¥638,000
JBL TS6000	¥178,000
TANNOY Yorkminster... ..	¥680,000
DYNAUDIO FOCUS360 (ROSE) ..	¥398,000
FOSTEX G2000a (U/G)	¥648,000
B&W 801F (series80)	¥220,000
Wilson Audio Sophia series3 (Dark Titanium)	¥1,580,000
Wilson Audio System7 (BK)	¥1,280,000

AMP

ROTEL RHB-10 (with original box) ¥165,000

First Watt SIT-1 (with original box)	¥880,000	LINN AKURATE DS/K/3 (BK KATALYST exhibit)...	¥780,000
Pass Labs XA60.5	¥580,000	Accuphase DP-800+DC-801	¥800,000
UESUGI U-BROS10... ..	¥238,000	EMT 927st (with suspension)	¥Ask
Mark Levinson ML-7L	¥480,000	ROKSAN Xerxes20 Plus (U/G Upgrade Plinth,XPS-R,SME 3010-R)	¥598,000
Mark Levinson ML-3	¥440,000	Mark Levinson No.37L+No.360L ..	¥480,000
McIntosh C22CE (with wood case)...	¥380,000	Clear Audio Concept MM Package ...	¥168,000
McIntosh MC275GOLD	¥440,000	LINN AKURATE DS/K (SILVER) ...	¥280,000
Pass Labs XVR1 (2way)	¥440,000	DENON DCD-SA1.....	¥178,000
Pass Labs XVR1 (3way)	¥715,000	ROKSAN Radius3 Basic	¥154,000
Monarchy Audio SE-100 Delux ..	¥158,000	Pro-Ject 2-Xperience JPN (exhibit)...	¥158,000
UREI525....	¥148,000	ESOTERIC P-0s (U/G)+6N-DC12 ...	¥450,000
Cello Encore1MΩ (Phono)	¥780,000	TEAC X-10M (manufacturer maintained).....	¥110,000
Pass Labs X2	¥178,000	ORTOFON EQA-1000-	¥165,000
C.R.Development Woodham 300B Classic (WE300B)	¥248,000	Clear Audio Basic Symmetry Limited ...	¥88,000
Audio Research D-90	¥180,000	dCS Veldi La Scala (SACD not available)+Elgar Plus+Velona	¥1,100,000
PLAYER		marantz NA-11S1-	¥148,000
LUMIN U1 MINI (BK exhibit)	¥260,000		

The listed price includes consumption tax.

<http://www.stereo.co.jp/>

Latest arrival information/bargain information/trade-in information etc. updated daily!

K Kamani

Yoshikawa Main Store: 1392-2 Sakaemachi, Yoshikawa City, Saitama Prefecture 342-0050

TEL. 048-981-4344 FAX. 048-981-4368 kamani@stereo.co.jp

Koshigaya store: 617-1 Osugi, Koshigaya City, Saitama Prefecture 343-0005

Kamani Ltd. TEL.&FAX. 048-971-6781

Bank of Tokyo-Mitsubishi UFJ Koshigaya Ekimae Branch Current Account 1009905

Business hours: 10:00~20:00

Business hours: 10:00~18:00

Closed: Sunday

OVC audio & visual specialty store

14 stores in 10 prefectures nationwide

BALANCED : <https://corp.avac.co.jp/Avac>

search

Classic Bashamichi Store Full of popular audio equipment. Yokohama's premier high-end audio specialty store



A pure audio specialty store located in the Bashamichi area of Yokohama. A large number of domestic and international speakers and audio components are placed in the spacious interior of the store, allowing you to enjoy the experience to your heart's content.

- Address: 〒231-0014
4-45-1 Art Building 4F, Tokiwa-cho, Naka-ku, Yokohama, Kanagawa Prefecture
- Telephone: 045-319-6985
- FAX : 045-319-6986
- Closed: Tuesdays and Wednesdays (advance reservation recommended)
- Business hours: AM11:00-PM7:00
- E-mail: bashamichi@avac.co.jp
- 3 minutes walk from the north exit of JR "Kannai Station"
- 2 minutes walk from the municipal subway "Kannai Station"

Classic Fukuoka store

Completeness of B&W KEF Paradigm McIntosh's top-class audio specialty store

A pure audio specialty store within walking distance from JR Hakata Station. In particular, the display of B&W, KEF, and Paradigm speakers is the best in the prefecture. You can listen to the music at your leisure in the calm atmosphere of the store.



- Address: 〒812-0013
1-14-25
Shinkansen Building 2 Building 1F
Hakata Station East, Hakata Ward, Fukuoka City, Fukuoka Prefecture
- Telephone: 092-432-0722
- FAX : 092-432-0723
- Closed days: Tuesdays and Wednesdays (Advance reservations recommended)
- Business hours: 11:00 AM to 7:00 PM
- E-mail: fukuoka@avac.co.jp
- 5 minutes walk from "JR Hakata Station Chikushi Exit"

B&W KEF Paradigm McIntosh enhancement on display



- B&W "800D4" "700S3" Series enhanced display
Main exhibition store Classic Bashamichi store/Classic Fukuoka store/Shinjuku main store Reinforced exhibition store Yokohama store/Nagoya store/Umeda 店
- KEF [BLADE2] "Reference Meta" "R" Series enhanced exhibition
Main exhibition stores Classic Bashamichi store/Classic Fukuoka store/Shinjuku main store Reinforced exhibition stores Yokohama store/Nagoya store/Umeda store
- Paradigm [PERSONA] [FOUNDER] "PREMIERE" Series enhanced exhibition
Main exhibition store Classic Bashamichi store/Classic Fukuoka store/Shinjuku Main store/Yokohama store/Nagoya store/Umeda store
- Martin Logan exhibition begins
Lineup Classic Bashamichi store "ClassicESL9"/Classic Fukuoka store "ESL-XGM"

Trade-in in a different category Visit multiple points!

If you purchase using trade-in, you can save money all year round!!!

20% UP!!

Declaration of enhanced trade-in!!!

Monday, August 2, 2021~

Trade-in value of Audio & Visual products increases by up to 30%!!

If you're looking to replace your audio product, Avac is the best deal! If you trade in for a new product, we'll trade in for up to 30% more than the normal appraised value. Our customer's product grade with a higher appraisal value than anywhere else.

We will strongly support you. ① Trade-in appraisal is 20% higher than the normal appraisal value!!

② If you purchase a trade-in item from us, the appraised value will increase by an additional 10%!!

Estimated purchase amount is
Please see the ABAC USED-OUTLET page.



MC3500 McIntosh tube amplifier

A vacuum tube monaural power amplifier that incorporates everything McIntosh has learned. Using the latest parts to meet modern standards, it delivers performance worthy of a legacy model number.



Manufacturer's suggested retail price (pair)
4,840,000 yen

C12000 McIntosh tube amplifier

The dual-chassis, dual-mono design completely separates the power supply circuit, microprocessor, and control circuit from the audio circuit that handles the music signal, completely eliminating noise.



Manufacturer's suggested retail price
2,530,000 yen



Please contact us regarding special price offers.

Pure floor speakers! Which brand do you prefer?

E-4000 and 804/D4 are both new products and go well together.



804/D4 speaker

A state-of-the-art drive unit and highly rigid reverse-wrap cabinet deliver excellent performance.

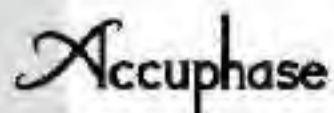

E-4000 integrated amplifier



Manufacturer's suggested retail price
693,000 yen



Manufacturer's suggested retail price (pair)
2,020,000 yen

The powerful power of the E-5000 demonstrates the ability of the A-3.



A-3 speaker

Newly designed
Adopts 28mm beryllium diaphragm

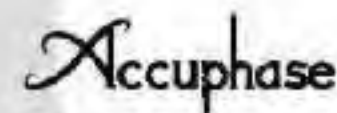

E-5000 integrated amplifier



Manufacturer's suggested retail price



Manufacturer's suggested retail price (pair)
2,145,000 yen

Flexible and dynamic

The sound of TAD resonates,
Class A operation unique to the E-800

T.A.D.

Evolution Two speakers

Well-balanced
beryllium tweeter realizes mid-high range reproduction

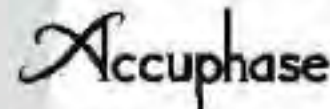

50th anniversary model E-800 integrated amplifier



Manufacturer's suggested retail price



price 1,333,000 yen
Manufacturer's suggested retail price (pair)
1,628,000 yen

Leave the power of choice and price to us! We also accept trade-ins.

2022
Accuphase
climax
viewing party
12/17

DP-1000 SACD player

High rigidity and high precision construction. Realizes SA-CD/CD drive, quiet and elegant drifting disc loading mechanism, signal system and powerful power supply unit with separate drive system, spindle. The motor has an "outer rotor type bra" By adopting "Silent DC motor" (United States only). Equipped with a live mechanism. Furthermore, We2 pair HS-LINK has independent data and clock transmission is possible.



Manufacturer's suggested retail price
1,430,000 yen

DC-1000 D/A converter

Accuphase 50th anniversary model
Digital Processor ESS Techno
BMSD (DSD signal) • BMSD++ (PCM signal type
D/A controller that drives circuits of ESS9038PRO
manufactured by ESS corporation in parallel
Equipped with battery.



Manufacturer's suggested retail price
1,430,000 yen

C-3900 control amplifier

Speaking of Accuphase, domestically produced audio
It is a representative audio brand.
Speaking of its flagship products, the domestically produced G
This is probably the amp that represents Do.



Manufacturer's suggested retail price
2,220,000 yen

A-300 A class power amplifier

Class A operation power MOSFET 20000
push-pull output stage, 125W/80
which exceeds the previous model.
Achieves class A operation of
250W/40, 500W/20, 1,000W/10 and
ideal constant voltage drive.



Manufacturer's suggested retail price (pair)
2,970,000 yen

Used items that are of interest

Western Electric monaural power amplifier



Equipped
with General Electric
Company

USED special price **748,000 yen**

Western Electric 300B vacuum tube



Perfect era
New, unused!
(The inside is not empty. Opened to take photos) Dirt and scratches.

USED special price **168,000 yen**

ALTEC LANSING VALENCIA 846B speaker



Vintage look for the cabinet

USED special price (pair) **165,000 yen**

All prices
include tax

High price trade-in/purchase
month <https://www.audio-marou.com/>



MOVIE AUDIO REFERENCE AND ORIGINAL
3-31-20 Showa, Hakodate, 041-0812

inquiry

TEL.0138-46-0005

FAX.0138-46-1270

Email address net@maro.ne.jp



You can listen to it in
a 40 tatami space.

Main new products



If you would like to purchase new or used audio, please contact the specialty store U-AUDIO.

AU-AUDIO

Closed: Sundays and public holidays

Uaudio.com Co., Ltd. 1F Sumitomo Jimbocho Building, 3-25 Kanda Jimbocho, Chiyoda-ku, Tokyo 101-0051

TEL: 03-6256-9002 www.u-audio.com

You can pay online for both new and used items on this site. We accept various estimates and consultations.



High-end audio and theater specialty store Shimamusen

All prices include tax.

Full of event information and bargain product information!

<http://www.shimamusen.co.jp/>

2% return sale

During the period, you will receive a 2%
cashback on purchases
over 10,000 yen!

In-store shopping credit

We will cover the splitting
fee for up to 18 times!

(*Principal amount 150,000 yen or more)

New listening room completed at CYMA



AEX Audio Equipment Award 2023 Award-Winning Products, Shimamsen Specially Selected Products at Special

Accuphase

[monaural power amplifier]



A-300 ¥1,485,000 (1 unit/tax included)

Accuphase

[stereo power amplifier]



P-7500 ¥1,485,000 (tax included)

LUXMAN

[Belt drive analog player]



PD-191A ¥990,000 (tax included)

LUXMAN

[SACD/CD player]



D-07X ¥825,000 (tax included)

ESOTERIC

[stereo power amplifier]



S-05 (Silver) ¥990,000 (tax included)

ESOTERIC

[Network player]



N-01XD ¥1,760,000 (tax included)

VERTERE

[Belt drive type analog player]



MG-1 PKG MK2 CL
(Clear finish)
¥1,815,000 (tax included)

audio-technica
[Iron core type cartridge]



AT-ART20
¥330,000 (tax included)

Accuphase

[Integrated Amplifier]



E-4000 ¥693,000 (tax included)

TRIODE

[vacuum tube integrated amplifier]



EVOLUTION ¥560,000 (tax included)

B&W

[Speaker]

702 S3
(Gloss Black)
¥1,139,600
(tax included/pair)

TRINNOV

[Sound Optimizer]



ST2 HI FI ¥1,276,000 (tax included)

MARTEN

[speaker]

PARKER
DUO (Piano Walnut)
¥1,694,000 (tax
included/pair)

DYNAUDIO

[speaker]

Confidence20
¥1,870,000 (tax
included/pair)

FINK team

[speaker]

KIM ¥1,980,000 (tax included/pair)

TAD

[Speaker]

TAD-CE1 TX
¥2,970,000 (tax included/pair)

B&W

[speaker]

801D4
(Gloss Black)
¥5,456,000 (tax included)

YG ACOUSTICS

[Speaker]

Halley2.2
¥9,460,000 pair tax included)

Used items Bargain

information *Some speakers cannot be shipped to local areas, so please contact us. *We apologize if the item is sold out.

B&W

800D3 PB Used
item (pair/shipping not included)

Special price
including tax ¥2,980,000

TANNOY

Canterbury 15 Used
(Pair/
Shipping not included)

Special price including tax
¥950,000

AVALON

Ascent MKII used
item (pair/
shipping not included)

Special price including tax
¥920,000

PIEGA

Coax 70.2 Used
item (pair/
shipping not included)

Special price
including tax ¥950,000

mark evinson

Power Amplifier

No20.5L Used
item (pair/shipping not included)

Special price including tax ¥950,000

Monaural KREL power amplifier



FPB-300CX Used item (shipping not included)
Special price including tax ¥620,000

Accuphase



C-2850 New (shipping not included)
Please contact us for special price!

LUXMAN



MO-500 Exhibition item (shipping not included)
Special price including tax ¥1,284,800

THORENS Log Player

Prestige
3012R Gold
RMG309 Limited Used
item (shipping not included)

Special price including tax ¥3,200,000

LINN

analog player



LP12
AKITO
TRANPORIN Used item
(shipping fee not included)

Special price including tax ¥430,000

JBL



D44000 Paragon (mid-term model)
(shipping not included)

Special price including tax ¥4,400,000

B

JEFF ROWLAND power amplifier



Model9 TI HC Used item
(shipping not included)

Special price including tax ¥2,400,000

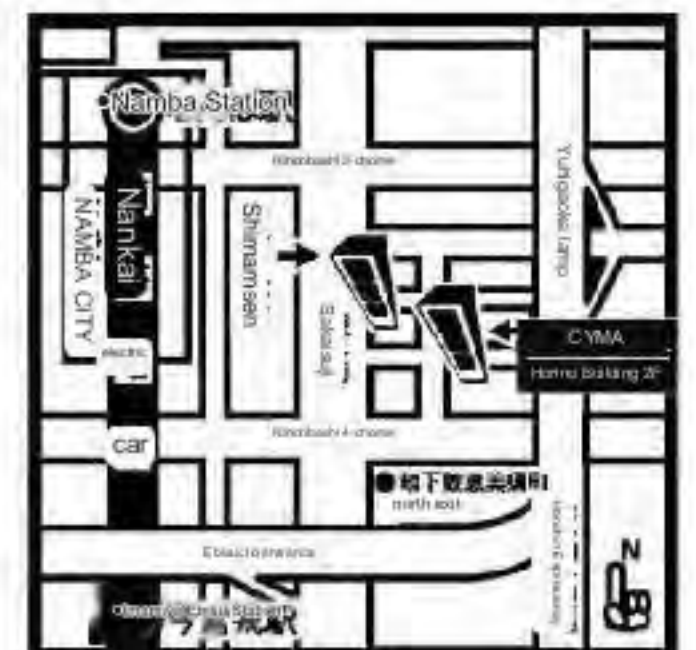

Sound and video specialty store

Nihonbashi Denden Town

Shimamsen

4-8-11 Nihonbashi, Naniwa-ku, Osaka 06 (6632) 2851

•Business hours/AM 10:30~PM 7:00 •Closed
days/Every Thursday, 3rd Wednesday of every month

*All product prices include tax.

We also accept orders by phone or fax.

TEL: 06 (6632) 2851

FAX [1F]: 06 (6632) 2540

FAX [2F]: 06 (6641) 2299

Payee

Sumitomo Mitsui Banking Corporation Namba Branch Current

Account No. 233200 Mitsubishi UFJ Bank Namba Ekimae Branch Current

Account No. 0000000 *Products may be shipped after payment is confirmed.

*Shipping charges will be charged separately.

“Each of the engraved sounds comes back vividly.”

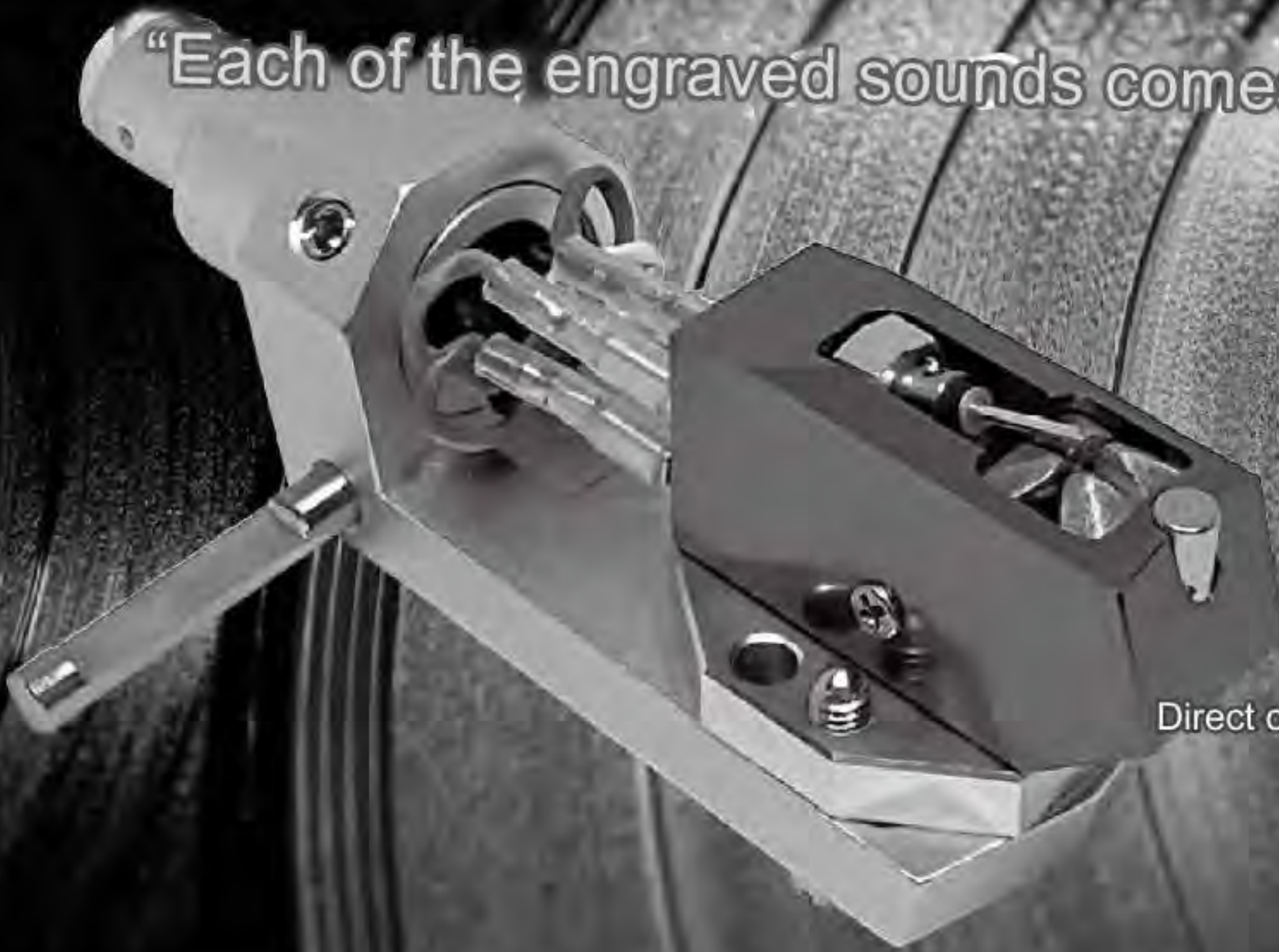

Direct couple cartridge with a pentagonal coil installed close to the stylus

MC-F1000

After six years of continuous trial and error and overcoming challenges to create the ideal sound since 2016, the MC-F1000, a further evolution of the direct couple method, has finally been born. The lightweight coil allows for a quick rise in sound and sharp expressiveness that vividly reproduces the emotion of the music engraved on the record.

A direct couple method that is less susceptible to cantilever transmission loss because the signal is converted before being transmitted through the cantilever.

The cantilever is made of aluminum, which can be press-fitted, to achieve a stronger fit with the needle than with adhesive.



The stylus, cantilever, and left and right coils are tightly connected using hard adhesive. The home base-shaped pentagonal coil has little output change due to changes in stylus pressure. Stable against warping and shaking. The

effective diameter of the microcoil is 17μ ultra-fine wire. The 0.8mm hollow structure reduces weight and brings out even the smallest nuances. In addition, the body has a strong integrated design.

The weak points of the direct couple method are solved by the MagneClean method, which attaches a strong magnet to the tip and attracts magnetic dust from the board surface.



You can check the details and behind-the-scenes story behind the completion of the MC-F1000 by scanning the QR code on the right.

MC-F1000

Tentative price ¥440,000 (tax included)

Accessories: Head shell MITCHAKU, stylus cleaner SASUPA

Specification

- Format: Direct couple MC cartridge •Stylus force: 1.3g to 1.6g (recommended range)
- Frequency characteristics: 8-45,000Hz Output voltage: 0.18mV 5cm/sec 1kHz lateral
- Coil impedance: 62 •Effective coil diameter: 40.8mm 4 turns of 17μ wire for a total of 12 turns on the 3rd floor
- Self weight: 8.4g •Height of needle tip: 17mm •Mounting screws: 2 types: untapped and tapped
- MagneClean method to block magnetic dust



New winter models

Thorough listening

WILSON AUDIO
Alexx V

DALI

Kore

MARTEN

Mingus Quintet 2 Statement Edition

B&W

70253/70353/70553

MARK LEVINSON
ML50

BURMESTER

216

ACCUPHASE

A300

LUXMAN
PD191A

DS AUDIO

DS-W3 Cartridge / DS-W3 Equalizer

FIDELIX

MC-F1000

PILIUM

Alexander / Hercules

Hiroji Onodera

Nobuyuki Fu

Takahito Miura

Tadashi Yamanouchi

Hiromi Wada

EXCITING
COMPONENTS

exciting components

WILSON AUDIO Alexx V

A sense of realism that makes you feel as if you were actually there in the hall.
Stereo playback can reach

The ultimate three-dimensional expression is here

— Tadashi Yamanouchi





The company is MTM (Mid Tweeter Mid). This unit also uses the same unit arrangement. Ru. The center tweeter is from Juten. To further expand the dynamic range, Equipped with a carbon fiber rear chamber **Convergent Synergy** (Carbon) is installed for the first time, to the midrange of the Like the high-end model Chronosonic XVX, magnetic Alnico magnets are used in the circuit.



The enclosure has the latest version. Based on X material, depending on key points Uses V material with strong vibration damping properties. For MTM, similar to Chronosonic XVX It has an open gantry structure. Ga The two mid-range units installed in the The enclosure is designed to disperse back pressure. Fuser structure reduces back pressure He is said to be increasing his speed.

Elimination of unnecessary resonance and Improved time axis accuracy Working together for important effects It is clear that It's bright, stereo tansaku The ultimate position that can be reached Here is the expression for rest.

Wilson audio top

The latest technology was introduced to the Alex, which is positioned next to the Chronosonic XVX, and the Alex lower was born. By inheriting the structure of Kami-Kei's unit holder held by an open gantry from the flagship model, and at the same time combining a part of the enclosure using Monologue's X material with V material with improved vibration damping performance. An important point of evolution is the thorough elimination of unnecessary resonance. Furthermore, this is the first time that a CSC tweeter with an acoustic diode in the spike section and a carbon fiber rear chamber has been adopted. This spout was created by Darryl Wilson, who is responsible for the generational change of the brand, and his strong desire for development and passion for technological innovation.

Alex V's majestic appearance and price of over 30 million yen (tax included) are unmatched by other companies.

Although it is not a flagship class, the company's In other cases, higher-end models exist, and there is virtually no cost constraint when identifying the technology. The idea behind this idea is that there are technologies that can only be achieved by delving into that area, and that by accumulating these techniques we can expand the realm of expression. What we should be concerned about is how to pass on this ultimate technology to sister machines, and the Alex series can be seen as an example of this. Although it is hard to say that it has come within reach, it is still a good idea to foresee future developments in the middle range. The significance of this speaker's existence is great. An important advantage of the gantry structure is that it allows for the smooth flow of air that only a skeleton can provide, but in addition, it also significantly increases the rigidity of the enclosure as a whole. In addition, the woofert section and gantry flap

It is also worth noting that vibration control has been further strengthened by incorporating materials in multiple locations such as the frame, acoustic diode, and spikes. The time alignment accuracy brought about by the MTM (midrange tweeter midrange) array arrangement should improve even in the dynamic domain, so we can expect further improvements in spatial representation. The wait swells. To confirm the three-dimensional reproduction power of the stage, listen to Bartok's "Concerto for Orchestra" with the Helsinki Philharmonic conducted by Markki. The contrast between the parts within the thick group of stringed instruments and the image of the woodwind group floating in the background are vivid, and the way the horns and percussion instruments wrap around the whole from the very end is a perspective just like the real thing. Not only does the speaker disappear,

I felt so close to Yah. It was also my first experience. I could taste it. I was also shocked by the tense atmosphere of the Bill Evans Trio's "Behind the Dykes." On Eddie Gomez's bass, the left hand that jumps up and down the fingerboard and the movement of the stone finger that brings out the instantaneous power that can be heard even on repeated notes can be seen in the mouth, and the play of the three players.

Wilson Audio Alexx V

¥29,000,000 (pair)

- Model: 4-way 5-speaker bass reflex type
- Unit used: Woofer: 32cm cone type + 27cm cone type, mid bass 18cm cone type, mid-high 15cm cone type, tweeter 2.5cm dome shape
- Sensitivity: 92dB/W/m
- Impedance: 4Ω
- Dimensions: W400 x H1,610 x D680mm 227kg
- Note: The finish and price shown in the photo is the main body. Standard color: Quartz, Saran net: Le Mans Blue, body finish
- Other options include Galaxy Gray, GT Silver, Carbon, and other prices.
- Various types including upgrade color (¥30,000,000/pair) etc.
- Yes, Saran Net available in various colors
- Contact: Stellar Co., Ltd. 03(3958)9333

DALI Kore



dali

Kore

¥15,000,000 (pair)

•Model: 4-way 5-speaker bass reflex type •Unit used: Woofer, 29cm cone type ×2, midrange 18cm cone type, tweeter 3.5cm dome type, super tweeter - ribbon type •Crossover frequency: 390Hz, 2.1kHz, 12kHz Sensitivity: 89dB/ 2.83V/m •Impedance: 40 •Dimensions/weight :W448×H1,675×D593mm. 160kg •Inquiries: D&M Customer Service Center 0570(666)112

Infused with thoughtfulness to help you listen to music comfortably. A powerful sense of dynamism and Presenting music that is full of life - Takahito Miura

Dali, breaking news in the summer issue of this magazine

KOR E, the super dreaded speaker system, has arrived in Japan. The company, which has produced flagship machines such as the Megaline and Skyline, has finally announced the long-awaited KORE. The original form is said to be the 2008 design concept "Eminent ME9." Although a prototype was completed, it was a phantom product that was shelved due to the global financial instability at the time. More than 10 years have passed since then, and we have taken the technology one step further by injecting the core technology that improved SMC (Soft Magnetic Compound), which was first used by Epicon, and the know-how from Hakusha manufacturing of drivers. A mountain made of layered plywood KORE was born with the inclusion of war. Mountain molded engine What I am particularly interested in is the balanced Rosua is and environmentally friendly magnetic circuit that dramatically increases the driving force. The drivers in the low and mid-range water-soluble paint range have a glossy magnetic finish on the front and rear.

The winding direction is different in the air gap? Two long voice coils (actually formed from a single wire) are provided to provide efficient amplitude. Moreover, the low-frequency diaphragm has a multilayer structure with a honeycomb structure core sandwiched between distinctive wood fiber diaphragms, making it lightweight and highly rigid. The base part, which supports the total weight of 160 kg, is made of a strong resin composite material made by casting. A dedicated space inside houses the Oshirogawa crossover circuit. The Ogi + high range baffle is made of die-cast aluminum. Beautiful

Amara black pussy

Rosua is and environmentally friendly magnetic circuit that dramatically increases the driving force. The drivers in the low and mid-range water-soluble paint range have a glossy magnetic finish on the front and rear.



Medium height mounted on aluminum baffle
 There are two parts in the range, mid range and low range unit.
 A soft glow and the alloy of aluminum is the feature of the emission.
 <Performing Shincho> Balanced Drive SMC
 A new driver has been installed, moreover
 The midrange diaphragm has a geometric pattern.
 The e said to suppress resonance.

It's up. KORE is being listened to at D&M Holdings in Kawasaki City, Kanagawa Prefecture. Sound source is SA10, a Marantz SACD player.

It was an environment in which Classe's Delta Puri and Delta Mono were connected. Dali's speakers are designed to make listening to music comfortable. The refreshing high range of the hybrid tweeter, which combines a soft dome and ribbon type, and the low-distortion midrange to low range produced by the aforementioned SMC give this impression, but KORE has these advantages. In addition, it has the charm of presenting music with a powerful sense of dynamism and a sense of life.

Ta.

For example, the powerful vocals and powerful kick drum you hear in Sting's "Lashing Water" have a groove that makes your body move. There is no doubt that large-scale pieces are his specialty, such as the intense and courageous melody of Elgar's Symphony No. 1 conducted by van Nboim. The brilliance was also amazing. As for jazz, "You'd Be So Nice to Come Home To" by saxophonist Vittorio Cuculo, who I personally recommend, shows off its happy swing. The sound has an extremely wide range and a high contrast between light and shade.

Dali's KORE teaches you the fundamental joy of audio, which is listening to music with a full-fledged device. It is a super-dreadnought machine from Denmark that uses advanced technology to stand out from the crowd.



Exclusive large carved speaker terminal
 Gold-plated specification compatible with Le Pai wiring
 The crossover network circuit is
 Separated into two parts to minimize mutual interference.
 It is equipped with a 34 kg resistor for low and mid ranges.
 On the backside of the terminal, there are 4 terminals.
 The signal is placed near the aluminum front baffle.
 It is installed in such a way that the route is short.

MARTEN

Mingus Quintet 2 Statement Edition



Marten Mingus Quintet 2 Statement Edition ¥10,000,000 (pair) • Model:

3-way 5-speaker bass reflex type •Units used: Woofer 18cm-dome x 3, midrange 13cm reverse dome, tweeter 2cm reverse dome •Crossover Single wave number: 370Hz, 4kHz Sensitivity: 88dB/2.83V/m•Impedance: 60•Dimensions: W280×H1,090×D380mm/63kg•Notes: Photos and specifications are Statement Edition, others are standard specification Mingus Quintet 2 (¥8,500,000/pair) available •Contact: Stock Zephan 03 (5917)4500

Good bounce, clear and high resolution.

This unit is unique in its exquisite and beautiful sound. — Hiroji Onodera

The speaker system from Sweden's Marten was introduced to the Japanese market about six years ago. Thankfully, I had the opportunity to listen to it right away, and although I was impressed by the outstandingly beautiful finish and solid construction, I felt that the sound was a little too logical for me, and I couldn't wrap my head around its superiority. Even though I could understand it, I felt frustrated as if I could not fully express its excellence either emotionally or realistically.

That impression started to change after I listened to a small system called "Ichika Parker Duo (Diamond Edition)" last year. Originally had

The good basic performance of the music He had lived his life in the direction of entertaining, and Marten's uniquely beautiful sounds were working in that direction. Next, when I heard the majestic sound world of their last album, the floor-type "Parker Quintet (Diamond Edition)," my impression of Marten changed dramatically.

Now, the company's speaker system The series name comes from the classic Jazz Giant. Parker probably derives from bebop founder and alto saxophonist Charlie Parker, and the superlative Coltrane comes from Joe.

Coltrane, entry line Oscar goes to Oscar Peteroso Probably, Parker is one of Oscar's top series, and even higher than that is the Mingus series, named after bass player Charles Mingus. "Mingus" is also the name of the first speaker that Marten announced in 1998, and it has been refined for over 10 years. It's a coming series. The small machine is the latest version of the

Mingus series. An improved model of the previous model "Mingus Quintet" Quintet means quintet, and as the name suggests, the driver unit is

This is the "Statement Edition," which uses Bull's Jorma Statement and has a higher quality crossover network element.

Precise finishing unique to the company The enclosure is equipped with a bass reflex port on the bottom. Unlike the Parker series, it is not equipped with a passive radiator. Another feature of the company's system is that the legs are equipped with isolators that block vibrations, but this part also seems to have evolved in recent years. I think so.

Moderate damping throughout the entire area A sound that is effective, that is, has a good bounce, is clear, has high resolution, and is full of hi-fi pleasure. The three woofers are well aligned, and the connection with the mid-high range is good, allowing for a wide stage. The exquisite and beautiful sound that is developed in this instrument is unique. High quality book It is a class speaker system. It can be said that



Significantly different from its predecessor, the top and bottom plates are made of solid wood, which further strengthens damping. All units, including the diamond tweeter, use Acton from Thiel & Partner.



The rear lower terminal is made by WBT. Single wiring is possible, and there is a knob on top for adjusting the low frequency level. Please note that the audition was conducted in-house. This is the "Statement Edition," which incorporates Yorma Design's Statement in the main wiring and combines it with high-quality crossover components. Bass reflex port is on the bottom

There are 5 pieces. This includes a 0.70,000-inch diamond tweeter, a 5-inch inverted dome ceramic midrange, and three convex 7-inch woofers with aluminum honeycomb cores. I listened to the High-end cable is used as internal wiring material.

B&W's 700 series has evolved from S2 to S3 (Series 3) for the first time in five years. The

700S3 lineup is closer to the top-of-the-line 800D4 series, except that the tweeter diaphragm is not diamond. It is well made. The

change to the enclosure is that the baffle is now gently curved. For this reason, the baffle is thicker in S3 than in S2. At the same time, the circular part of the frame of the 2-way woofer is thicker, making it more sturdy.

—Tweeter is S2 carbon

This is similar to the carbon dome, in which carbon is sprayed onto the surface of the aluminum material to create a carbon dome. As a direct descendant of the Nautilus, B&W has a tube at the rear of the tweeter that acts as a muffler. Although it is not visible when the tweeter is installed in the enclosure, there is a tube inside. In S3, the tube is longer and the cutoff frequency is lower. In the case of tweeter-on-top (the tweeter rests on an enclosure dog board), the

B&W

70253/70353/70553



A neat and beautiful sound.

The sound field has a wide spread and the sound

image is three-dimensional ———— - Fu Xinhua

The tube is similar in length to the 800D4 series. The shorting ring in the tweeter's magnetic circuit was made of copper in the S2, but was made of silver in the S3. When the silver Continuum Cone is used in the midrange, the damper (spider) changes from the traditional shape to a narrow bio-mimetic suspension similar to the midrange of the 800D4 series. The woofer cone of the S3 is the same as the S2, and is about a centimeter thick at some points, giving it

Ta. All three models introduced here are tweeter-on-top models. The effect of having the tweeter mounted on top of the enclosure, rather than on a baffle, is to widen the sound field and add a refreshing sense of air, while also making it easier to listen to in a reverberant cathedral. In the recording, you could even feel that Hitoi seemed to be very proud. The compact 705S3 is outstanding in terms of sound image focus sharpness. Words from a 2-way concentrated sound source.

It's as if you can see tiny particles scattering around. The 703S3, which is a floor-standing type with a light rhythm even though the woofer supplements the bass range, offers a great view of the sound field and gives off a sense of atmosphere. Good balance. However, when I listened to the 702S3, I was amazed by the rich listening experience. It extends well into the ultra-low range, making the performance more dynamic and making the music more persuasive. The three-dimensional sound image is realistic. Although the 702S3 is priced at over 1 million yen for a pair, it is still a good value for money, and all three models are perfect branch.

I have listened to all 700S3 series models, which have 6 models excluding the center speaker, and when I compared them with the S2, I found that the sound was smoother, smoother, and had a beautiful, neat sound. In addition, the sound field has a wide spread, and you can hear that the sound image is three-dimensional.



View of 705S3 from above. The curved baffle is used on all 700 series models, and the driver - The unit is placed in front of the baffle. The latest generation tweeter, which is located independently above the cabinet, has a longer channel. The silver cone-shaped diaphragm with the tube system is the same as the previous model. A damper cone is used, but the 3-way machine has a damper part that responds to the 800D4 series. The biomimetic suspension provided. It is said that unnecessary coloring is suppressed.



B&W 702S3(Photo right) ¥1,036,000 (pair)

•Model: 3-way 5-speaker bass reflex type •Units used: Woofer 16.5cm cone x 3, midrange 15cm cone, tweeter 2.5cm dome crossover frequency Number: 350Hz, 4kHz Sensitivity: 90dB/2.83V/m • Impedance: 80 • Dimensions Weight: W290×H1,138×D410mm. 33.5kg•Note: The size and price shown in the photo are gross and bra Satin White, Mocha, and Rose Nut (¥990,000/pair) are available at separate prices.

703S3(Photo Center) ¥900,000 (pair)

•Model: 3-way 4-speaker bass reflex type •Unit used: Woofer, 16.5cm cone type x 2, midrange/15cm cone type, tweeter/2.5cm dome type crossover frequency Number: 350Hz, 4kHz Sensitivity: 90dB/2.83V/m • Impedance: 80 • Dimensions, weight: W290×H1,117×D372mm 26.8kg •Note: The finish and price shown in the photo is gloss black, and other prices include satin white, mocha, and rose nut (¥860,000/pair)

705S3 (photo left) ¥512,000 (pair)

•Model: 2 way 2 speakers, bass reflex type •Unit used: Woofer, 16.5cm cone Tweeter/2.5cm dome type Crossover frequency: 4kHz Sensitivity: 88dB/2.83V/m•Impedance: 80•Dimensions Weight: W192×H413×D337mm 9.6kg•Note: The finish/price shown in the photo is gloss black, separate price is satin white, Mocha, rose nut (¥490,000/pair) available, dedicated stand FS700S3 as an option (¥114,000/pair) Yes •Inquiries: D&M Customer Service Center 0570 (666)112

MARK LEVINSON ML50

Mar, one of the world's most famous high-end audio brands.

Clevinson celebrated its 50th anniversary. The journey of this Yen brand has not been smooth, and at the same time, I feel that its sound character has undergone several changes. Nevertheless, the fact that it has remained a top brand for half a century can only be praised as a great accomplishment

To commemorate the company's 50th anniversary, This machine, ML50, was developed. This monaural power amplifier is limited to 100 sets worldwide. The materials state that it is the ultimate expression of the brand's essence and passion for great sound, and this is clearly reflected in its appearance.

So let's start from there.

First, let me point out that "ML" has returned to the model number. Recently, the company's products have been using the "10," but the ML was used during the brand's initial system. I have fond memories of products such as the ML2L power amplifier (1977) and ML7L preamplifier (2011). The revival of this model number is proof that the people involved with Mark Vinson today have an interest in and respect for the history of the brand. "I can say that, but surprisingly, there are a lot of people these days who don't know the history of the brand and don't have any pride in it (or should I say, they don't have any interest in it). Isn't that a bit of a happy event?"

Natural sound image expression and wonderful reverberation.

Suitable for commemorative model

An amplifier that makes you feel a new era - Hiroji Onodera





There are 2 speaker terminals. It has one unbalanced and one balanced input system. There are also RS232 for centralized management, Ethernet, and a USB port for internal software updates. The sole is an isolation foot with an internal structure to reduce vibration.



Place the lance in the center of the large power supply with the "50" mark. Furthermore, it is equipped with a large-capacity filter capacitor with a total capacity of 206,800 μ F. Maximum power is 425W (at 8 ohms)

In terms of appearance, the handle is said to be inspired by the 1020L (1988), which was announced with a new system, and the legs were made from popular models such as the 1033L (1999). The glass front panel and red logo that stands out are inherited from the 1053 (2008), and the basic design of the amplifier is inherited from the 10536 (2015).

The beautiful internal structure can be seen through the glass top panel (with red LED lighting). The design features of the ML50 include thorough shielding and minimizing electrical and mechanical noise. Strengthening the power supply,

The operating voltage and current have been optimized to achieve a power of 125 watts (8 ohms) (up to 20 watts can operate in class A range). The use of a foot with a vibration-damping structure also likely contributes to sound quality. Dimil Danyuk was the main architect of the design, and he and a team led by Danial Simiaei are working on the development from an office relocated from Connecticut to Northridge, California. Vivid based on a tone that is accurate enough for reference.

Adds a sense of color and creates a monaural composition. See the profound bagengen in Hiroto from Radano.



Mark Levinson ML50 ¥5,500,000 (pair)

- Output: 425W (8 Ω), 850W (4 Ω) •Input sensitivity/impedance: 2.83V 30k Ω (unbalanced), 2.83V 60k Ω (balance) •Dimensions/Weight: W438 x H197 x D533mm 52.2kg •Notes: Limited to 100 pairs worldwide
- Contact: Harman International 0570(550) 465

Great sound

Ru. The clear sound image expression with no contours gives it an extremely natural feel, and the dynamic sound that increases in power without stress is also wonderful.

Furthermore, early Mark Levinson Reminiscent of a naive nuance

There are some parts where you can get a glimpse of the car, making it a model that is suitable as a commemorative model and gives off a feeling of

A NEW GTR.

BURMESTER

216

Exactly one year ago, in this magazine, Germany

I wrote an audition report for Burmester's flagship model, the "159 | monaural power amplifier." The company, which started in 1978, is a high-

end brand that represents Europe, and the 159 has an amazing appearance (and the price is also amazing).), it was an isolated entity even from the previous lineup of the same brand. The 159 was completed in accordance with the wishes of the founder, Dieter Burmester. Equipped with a variable damping factor function. However, regardless of these functions, the scale and majesty of the sound is so overwhelming that it is difficult to cite any other example.

The "Kiki 216" is a stereo power amplifier developed based on the brilliant results of the 159. This is (probably) the first newly developed power amplifier since the death of the company's founder, who was also its designer.

The price is one-tenth of the 159 when it was announced, but this is because the 159 is special, making it an imposing high-end

model.

Previously, Burmester had stubbornly given the model number "911" to models in this class, but the fact that they have now added a new model number indicates that the company is marking the start of a new generation. I think it can be seen as a display model. Furthermore, 216 means June 2021.

Techniques inherited from 159 to 216 There are two major technical topics. First, to minimize warm-up time, it measures the temperature inside the amplifier with great precision and makes adjustments based on that value, reaching the optimal operating point within minutes of power-on. circuit technology. The model to be tested for stereo sound must be powered on and warmed up the night before. As you can see, the amplifier circuit is



Careful attention was paid to every corner.

Both delicate and powerful.

With a dynamic feeling
 entertain ————— Hiroji Onodera

Maintaining the right temperature actually improves sound quality.

This is one of the reasons why some enthusiasts don't turn off the power to their amplifiers.

With this unit, the amplifier's controls can bring the amplifier into optimal condition in a short amount of time, which is a simple but very welcome feature. Second,

copper heat pipes are placed in the middle of the housing to efficiently dissipate heat throughout the housing, keeping both the amplification section and the power supply section at an optimal temperature. As mentioned above, temperature is very important for amplifiers, so this also affects sound quality. It is believed that this has contributed greatly to the

it will be done

The amplifier section has a fully balanced input stage and a 4-parallel push-pull output stage, and the power supply section has a large toroidal transformer and a total capacitance of 188,000 microns.

Composed of Arad capacitors.

As a result, 165 watts x 2 (4 ohms) has acquired the power of This is

a very nice sound, precise and clean. It combines delicateness with careful attention to detail and agile power, with a refreshing

taste and a pleasant aftertaste. leave. Neatness elegant and neat

However, dynamic

With a sense of dynamism Entertaining service The sound is Lumester's

Feel the new generation something that makes you feel was.



The final version has the minimum necessary configuration. The input end is only balanced, and number 3 is hot remains unchanged. Equipped with 1 pair of speaker terminals.



Remove the top plate and look inside of the center board.

Underneath is a capacitor of 47,000 µF per piece.

Four custom-made electrolytic capacitors and a humanoid shape

The current section that performs the toroidal transformer is hidden. So

On the left side (from the rear) are the input stage and output stage, and the input stage is Burmester's monologue.

Adopts the fully balanced circuit "X-Amp". Note that there is a capacitor in the signal path.

By using a DC coupling configuration that does not use

It is said that it is being received. A copper heat pipe is attached to the output element and The entire structure is designed to function as a heat sink.

Burmester 216 ¥4,350,000

•Mountain small: 165W+165W (40), 490W (when BTL is expanded, 40) •Input sensitivity/impedance -Dance: 0.77V/1.9kΩ •Dimensions/Weight: W496×H191×D479mm, 35kg •Inquiries: Kabu Noai 03 (6902)0941

ACCUPHASE A300

flag from Accuphase

monaural power A

A300 is released. Ship's

producing up to 1000W with an ohm load.

class A amplification, is capable of

has been released since 2017 and has

as a magazine reference The A300, which

the company's 50th anniversary. Also used

The successor to the A250, which is celebrating

This is the appearance of a masterpiece.

the A250 has an 8 ohm load.

outputs 25% 100W. On the other hand,

With the output element M, this A300

production, and increased to 125W!!

made by Toshiba, which has completed

were made by Fairchild, the OS/FFT was

However, since a total of 20 parallel pushes



Accuphase A300 ¥2,700,000 (pair)

●Output: 125W (80), 250W (40), 500W (20), 500W (80 when connected to BTIL) Sensitivity/Impedance: 1.26V/20k (Unbalanced
 ●S), 1.26V, 40k (balanced) ●Law/Weight: W465 x H240 x D515mm /46kg ●Contact: Accuphase 045(901)2771



The rear panel terminal layout follows the A250. Bi-wiring compatible humanoid in addition to speaker terminals, it has one each for balanced and unbalanced power. The operation mode can be set to normal, bridge normal, or bridge using the operation switch. Switch to bridge reverse, Noh (2 units required in bridge mode)



Peak inside. On the A250, the filter capacitor is in front and the power transformer is in the back. However, with this machine, the power transformer is located at the front, and the filter capacitor is placed at the rear. The output element MOS-FET is from Toshiba to Fairchild, changed to manufactured.

power decorating the 50th anniversary model country. Takahito Miura depicts realistic performances with breathtaking vividness.

There is no change in the composition of the pull. The increased output is due to a newly developed toroidal power transformer with increased capacity than that of the A250. Improvements in the ratio of output to noise, or so-called signal-to-noise ratio, should also be focused on. The A250 also boasts an extremely excellent value of 127 decibels, but the A300 has a fully discrete configuration aiming for the lowest noise ever.

By developing a Lance input amplifier, we are leading the way. It is said to have achieved an astonishing signal-to-noise ratio of 130 decibels. In addition, with an output impedance of less than 8 milliohms, the damping factor is guaranteed to be over 1000, and actually measured to be over 2000, which is impressive, exceeding the A250's 1400. The company's technical team continues to develop electronic circuits and carefully examine the elements used to improve various characteristics.

I listened to the A300's sound in the Accuphase listening room and compared it to the A250. I transferred the sample sound source I brought with me to DELTA, an audio-only NAS, and used a USB-connected DC1000 for output, a combination of a C3900 preamplifier and a B&W 801D4. Many of the songs used in the speaker feature in the previous issue of this magazine include Jennifer Waugh.

The A300 clearly had a more

sculpted and three-dimensional sound image of the male and female vocals in "Jeanne d'Arc", and the localization was solid.

The same goes for the pronunciation of musical instruments.

Tonal balance is A25

Not significantly different from 0 It seems, but the low range is A

300 is tighter

The outlook of the sound field space is also

good. Welsler-me

Strike conductor Cleveland

The orchestra's performance of "Don Juan" was spectacular. The brightness of each note is heightened, and the power of a full orchestra is also beautifully expressed. What moved me the most was Keith Jarrett's 1981 drive in Bregenz, Austria, and Munich, Germany. The A300 performs a realistic piano solo with a sense of tension as the audience watches, with breathtaking craftsmanship. I drew it and charmed it.

For a long time, the company's monaural power amplifiers have been characterized by parallel drive of two completely identical amplification circuits, one on the left and one on the right. This is to increase the output current and lower the output impedance at the same time, but without fear of misunderstanding, he says. "To tell you the truth, I had the impression that the interaction between the left and right panels was becoming closer. Class A amplifiers shift to class AB operation when the rated output exceeds the class A operating range, so if you are listening to a sample sound source and feel that the power is insufficient, I couldn't feel anything.

LUXMAN PD191A

Finest analog from Luxman

Introducing the player PD191A.

The company, which has been in

this field since the 1960s, released the

PD171 in 2011 after a long

hiatus, and was praised by audiophiles

seeking authentic analog recording.

Later, the improved PD171A and

lower model PD151 were released.

PD151 Mark 2 was released in

May of this year.

The development of the top-of-the-line model

PD191A was based on the well-received PD17.

This is in no small part related

to the problems that have arisen

with IA. In consideration of

the impact of the new coronavirus's

global spread, JELCO (Ichikawa

Jewelry), a long-established tone arm

manufacturer, decided to end its audio business.

Since the tone arm was no longer being

supplied, both the PD17 IA and

PD151 that were equipped with it were

on the brink of being discontinued... There

is a proverb that says, "Turn a disaster

into a blessing." Luxman is doing well.

Luxman's

Top class AD player. Takahito Miura

has a quick response, clear information,
and a wealth of information.



In order to rebuild the old analog player products, we decided to explore a new tonearm and develop a turntable that would surpass the performance and sound quality of the PD171A. The result is the PD191A introduced here.

The company that took the lead in terms of tonearms was the SAEC, which took the world by storm with its double knife edge system. It is not made by audio engineering from the past, but by the company that is working on the WF4700 in 2019. Through joint development with Ec-Commerce, a newly designed 10-inch universal tonearm was completed. The LTA710 tonearm, equipped with a lightweight aluminum pipe and single knife-edge vertical bearing, was adopted.

At the same time, Luxman's engineering team began developing a turntable worthy of a top-of-the-line machine. The motor that uses a belt to rotate the 5.2 kg heavy-duty platter, which is machined from aluminum, is a brushless DC type that has been adopted since the PD151 (the PD171A is an AC type). The motor drive circuit with sine wave PWM and PID control method is an analog player.

Ideal for storing heavy items on the platter of this machine.

optimized: main chassis

The top plate, which also plays the role of, is made of 15mm thick aluminum. The sub-circuit is suspended here, and the vibration source motor and power transformer are placed floating on the bottom plate, achieving high vibration damping performance despite being a single body. I'm listening to PD 191A in the Luxman listening room. Since the sound quality of a phono cartridge + equalizer amplifier is dominant in analogue sounders, I compared it with the PD171A to find out its sound quality.

To put it simply, the strength of the core is impressive, as the capabilities of the rotation system and arm are synergistically demonstrated. For example, "Two Tricorn Hat" has a rich sound and is rich in information. "D. Fagen" has a quick response when the sound starts, and a wide audible range. In "War Requiem," the delicate expression in the bass range was impeccable, and I was able to enjoy a performance with excellent stability. excellent a drive circuit with sine wave PWM and PID control method is an analog player.



The tone arm installed in this machine was developed by Siesco for two years, and was developed in collaboration with SAEC. Newly developed. A knife-edge mechanism with excellent initial sensitivity is adopted for the vertical bearing. It is characterized by the fact that Of course, it is also possible to replace the tone arm, and it is also possible to replace the tone arm. An arm base that corresponds to the arm, and a universal arm that can be processed for the arm of Benevolence. An optional arm base is available.



The rear terminal is only a power inlet, and the black screw visible on the left is a dust cover (sold separately). For attaching the first metal fitting. Fino cable is 5 pin type

Luxman PD191A ¥900,000

Tone arm section (LTA710) •Model: Static balance type •Spindle between bots: 240mm Compatible cartridge weight: 4~11g
 Turntable section •Drive method: Belt drive •Revolutions: 33-13, 45, 78rpm platter Monthly weight: 5.2kg Dimensions, weight: W491×H128×D399mm /24.8kg•Notes: Head shell included, optional dust cover, heavy way, various arm bases, etc. •Inquiries: Luxman Co., Ltd. 045 (470)6991

DS Audio has released the DS W3, which is loudly proclaimed as a new reference model for optical cartridge systems.

DS-W3 cartridge is conventional

It is the successor model of W2, and is the company's third model.

Generation machine (Grandmaster and 003)

Adopts the same internal structure as is the biggest feature.

i.e. detect music signal

LED and photodetector for

(PD) to the left and right channels.

Install each independently (optical system position optimization). At the same time, the light shielding plate, which vibrates according to the movement of the vibration system (changes in brightness/darkness at that time are detected by PD), was changed from aluminum to solid beryllium, making it both smaller and more mysterious.

This results in an extremely low effective

The advantages of the optical cartridge are

maximized, and the output voltage is increased from

40 to 70 mV. This can be said to be a major

achievement in that the signal-to-noise ratio of the cartridge

white body has greatly improved and the

background has become quieter, as the amount of noise

has increased significantly while the amount of noise

has remained the same. Also, channel separation

has been improved (more than 27 products/1

DS AUDIO DS-W3 Cartridge DS-W3 Equalizer

k) and especially high frequency separation.

The good news is that the number has

increased by 10. The vibration system is

a combination of a boron cantilever and a line contact needle. The body and base are

made of aluminum, and the base is integrally

processed to increase rigidity.

The audition for W3 was held at a white house. strength

From "Blue Note All Stars", which has a

tremendous dynamic range, to "Mascarello",

extremely fresh sounds with an impressive level

of transparency came out. Compared to the

general MC type and MM type, the impression

is that the goldness is minimal, and the digital

Clear and high speed. I feel a

remarkable evolution in the

mesmerizing kindness.

Hiromi Wada



DS audio

DS-W3 cartridge ¥450,000

•Power generation method: Photoelectric type •Output voltage: 70mV (3.54cm/sec, 1kHz) •Stylus pressure: 1.85~2.05g (appropriate needle piece: 1.95g) Own weight: 7.9g

DS-W3 Equalizer ¥850,000

•Phono equalizer for DS audio optical cartridge •Dimensions Weight: W450 x H120 x D435mm. 13.5kg •Notes: Low Cutoff width available in 4 levels •Inquiry: Stock Digital Stream ☎042 (747)0900

Musical sounds such as saxophone, drums, and bass suddenly rise up from a quiet background like a file or a CD playing and rush towards you. This intense dynamic is not good for your heart. The clear, high-speed sound easily surpasses what I imagine a typical phono cartridge to be like. The thickness and extension of the low range is as expected from the optical cartridge, and in Zubin Mehta's Holst's "Planet", the depiction of a scene and the reproduction of a pipe organ with a roaring ultra-low tone make you feel right at home. I was able to experience the feeling of loneliness floating in the dark universe.

In Barbara's

rendition of "Pierre," her voice is extremely delicate, and the detailed descriptions create a sense of intimacy that makes you feel her body temperature. This soft, hard singing voice with a hint of warmth. I'm not leaning towards it.

The softness of the sound and the reproduction of clear, fresh sound are largely due to the combined W3 equalizer. This is because the performance of this machine has been significantly improved compared to previous models, such as by increasing the board thickness from 1.6mm to 2mm and the copper foil thickness from 35μm to 170μm. This W3 equalizer amplifier has a wonderful design, and I would love to use it with a W3 cartridge. With this combination, I could feel the high purity of the sound, as well as the momentum that seemed to be breaking out, and the signs of rapid evolution.



The rear of the DS-W3 equalizer has one optical cartridge dedicated input terminal and an ultra-low One system each of balanced/unbalanced output terminals with different cutoff values. Output 1 is equipped with a 6dB/oct filter, output 2 is 12dB/oct. 30Hz/50Hz cutoff frequency switch at the top center. A total of 4 patterns when combined with It is possible to set ...



Inside of equalizer amplifier, large size There are many electrolytic capacitors. It can be seen that several parts are arranged and connected by copper plates. Equal in the rear The structure has been compactly organized to make the mountain path as short as possible. substrate. The thickness of the previous model has been increased from 1.6mm to 2mm, and the thickness of the copper foil has been increased from 35μm to 170μm. By soldering the older brothers of the resistors that have been upgraded to μm. A common feature of the company's equalizers is that they have improved signal quality.



FIDELIX MC-F1000

Fidelix is an audio manufacturer headed by Naka Ogawa. Man He joined Sony after dropping out of school, where he was involved in the design of the T AL120F, and also worked at Stax for about three years. He was 7 years old when he defeated Fidelix in 1976.

This MC F1000 is a so-called direct power generation type MC type pheno cartridge with a power generation coil mounted on the needle. The mechanical structure is modeled after the condenser type that the company attempted in 1990 (only 5 were manufactured due to manufacturing difficulties), and a similar structure can be found in Victor Japan's MC-L10 00. What immediately comes to my mind as a modern MC type using direct power generation method is the A time when there were no tars or cantilevers.

The current product is Audio Technica's AT'ART1000.

The power generation coil for the channel is in the field. It has 5 shapes similar to the home base of a 角 ball, and its overall diameter is extremely small, approximately 0.8 mm. There are two of them, one on the left and one on the right, above the solid diamond hands. Since it is an air core 二 type, the 0.8 and power output are low, and the recommended stylus force is 1.3 to 1.6 grams with an impedance of 6 ohms. The load impedance is 6 ohms or more, but the company ideally aims for a gigaohm range. The front is equipped with a magnet that prevents magnetic dust and dirt from entering the magnetic gap. I'm listening to Fidelix's MC "1000" in the Kishi listening room. phono equalizer amplifier accurate



Fidelix MC-F1000 ¥400,000

•Generation method: MC type •Output voltage: 0.18mV (5cm/sec. 1kHz) •Internal impedance S:60 •Stylus force: 1.3~1.6g Own weight: 8.4g •Notes: Head shell "MITCHAKU" and style Laser cleaner "SASUPA" included •For inquiries please contact Fidelix 042 (493) 7082

The distance from the tip of the needle to the power generation circuit is almost zero. Shocking clarity with no sense of ambiguity ————— Takahito Miura

The C47 has a maximum load impedance of 1 kilohm.

The first time I heard Anselmet conducting "111

"Kaichouko" suddenly has an incredible amount of information, and it is shockingly clear with no sense of ambiguity! General MM/MC

types have a distance from the tip of the needle to the power generation circuit, but this book in the case of machines, it is almost zero. The image of converting the amplitude information of the sound engraved in the groove directly into electric signals is

amazing. However, it is never a flashy sound.

There isn't. "Maxine" from Donald Fagen's

"The Nightfly" has a bright tone starting from the piano at the beginning, and even when the vocals are overlaid with the sounds of electric instruments, it doesn't get muddy. A red color that reproduces the unique transparency often found in early digital recordings. I was always amazed by the raw sound.

There was none.

Dave Grusin Direct

I can safely say that "Detective

Bantha's Theme" from the album "Discovered Again" was one of the best

performances I've ever heard. The stylus tip has an oval shape rather than the trendy line contact shape, but the sound was clear with excellent resolution.

I listen to other analog records, but I fell in love with Teresa Teng's "Tsugu Nai" released by Stereo Sound because of her charming singing voice. This machine is it is a masterpiece of air core MC type.

This magazine's sister magazine "Tube Karikun" has a tube-

type tube made of wood with a built-in step-up transformer.

I was listening to it with a phono equalizer amplifier, and I was able to get a sufficient S/N ratio and enjoy the vivid sound that is characteristic of the MC/F1000.



Close-up of the cantilever tip. A coil with a diameter of approximately 0.8 mm is at the tip of the needle. Adopts a direct coupling type arranged in two parts, not circular. The pentagonal coil increases stability against shaking and twisting.



MITCHAKU" head shell connector part included with MC-F1000. At the top, the guide pin moves like a seesaw, allowing the tone arm to be in close contact.

and their popularity is increasing overseas. and Esteron have finally landed in Japan, Super popular pyriums such as Magico amplifier that produces high-quality speakers, it was chosen, and the topic started as an brand in Munich and was so impressed that separates. First of all, the author heard the Ta. I have great memories of the flagship and the preamplifier Alexander amplifier, and the power amplifier Hella, Cress (Hercules), both the hero (Alexander) plans are based on names that symbolize confidence is evident, but the company's established in 2014. The company's founder's The company is new, having been

PILIUM Alexander Hercules

of pyrium

Dreadnought separate amplifier

First landing in Japan.

There is no chaos down to the smallest detail.

Watch everyone's movements from the podium

As if you can see through it --- Tadashi Yamanouchi



Pyrium

Alexander ¥7,000,000

•Input impedance: 30kQ (unbalanced), 60kQ (balanced) •Dimensions and weight: Honkyu· W480×H170×D490mm 29kg, power supply· W480×H100×D490mm.25kg

Konstantinos Virios

Other than the description that he is an audio enthusiast, we don't know much about his background, but it's immediately clear when you see the actual equipment that he has an insatiable inquisitive spirit for finding good sound.

It is clear that there is no compromise in all elements, including circuit design, cylindrical structure, and component selection, and that the design is done with no consideration given to cost considerations, and that all production is done by hand at the company's headquarters in Athens. The preamplifier uses four separate cables to supply the control system and audio from the power supply section in a separate case, and the monoblock power amplifier also supplies the control system and amplifier circuits completely from the power inlet, be independent. Because the transformers and capacitors are made of large-capacity, high-performance parts, each power amplifier weighs 107kg (total weight 268°C!), including the preamplifier itself and the power supply.

He is a heavyweight who seems to be going against the grain. The fully balanced design of the Alexander is characterized by a volume circuit design that minimizes the signal path, and one of the two XLR channels is equipped with a monologue P-channel that eliminates capacitors from the signal path. Adopt Link specifications. Hercules is a 2.5km long power transformer.



Hercules ¥12,500,000 (pair)

●Output: 350W (80), 700W (40), 1,400W (20) ●Human sensitivity/impedance: 1.15V 80KΩ ●
Dimensions/Weight: W400 x H410 x D490mm/107kg Contact: Naspec Co., Ltd. 0120-932-455

It has a built-in powerful power supply circuit consisting of a 2400004F custom capacitor and a total of 30 power transistors. Ensures linear power of 350W at 80, 700W at 40, and 400W at 20. The company's headquarters knows all the details of each transistor's characteristics, such as its amplification factor (hFE), so even if a problem should occur, it can completely restore its original performance.

Connect Buri Power 1 question with PLink mentioned above and download B&W in the magazine's listening room.



Alexander rear preamp. The main unit and the power supply are separate casings, and the two are connected using four Speakon cables. The main unit (top photo) has a panel layout for left and right channels, and has three balanced and two unbalanced input terminals. One of the two output terminals is balanced, and the other is a unique P-Link terminal prepared exclusively for connection with company machines.

Proceed with trial listening on 801D4. I'm sorry to use an analogy, but the moment I first heard the sound, it reminded me of the view from the top of a mountain with a 360-degree view. The stage on which a large orchestra is staged is clear in every detail, making it seem as if you are observing everyone's movements from atop the podium. You can clearly see the movement of all the woodwinds, and the sound shapes of the harp and viola, which tend to be obscured by other instruments, stand out clearly. There are no limits to the expression of perspective, and the sense of distance from the instruments at the back of the stage and the lingering sound that fills the hall is enough to leave you stunned.

I'm nervous even though the resolution is extremely high



The rear output terminal of the power amplifier Hercules is bi-wired. A large one. Input is balanced terminal only. The power inlet is the amplifier section.

Another feature of this machine is that it is divided into two parts: one for personal use and one for control.



Inside the Hercules, the 14-parallel push-pull configuration Yamanki element stands out. Along with the casing, there is a super large 2.5kVA power transformer and a 24F. There are several filter capacitors installed.

Analytical details without harshness
 It is very unfortunate that there is no over-emphasis on the **That's strange. brass ensemble harmo**
The knee is smooth, and the violin's a
 The tack has a core even on high strings, and has a lot of momentum.
 Demonstrate your full strength. What kind of sound source do you listen to?
 Even if the amount is increased, it will become saturated.
 There was no sign, and when I noticed it, it was quite large.
 Despite the sound pressure, there is still plenty of room.
let Speaker designers use wooden machines
 I understand why you would want to choose it.



Digital Components

Amplifier

Analog Components

Other Components

ew

2023 WINTER

Review Listen to the hottest new products

Component

speaker system

- Audel U-Basik 5/8 P394
- Avantgarde Trio G3+SpaceHorn Twin-Drive
- +SpaceHorn Single-Drive** P386
- Fine Audio Vintage Twelve P388
- Krypton KX3SX P411
- Piega Coax 611 Coax 411 P390
- Spendor A4 P410
- TAD TAD-CE1TX P392

SACD/CD player

- Denon DCD1700NE P413
- Technics SL-G700M2 P396

cd player

- Nmode X-CD5 P412

digital file player

- Electrocompanier ECM 1 MKII P415

digital file transport

- Lumin U1X P414

Power Amplifier

- Esoteric S05 P400
- Wooden U Bros 330AHWE P398

Integrated amplifier

- Accuphase E4000 P404
- Macintosh MA9500 P402

phono cartridge

- Ortofon MC Diamond P417
- Phasemation PP5000 P416

phono equalizer

- Deepas Model 1 P406
- Krell K300p P418
- Meitner Audio DS-EQ2 P419

music server

- DELA N1-S38-J P408

Switching hub

- DELA \$100/2-C-J P408

Zerolink dedicated USB bridge

- Soul Note B3 P420

Hiroji Onodera

Nobuyuki Fu

Kenji Mayuzumi

Takahito Miura

Koji Yamamoto

Tadashi Yamanouchi

Hiromi Wada

Avantgarde's all-horn system evolves into "G3"

speaker system

Gorgeous and full of emotion. A unique sound world

Kenji Mayuzumi



Germany's Avant Garde Acoustic will celebrate its 30th anniversary in 2021, and to commemorate the occasion, "Rio G3+ Space Horn" was announced. This all-way all-horn system was first released in 1991 as a 3-way model, which became a unique combination of a 3-way satellite system and a low-frequency horn, and then became the G2 about 20 years later, and a few years later, it was later improved to "XD," and now evolved to "G3."

Compared to the previous work, although the low-frequency horn with an aperture diameter of 55 m and the Ogikawa horn with an aperture of 55 cm are the same, the shape of the horn that supports them, each driver unit, and even the lowest frequency horn of the space horn and the built-in amplifier are different, an ambitious work with all aspects renewed.

First, all 4-way driver units are newly installed.

It was measured. The 200mm diameter low-frequency driver XL3 for the Trio G3 and the 50mm diameter Ogi driver XM3 both use a dome-shaped diaphragm to reduce distortion between the diaphragm and the horn throat. A new air chamber was installed. The XT3 tweeter's diaphragm shape has been changed from a dome shape to a ring shape, and the diaphragm diameter has been increased to 25 mm, extending the Takajo city production limit to 28 KHz. Spherical combined with this The horn has also been newly designed, with an aperture diameter of 20cm (25% increase in radiation area compared to the previous model) and a horn length of 176mm (about twice that of the previous model). In addition, in "Trio G3", each dry

avant garde

Avantgarde Trio G3+SpaceHorn Twin-Drive +SpaceHorn Single-Drive

¥47,370,000 (set)

aligned semi-physically, making the design more sophisticated. The frame has a tweeter. The acoustic centers of the slubbers are to allow fine time alignment adjustments. Furthermore, significantly strengthened, and a slide mechanism has been incorporated. The mechanical strength of the base frame has also been horn length has been increased to 1.9m (in the previous work). characteristics. The space horn shape has been improved, and the has been extended to 1.4m) to improve low frequency horns use one 30cm diameter XB12 driver per side, which and parametric EQ. The "Single Drive" and "Twin Drive" (500W or 500W x 2), and has a built-in digital crossover. It is equipped with a dedicated Senkawa power amplifier.



It is.

That was 6 years ago when I took the esoteric test.

room for the latest work, I was shocked. I listened to the previous work in the listening I experienced with Avant-Gal, but when the deeper emotion and sense of fulfillment a full-scale model. I was shocked by effects that could only be expressed using In the previous work, I was able to express the overwhelming sense of scale, making it unrivaled. model has a "bewitching sound" and an as graceful and full of emotion. The latest to it, a sound that could be described instruments or the voice, had an aromatic quality band. Ru. Every sound, whether it was the an avant-garde setting, such as a small jazz It's like listening to a live performance in the evolution and deepening of the field never stops.

You can immerse yourself in the atmosphere where it seems so.



The control section of "Space Horn". In addition, USB-B terminal. By connecting to a PC using the or LAN terminal, (It is said that it will be possible to make detailed adjustments using DSP.)



Placed in the center of the frame (supporting the unit, etc.) Connecting terminals of "Trio G3", left and right channels channel assignments, internal/external amplifier connection settings, etc. We will also do it here. Since a cover is provided, it can be The rows are carefully designed so that these terminal groups are not exposed. There is. In addition, optional ITRON current drive power Amplifier modules, etc. are attached to this frame.

Avantgarde Trio G3 Model: 3 way 3 speakers Unit used: Woofer, 20cm dome driver + speaker Felical horn, midrange 5cm dome driver + spherical horn, tweeter 2.5cm ring driver
 -+Spherical horn•Crossover frequency: 600Hz, 4kHz• Cutoff+ 100Hz•Sensitivity: 109dB/W/m•Impedance: 190•Dimensions/Weight: W950×H1,694×D986mm 140kg•Note: Price is for full active version John's iTRON current drive power amplifier module (¥5,500,000/pair), AVG/AMP-SW, ITRON/external power -Includes amplifier selector switch module (¥600,000/pair), finishing with "Horn: Berry Venus (¥400,000), Und Ring: Copper (¥150,000), Spike Absorber Element: Racing Orange (¥120,000), Fray The price of the press is ¥22,370,000, and various other finishes are available.

There are options.

SpaceHorn Twin-Drive Model: Subwoofer with built-in power amplifier Unit used: 30cm cone type + hole x 2•Playback frequency band: 20~200Hz•Power amplifier output: 500W x 2•High frequency cutoff, frequency: 20~500Hz (Cute)•Dimensions/Weight: W1,018×H748×D1,165mm 150kg•Note: The case and finish in the photo is stainless steel. Align finish (single specification ¥14,000,000/hair), separate specification (¥14,250,000/pair) with gold copper hair liner The top and bottom plates in the photo are finished in dark wenge as standard, and various other finishes are available.

SpaceHorn Single-Drive •Model: Subwoofer with built-in power amplifier •Unit used: 30cm cone type + hole *Re-frequency band: 20~200Hz *Power amplifier output: 500W *High cutoff frequency: 20~500Hz (possible (changed)•Dimensions, weight: W1,018 x H492 x D1,165mm 110kg•Note: The price and finish of the listening device are stainless steel and hair. Line finish (single price ¥11,000,000/pair), separate price (¥11,250,000/pair) Gold Copper Hairline

There is a jinage. The top and bottom plates in the photo are dark wenge with a standard finish. Various other finishes are available.

•Inquiries: Esoteric Co., Ltd. AV Customer Service Office 042(356)9235

The first 12-inch unit in Fine Audio's new series "Vintage"
 Enchanted by the warm and rich sonority of the playback



speaker system

Hironori Wada

Fine Audio Vintage Twelve ¥4,700,000 (pair)

•Model: 2 way 1 speaker, bass reflex type •Unit used: Woofer/Tweeter, 30cm cone type/7.5cm dome type
 Compression driver - horn type coaxial •Crossover frequency: 750Hz Sensitivity: 96dB/2.83V/m •Impeder-
 Weight: W572 x H1,102 x D591mm.77.1kg Contact: Axis Co., Ltd. 03 (5410)0071

Fine Audio has announced the new "Vintage Classic." Both are groundbreaking speaker systems that utilize the latest technology created by Batan Noi's chief engineer, Dr. Paul Mills. The first thing you will be surprised to hear is that from the classic and chic enclosure of the Vintage Twelve, a modern and fresh sound with an unexpected elegance and excellent clarity and resolution flows out.

The Vintage Twelve is the first model in the Vintage series to arrive in Japan, and is equipped with the company's proud dual concentric (same-side 2-way unit) large-diameter 12-inch driver Ain-Flare.

At the bottom of the enclosure there is a bass tube. An in-cavity is provided, and Fine Eau de Noo's patented BassTraxport tube diffuser is installed on the bottom of the cabinet, dispersing bass energy evenly throughout the room 360 degrees.

It is characterized by the use of a down-fire method. The front baffle is equipped with a golden circular dial type presence control that can increase or decrease the 2.5k to 5k ratio by 3B. this is vocal Fine control of the frequency band



The coaxial unit "A" can be said to be the icon of the company's machines. Equipped with "Soflars", various paper industry materials are used for the woofer. Multi-fiber cone mixed with Compression driver diaphragm used The material is titanium. Equipped with conventional F1 series aircraft The difference is that the edge part is called a fine flute. It's made of rubber with carved parts that will be exposed.



The rear part has a band of approximately 750Hz to 26kHz. 3dB, front band from 2.5kHz to 5kHz Equipped with a dial that can be adjusted by 3dB. under The black part of the A bass track that emits low frequencies from the reflex port. It is a "cus" port.

It means that you can do it, and the newness of your singing voice. You can further fine-tune the timing. The rear side is also equipped with a controller that can increase or decrease the energy in the low and high ranges, so by making full use of both, you can adapt it to the acoustic characteristics of the room or adjust the sound quality to suit your taste. Will. It is also worth noting that this unit's isoflare driver is of the latest specification, achieving clearly directional sound radiation, and producing a rich stereo image even in off-axis locations. I want to do it.

The cabinet was made by a traditional woodworker. Real wood carefully selected by Dobuild An elaborate and luxurious item that is elaborately assembled. Although this is the company's latest speaker product, the classic cabinet materials of oiled walnut and dark burr walnut have been deliberately chosen (I think). However, the wooden machine

The sound that came out was crystal clear, with no hint of turbidity or dullness, and the fact that it was such a glossy, clear sound was an extremely surprising experience that felt almost magical to me.

A standard song for auditions, conducted by Anselmet, In the "Waltz of the Flowers" from "The Nutcracker," the strings and woodwind ensemble create a beautiful, fragrant sound, and the deep overtone that gently rises from it leaves me stunned. I smiled and was enveloped in a sense of euphoria, captivated by Nyu's warm sonority. The Tannoy has long been well-regarded for its classical music and has many loyal fans, but even when listening to contemporary jazz on this unit, the beautiful sonority of the wood grain is accompanied by a sense of dynamism. I can only say that he is very open-minded. I was deeply impressed by its excellent sound field feel and ability to adapt to any program source, and at the same time, this sound became deeply engraved in my memory.

The Coax series, which is the core of Piega, has evolved into Gen2.

Powerful, clear and smooth sound

speaker system

Nobuyuki Fu

Located on the outskirts of Zurich, a world city in northern Switzerland.

PIEGA at the factory
speakers are produced

There is. cone-shaped driver

(unit) is a specialized manufacturer

- is supplied by

Solliloquy's ribbon driver,

which has a coaxial structure between the midrange and tweeter, is

manufactured in-house. The enclosure is made of extruded aluminum.

The person who was in charge of designing the enclosure explained the reason for using aluminum for the enclosure: it can be made into a white mountain shape, and it can be strong even if it is thin, so it can increase the internal volume. ing.

The new factory-manufactured

enclosure is said to be able to produce complex

extrusion molding with higher

precision than the aluminum factory in

Chengju, which was previously requested.

Coax 611 (right photo) ¥2,840,000 (pair)

●Model: 3-way 3-speaker with bassive radiator Units used: Woofer 16cm cone type x 2, midrange/tweeter Ribbon Eye axis, passive radiator 16cm cone type x 3 Crossover frequency: 450Hz, 3.5kHz Sensitivity: 90dB/W/m² in type Peedance: 40●Dimensions/Weight: W210×H1,170×D310mm-45kg●Notes: The finish and price shown in the photo is black with a bottom plate, there is also a model without a bottom plate (¥2,750,000/pair), etc. White finish, silver available for separate price (¥2,650,000/pair)



crossover with fur

One frequency is received at 450 and has a wide take-back area. The delicate sound extends beautifully and long, so the music floats in the air. But that's not all. If you

Reinforcements have been added. The sturdiness of the reinforcement is not comparable to the previous original Coax series. The reinforcement of the

Gen2 Coax series introduced here is its strength, which combines both pushing force and pulling force from inside the enclosure. The amount of force applied was apparently determined by laser analysis of microscopic deformations on the enclosure surface.

Structure that can drive aluminum cones with large amplitude

The woofer is the original Coax series

It has the same tuning as the

The coaxial ribbon driver has been improved.

Damping foil was pasted on the ribbon diaphragm, and magnetic circuits located at the front and rear of the ribbon were supplemented. Rod-shaped neodymium magnets are now embedded in the frame, which has become approximately 30% thicker to 4 mm. The change in appearance is that a magnetic bar runs vertically through the front and center of the tweeter. The previous tweeter only had a magnet at the back, but with this improvement, the tweeter

-The magnetic flux density in the magnetic circuit has further increased.

The challenge for Piega speakers in recent years has been to match the speed with the ribbon by achieving both bass output and speed. I could hear that the results of these improvements were reflected in Coax 411 and 611. Coax611 has 5 166cm units (Three of them are passive radiators without a drive unit), but the bass doesn't get too loud.

What both models have in common is that the sound of the ribbon driver is dominant. Actually

have the impression that Ribbon is a light sound, it has a strong sound that is full of emotion and has a clear presence. The acoustic guitar's arpeggios are crisp and the piano trills sound as if they are rolling. clarity And it's a smooth mountain.

And it's a smooth mountain.

The small Coax411 is the previous Coax It is approximately 5 cm taller than 311.

The Coax411's sound is very well-coordinated, and the sound is louder than its size. Yes, Biega specializes in small speakers.

The special stand (sold separately, Stand 300) looks great.



Coax 411 coaxial ribbon (C112+), ribbon unit

The frame that fixes the kit is thicker than before. It was firmly attached to the front plate.

Furthermore, the tweeter also features neodymium magnets at the front and rear.

This reduces the magnetic flux density.



Coax411 rear. Terminal is bi-wired

correspondence. The bass reflex port is located at the rear. On the other hand, Tallboy's 611 is a passive radio. It is a tar type. The same model, which became Gen2, has an internal Bracing replaces the previous "inside-out" pressure

In addition to force, there is also a mechanism that pulls from the outside to the inside.

Added "TIM2",

Piega Coax 411 (left photo) ¥1,500,000 (hair)

●Model: 3-way 2-speaker bass reflex type ●Units used: Woofer 16cm cone type, midrange tweeter ribbon type
 ●Crossover frequency: 450Hz, 3.5kHz Sensitivity: 90dB/W/m ●Impedance: 40 ●Dimensions/Weight: W210×H450×D310mm, 25kg●Note: The finish and price shown in the photo is black, white is available, and silver is available at an additional price (¥1,400,000/pair).
 Special stand for ingredients "Stand 300" (¥260,000/pair) is sold separately ●Contact: Furen Coordination 0120-004-884

TAD's medium-sized bookshelf "CE1" has been converted to TX by brushing up the unit etc.

Clean and transparent. Expanding musical panorama



speaker system

Nobuyuki Fuji

TAD TAD-CE1TX ¥2,700,000(pair)

•Model: 3-way 2-speaker bass reflex type •Unit used: Woofer, 18cm cone type, midrange/tweeter, 14cm cone type/3.5cm dome type coaxial •Crossover frequency: 250Hz, 1.8kHz Sensitivity: 85dB/2.83V/1m •Impedance: 40 •Dimensions/Weight: W287×H510×D447mm 29kg •Note: The stand TAD-ST2TX-K in the photo (¥280,000/pair) is sold separately •Contact: Pioneer Customer Support Center (TAD consultation desk 2) 0120-995-823

Eight years have passed since the release of the previous product, CE1, and CE1TX, an improved version of C FI, has been released. In the documentation for this machine, when describing changes (improvements) from the previous version, "evolution" is referred to as "deepening." This is probably a statement from the research and development team.

The unit stands straight on its special stand.

The enclosure has a beautiful wood finish wrapped in a single layer of veneer from front to back. Sandwiched between 10mm-thick aluminum side panels for the company's unique bass enhancement method (bidirectional ADS port), it looks slimmer and cleaner than its predecessor (the internal volume remains unchanged). Reinforcement has become stronger. The 18cm woofer cone has a 5-layer structure that was created through 6 to 7 different prototypes, and has been optimized for high rigidity and vibration damping. Initial sensitivity can be increased. Improved linearity.

CST covers pressures from 250 yen to 100k (covers a wide band of 6 octaves in the audible range)

(Coherent Source Transducer)

The driver has a coaxial structure for the midrange and tweeter, which improves three-dimensional sound field expression, allowing for both the sound field and the sound image to be balanced in different dimensions.



In the TX, the back of the midrange part of the CST diaphragm is Achieved a 10% weight reduction by removing the anti-tear mark. Furthermore, the voice coil was moved by 0.3mm to increase the driving force. By improving symmetry, harmonic distortion reduction and line (It said that they are trying to improve the quality and characteristics).

This is a major point in the development date for this machine, which refers to... The curve of the magnesium midrange cone, even the outermost ring shape of the CST driver, has been carefully designed to seamlessly direct the sound radiation from the beryllium tweeter dome and smoothly connect it to the midrange. Designed. With this TX version, the midrange cone is approximately 10% lighter. It is said that

is the T in Technical, so the sound field is sharp, and the sound image has a three-dimensional feel that Being a technology-driven speaker manufacturer become. In fact, is there any other manufacturer that measures, analyzes, and researches speakers as thoroughly as Ding AD? What deepened this feeling was the story of how, when the CST driver used in the previous product was mass-produced, it was discovered that the position of the voice coil was off by 0.3 mm, which was different from the design. In this TX version By correcting the force coefficient of the magnetic circuit.

Optimized to reduce next-order distortion in the midrange.

The sound has no unpleasant taste, strong harshness, or dirt. Its smooth, clean, transparent, and glossy appearance is breathtakingly beautiful. There are no rumbling sounds around the statue. The silence in the background of the music is exceptional, and it's completely silent. The delicacy and suppleness of the long echoes are outstanding, and the atmosphere of the space where the recording was made is felt. The T in Sumi TAD you can almost touch. A panorama of music spreads out between the left and right units.

The elastic and rhythmic bass range is exactly the sort of bass you can't hear with other speakers. Given the size of the enclosure, I could feel the incredibly low wind pressure. I tried listening to it on the special stand, and it is a must-have item. In fact, the dedicated stand usage rate in the previous game is said to be over 80%.



The separately sold stand has also been redesigned, saving support and stability in order to achieve low-temperature regeneration. The base part is equipped with Increased strength using 5mm steel plate and MDF. This results in a lower center of gravity and higher rigidity. The pillar is The trapezoidal structure makes it look more stylish. The University of Technology (assigned to)

A new small speaker is added to Audel, which features a birch laminate enclosure.

Good and fulfilling playback. organic sound

speaker system

Hiroji Onodera



Audel U-Basik 5/8 ¥390,000(pair)

- Model: 2-way 2-speaker bass reflex type •Units used: Woofer, 13cm cone type, tweeter, 2.9cm dome type •Crossover frequency: 2.5kHz Sensitivity: 88.5dB/2.83V/m •Impedance: 40 •Dimensions, Weight: W220 x H350 x D210mm 7.5kg
- Note: The finish in the photo is walnut. Art finish (¥430,000/pair) is available for an additional price, exclusive to the photo.
- Stand U-Tripod (¥160,000/pair) and grill cover (¥30,000/pair) are sold separately •Contact Stella Co., Ltd. ☎03 (3958)9333

Speakers	Digital Components	Amplifier	Analog Components	Other Components
----------	--------------------	-----------	-------------------	------------------

Audel is a company based in Sicily, Italy. It features a unique speaker system with unique design and structure. The importer of Audel has changed, and I had the opportunity to listen to the small system "U-Basik 5/8." This is also a very distinctive speaker system made by the same company. The numbers in the model number are said to indicate the diameter of the woofer unit in the front, and the internal volume of the enclosure (8 liters) in the latter. The installed unit is manufactured by SR Acoustics. The woofer As mentioned above, the unit has a cone shape with a diameter of 5 inches (13 cm), and the tweeter is a soft dome shape with a diameter of 2.9 cm. It may look like an ordinary unit, but as we will explain later, its capabilities cannot be underestimated. High-end models use beryllium diaphragms in the Takagi unit, but it goes without saying that the choice will differ depending on the development goal.

Audel's most distinctive feature is its enclosure. First, we used laminated birch material, which has excellent acoustic properties. This is the iconic style of the company's speakers, and is a common feature from high-end models to entry-level models like this one. The enclosure is then formed by pasting these laminates back and forth. In other words, if you cut out the center of the board

The rollers overlap to form a cavity, and this is more effective than a normal enclosure, where each of the six sides of the box is formed by a single board. It's a time-consuming method.

However, by adopting this method, it is possible to create a step inside the enclosure by changing the volume of each hollowed out piece, which increases the rigidity of the rib structure and eliminates internal standing waves. This means that there will be benefits. Furthermore, there are two enclosures in the front and back made of birch laminate. By interposing FEN 1X material called next-generation acrylic in the middle, it has achieved excellent vibration reduction and characteristics. All enclosure processing is done in-house in white, with adhesive bonding, surface polishing, and a beeswax finish. Ru.

The dedicated stand sold separately is also from the same company.

It has a nice design and looks like a chair. It has a three-leg structure made of high-quality wood, and when used on the floor, although it is expensive, it is definitely worth using together. I tested it on this stand, but this unit also works well even when placed on something like a bookshelf (wooden shelf) for the first time. You should enjoy it to the fullest.

I'm not greedy for playback bandwidth, but it's extremely rich in both surprised and impressed by the quality and richness of the re-created sounds. At a time when products that make full use of high-tech materials are at their peak, sounds like this, which are simple and organic in a good way, are precious. The bass also produces a good sense of volume so you don't feel like it's lacking, and the musical resolution is high. The lustrous warmth reminiscent of human skin and the joy of singing well will make you wonder what else is needed for music playback. There is a pause.

The rear baffle is firmly fixed with bolts. The terminal is for single wiring.



Looking at the side, you can clearly see that the plain enclosure is made of birch laminate. You can clearly see that the back material between the birch laminates is the next-generation acrylic material "FEN1X" and by sandwiching it between them, the cabinet and special stand have vibration damping properties that could not be achieved with birch laminates alone. The front two points are spiked, but the back one is fixed with a screw to prevent it from falling.

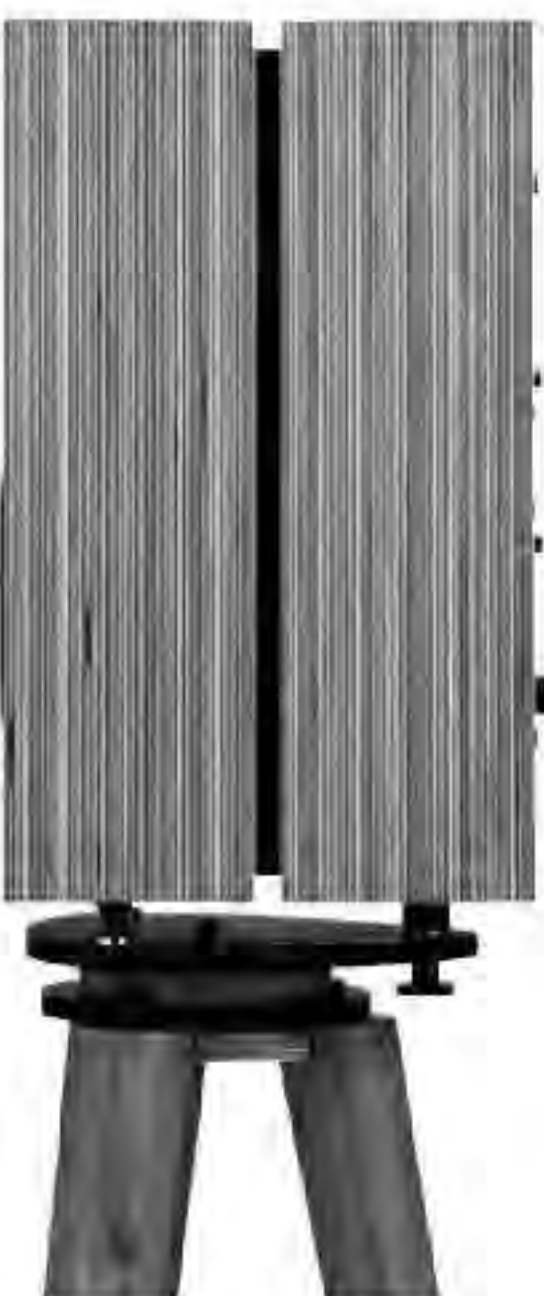

Grand series SACD/network player becomes M2 with introduction of new technology

SACD/CD player

Actively bring out the atmosphere and temperature of the live performance

Tadashi Yamanouchi



be limited to mid-range and above. is still extremely high, and it may

The development pace of disc players

playback are expected to emerge. Especially domestic manufacturers are disc fans. High-performance models that support D and high-resolution file G700, is enthusiastic about its development, and has strong support from which has played an important role in the development of the SL-G700. G700 is the first model change in three years for the 700. Technics, It has been reborn as M2 and has evolved. The SL-

The appearance and structure of mechanical parts are unchanged from the previous generation. In

of all, what has evolved at the heart of the ESS?

ESS has a lower DAC chip than the conventional AK4497. First sound quality. "It is said that almost all of the and we added optical technology to improve the refers to the characteristics of phase and amplitude, is manually operated. "Nont" is a physics term that occur in the digital low-pass filter at the stage before the DAC measure the phase and amplitude disturbances that pass filter. It is often used in academia and acoustics to process cancels out the deviation by using a digital low-up the settings menu and turning it on and off.) This quickly see what kind of effect it will have by calling reached. Coherent processing is based on DSD, so you can can be determined by ear when the upper limit is This does not apply to CD or PCM file playback (which

Technics SL-G700M2 ¥370,000 (tax included)

- Available discs: SACD stereo, CD, etc. - Analog output: 1 unbalanced (RCA), 1 balanced (XLR) - Digital (excluding SACD): 1 coaxial Yun (RCA), 1 optical system (TOS) • Digital input: 1 optical system (RCA), 1 optical system (TOS), 3 USB systems (A type x 2: PCM ~384kHz/32 bit, DSD ~11.2MHz, B type: PCM ~384kHz/32 bit, DSD ~11.2MHz), 1 Ethernet system (RJ45) • Dimensions Weight: W430 x H98 x D407mm//12.3kg • Note: The finish in the photo is silver, others are available in black, Wi-Fi, Bluetooth • Contact: Panasonic Customer Service Center 0120-878-982



In addition to the conventional optical, coaxial, and Ethernet (RJ45) digital input terminals, a new USB-B compatible with PCM-384kHz/32 bits and DSD-11.2MHz has been added, and the analog output terminals are balanced. Equipped with one unbalanced system each.



The internal layout has a power supply section on the left, a disk drive and digital input section in the center, and an analog circuit on the right. The current section continues to use a switching power supply as in previous models, but the switching frequency has been changed from 100kHz. The speed has been increased to 300kHz. The DAC chip is an 8ch specification ES9026PRO with mono operation and L/R independent, and the low-pass filter is a discrete configuration.



of SU-R1000) for the power supply circuit.

352.8/384k, which was obtained during the development to 300K to make the noise audible, significantly reducing noise. (Excluding we have also increased the reverse-phase electrical charging frequency feed-forward type noise canceling range that cancels it out using the USB flow, of functionality, in addition to pushing the residual noise out of the all of the SL-G700's selling circuits have been newly introduced. In terms for some reason the new PA-B input caught my attention. Almost to a computer via USB. Imagawa's digital sound sources were covered, but is turned on when playing a CD. Since it was not possible to connect will be pleased with the enhanced functionality of when coherent processing

which improves the image of the instrument. I'm sure many listeners stage is deepened. The focus of voices and solo instruments is improved, three-dimensional effect of chamber music is improved, and the perspective of the

We can mainly see an improvement in the accuracy of spatial reproduction. The

A sound source with a wealth of acoustic information such as music and vocal music.

It is easier to understand, but the guitar and vocals etc.

If it's a simple song, it should be easy to hear the effect.

orchestral music you listen to is based on a simple band balance.

and arte were improved while carrying over from the original SACD. The characteristics of Noculation were taken a step further, and the phrasing

temperature, adding a sense of undulation and humanity to the facial expressions. The

jazz recordings began to capture the heightened atmosphere and sense of the bass line, and the vocals that can be heard when playing the file. Live

out the outstanding persuasive power of the breathing and undulation of

about by changing the DAC and introducing new technology actively bring

time, we tried to revitalize the sound by including these. The changes brought think they were aware of this when developing it. If so, it's not small. This

If so, the results are as expected. |

A 300B push-pull amplifier that uses a cirrotron circuit and is a 50th anniversary model.

Power Amplifier

Natural and neutral. Has high speaker driving power

Kenji Mayuzumi

Listen to this power amp

of 300B had never been heard before. was wrong with Ayumu, but the sound of being unknown. I was wondering what singles full of singles and I was ashamed Fujiwara, and the upper 300B parallel 300B sound is on a different level from establishment of Sugi Research Institute, the second generation. 50 years since the is responsible for the development of the over the business as an expert. Mr. Nobuo new heights in 10 years. Mr. Nobuo look The spirit of Sugi amplifiers has reached You can say that.

this result was also achieved. circuit. Although there are several factors, output circuit in 2014 is the the adoption of the U/B Rotron The most important aspect of ros120 (KT120) First adopted in PP), U.B. (12AX7), TAP105 (2020), TAP105 (2020) Created by EL34PP One Tube King Country" My Handicraft

Improve performance by improving the circuit configuration (published model) and circuit configuration.

transformer has been a major advantage. However, the simple structure of the bound by the design methods of amplifiers, and high sound quality without being breakthrough in achieving high performance model name (Alternate) has become a (current heating). In addition, the AH current through a low-pass filter heated triode is ignited by an alternating wooden machines. The filament of a direct- This is one of the characteristics of based on Western Encortic's genuine 300. reprint started, and this amp's registration is to back up the plant. In 2018, the U.S. B A new factory was built in Rosssvenor, Georgia

We are committed to producing products using modernized production lines. would have remained stable in recent years (according to Mr. Fujiwara). it means. Without the existence of these vacuum tubes, the quality the amplifier would have been commercialized. That's what While listening to the U.Bros330AH, I doubt that ME1000, a 1 kg monaural machine, during his time at Victor. 1991 after thinking about the monumental 300 pump domestically produced power machine, completed it in there was. Mr. Fujiwara, the developer of the

Wooden U· Bros 330AHWE ¥2,100,000 (pair)

•Output: 30W (160, 80, 40) •Input sensitivity/impedance: 1V/30kΩ Vacuum tubes used: 12AX7A×1, 6CG7×1, 12AT7×2, WE300B×2 •Dimensions/Weight: W364×H201×D218mm 17.5kg •Note: Photos and prices are for output tubes made by WE (Western Electric). In addition, the output tubes are PSVANE's "U· Bros 330AHPs (¥1,850,000· pair)", 4, and "U· Bros 330AHL" without power tubes. (¥1,650,000/pair) available, vacuum tube cover optional

(Details are on page 462) •Inquiries: Uesugi Research Institute Yokohama Office 044(712)4632



Supports speaker outputs of 160, 80, and 40. The input terminals are unbalanced only, and in addition to direct, there is also a normal terminal with the volume connected in parallel. In addition to the volume control, the front panel (bottom left side of the photo) has a function selector switch for the front panel pointer meter.

By using the included screwdriver, you can adjust the hum level as well as the output tube's plate current and plate unbalance current while watching the meter.



Remove the bottom plate and look inside. Of the four choke coils on the left, the two on the far left of the photo are the filters for 300B AC ignition, and the two next to them are the positive cycle of the output stage, which is essential for the circrotron circuit. For negative cycle B power supply. The bias circuit and protection circuit are mounted on the lower right board.

Backed by the power of W

Overwhelming speaker driving power something strange about it. Useless self-assertion, there is is cool, and while he has a sound. Mr. Fujiwara's personality that you can feel from the one. The ME1000 is a product amplification element was the conductors to vacuum tubes. The since amplifiers changed from engineer. It has been 30 years his 50-year career as an audio was completed as a culmination of Fujiwara's audio design, which This is the culmination of Mr.

It's a power amp. It

operates with this unit already has a 300B single. monaural power amplifier U/Bro Uesugi that different from those singles, but the circrotron circuit and has a sound that is definitely If that does not have a Class AB operation Uesugi, could not have achieved. There is a \$300/300A machine, reaches a height of sound that the founder, Uesugi that you'd almost want to call it a special female vocalist who was so loved by Yoshiro Sakar The 300B single by Uesugi, a bewitching reproduces a natural or rich sound, but the 300B with high speaker drive ability. The Crotron 330AH it has a neutral, neat, and well-controlled sound it is at the cutting edge of the modern audio scene, was finished as a power amplifier. Although

Esoteric class A power amplifier that outputs 60W per channel.

Faithful reproduction with little coloring. high heat sound

Power Amplifier

Tadashi Yamanouchi

SO Uha, entry in Esoteric's power amplifiers.

Although it is positioned as a high-end model, there are many points that need to be improved in terms of technology and functionality, and it is not simply a scaled-down version of a higher-end model. First, we adopted a class A amplifier to ensure a high quality sound, and while it outputs 60W (1C) per channel, it provides a powerful sound that can be used to drive human-shaped speakers by giving the power supply section an excessive amount of leeway. The big thing is that it was aimed at

Another important point when aiming for a spacious sound is that it is compatible with Esoteric's proprietary current transmission method "ES-Link analog output. For example, it supports ES-Link analog output such as the company's preamplifier and NOS By combining it with equipment, you can take advantage of the advantages of cardiac flow transmission, which accurately transmits even the smallest signals. By the way, if you switch to current transmission, the amount of current for the same pitch is approximately 100 times higher, and there is no need to consider cable loss. In addition, to avoid incorrect connections, connect the XLR cable to the dedicated terminal in the opposite direction than usual, and operate the pre- and power-1 sides normally. The transmission and switching method is followed from the higher-end models. Although there are no safety concerns, I was concerned about the fact that the input selector on the back panel moved easily. Stereo/BTL/ Toggle bi-amping The same goes for the output mode switch.

The power transformer is an F-1 type with a capacity of 940 days, and is placed in the front center using a bare mount method rather than being housed in a case.

Esoteric S05 ¥900,000

•Output: 30W+30W (8Ω), 60W+60W(4Ω), 120W (8Ω when connected to BTL) •Input sensitivity Impedance: 580mV/100k Dimensions/Weight: W445 x H191 x D444mm/ 30.7kg•Note: True finish is silver, black (Y920,000) available for an additional price•Inquiry Address: Esoteric Stock AV Customer Service Office 042 (356)9235



It has an input terminal in the upper center and speaker terminals on both sides. In addition to one unbalanced and one balanced input terminal, Esoteric's original current transmission method, ESL-A (ES-Link analog), is also equipped. At the top right, in addition to the input selector, there is a stereo/BTL/bi-amp operation mode setting switch.



A power supply path consisting of a 940 VA E-core power transformer and a 10,000 μ F electrolytic capacitor (5 channels) is located in the center of the main unit. The amplifier stage has a 3-parallel push-pull configuration with class A operation. In addition to being equipped with a temperature compensation circuit to suppress operating fluctuations due to temperature, the parts layout has been optimized.

Separation has been improved by thoroughly implementing a dual-mono configuration from the rectifier circuit stage, and the capacitor has also been configured in a dual-mono parallel configuration to ensure current supply capability. The Kawa Riki stage has a 3-parallel push-pull configuration of bipolar transistors and a human-shaped heat shield with a special wave shape to reduce resonance. **It is combined with a link.**

I paired it with the NOS5XD in Esoteric's listening room and confirmed the playback sound using both normal transmission and current transmission methods. Both of them have a low center of gravity, band balance, and quick response, and in a human orchestra, they can draw powerful tutti from the 800D3. Switching to current transmission has many benefits, such as increasing the sense of perspective on the stage and the volume of mid- and low-frequency sounds, and finely distinguishing the gradations in soft tones in songs with lute accompaniment.

However, specific changes were observed. The tones of voices and solo instruments do not change due to the difference in transmission method, and regardless of which connection method is used, the timbre is faithfully reproduced with very little coloration. Monheit's vocals have a mid-low range body. It realistically reproduced the soft feel of the sound and high frequencies, and I was also impressed by the breadth of emotional expression. Horn instruments do not lose their sound in any range, and moreover, they can bring out the force and instantaneous power of the sound without hesitation, and the overall sound is quite energetic. The texture of voices and the density of horn instruments can be said to be the strengths of class A amplifiers, can be Although it's not an amp that flaunts its extra power, I was able to enjoy the unique appeal of this unit, which is different from higher-end models.

Macintosh's large integrated system has evolved with a power supply and the latest digital module.

brimain amplifier

A rich tone with a traditional feel. Persuasive power that makes you say yes or no

Hiroji Onodera



McIntosh is a prestigious name in the amplifier world.

over its long history, a variety of excellent machines have been born. Grand Prix, but the integrated amplifier was introduced last year, and model is the super-dreadnought machine M that won the True Leo Sound configuration that incorporates the best of both worlds. This f! The A12000 is still fresh in our memory, as it features a hybrid It's a flagship machine that gives off a new generation feel. a Macintosh boot before the release of MA12000.

and majestic Remain Amplifier is the MA9000. This is only of semiconductors, but the flagship of the human-shaped and it is also full of Macintosh characteristics. It was composed powerful models. The wooden machine MA9500 is a barrel, up, and the basic functions and configuration were improved models of the MA9000, with various parts brushed looked exactly the same and were similar to the MA9000, and were without looking at the Dell number display? The two machines it impossible to determine which one is the new product Is it? Isn't

The basic structure is as follows.

in the impedance of the speaker. important feature is that a lance is installed situation. For this reason, the extremely high output regardless of the It is possible to stably and safely supply 's reliability is something you can't expect from other brands.

Macintosh MA9500 ¥1,740,000

•Output: 300W+300W (30,40,20) •Input sensitivity Impedance: 0.3mV 500~1k Ω (Fano/MC), 3mV/47K Ω (phono/MM), 300mV//22k Ω (unbalanced), 600mV/44k Ω (balanced) •Digital input: 2 coaxial lines (RCA), 2 optical system (TOS), 1 USB system (B type: PCM/~384kHz/32 bit, DSD/~22.4MHz), 1 HDMI system (ARC), 1 MCT - Dimensions, weight: W445 x H240 x D502mm/45.8kg - Inquiry: Stock Electric ☎03 (5419)1594



by increasing the filter capacitor in the power supply section.

drive ability is improved by increasing the capacity. This is achieved
That is. The

terms of functions, it has a wide range of frequencies with 8 bands. Po
equalizer that allows you to control the characteristics with the int. In
adjusted according to the music source and listening environment. An
importance. Also worth mentioning is the provision of tone controls that can be
These functions that can be finished in the desired tone are given more
it's okay to be treated like that.

A rich color that makes you feel the tradition of Macintosh.
listen. The charm of the tone stands out. Massive, powerful and tight
ordinary sound has a persuasive power that makes you want to

listening to, and although it's rich, it certainly doesn't overshadow the details, and the
and the visibility of the sound field is good. It's a magnificent sound that's worth
It has a presence that will blow away a bad separate amp. There are a lot of them,

Speakers	Digital Components	Amplifier	Analog Components	Other Components
----------	--------------------	-----------	-------------------	------------------

The proof is that it is equipped with three systems.
has a rich set of functions and can also be compatible
The phono system has one system each for MC/MM. It
USB/HDMI inputs, and 6 unbalanced/2 balanced lines.
monologue standard, 2 coaxial/2 optical/1
1/MCTI line input according to the company's
unlikely to occur. Digital inputs are lacking, such as (ARC)
digital files. It is equipped with a variety of inputs that are
total harmonic rate, which are a hot topic when playing
module, which has improved dynamic range and
changed from the conventional DA1 module to the DA2
with this unit is that the digital input section has been
That's what it means. One of the key points of improvement
Don't miss it. Other improvements include:



Digital input supports PCM384kHz 32bit, DSD22.4MHz
Newly adopted DA2 DAC module equipped with USB-B and HDMI (ARC) terminals.
for. On the other hand, the analog inputs are 2 balanced human power systems, 6 unbalanced human power systems.
It also fully supports one MM/MC phono input and one analog input. Output circuit
The output terminals are 80, 40, 20, and speed
Select impedance according to the beaker.



The chassis goes up from the top, the basic layout is the previous MA9000.
The autoformer is placed on the front left side of the housing, and the power transformer is placed all over the place.
There is. The machete elements are attached to the left and right heat sinks, dissipating heat efficiently.
It is designed to be able to

Second top model of AB class integrated, with improvements mainly in the AAVA circuit and amplification stage.

primain amplifier

A lively sound pops out, as if the performer has awakened.

Kenji Mayuzumi

can feel a new breath of fresh air from this amp, and the Accuf generational change in phase sound is steadily progressing. You amplifiers. Up until now, the model number had been 3 digits. The understand the 4-digit model number for A-class integrated the 5000 was added, it was a top-end model. I now similar operation, common to Accuphase AB class amplifiers. When clearly different from the F800, which features a power stage with I was thrilled to hear such a pure and glossy sound, but it was

The E4000 also inherits that dog quality.

Please note that this is only my personal opinion.

And will the Accuphase people deny it? method, but rather a characteristic tendency for each finish. that this is not a difference in sound due to the operating JBL/K2S950 as an individual product. There is no. It may seem that 0, I can't express my preference for the sound of the may be nothing more than an amp that produces models, and while the P6100-P7300.PP

E400. I have chosen the 7500 and successive AB-class think that it has a unique sound that is common to the latest The E5000 is part of this trend, and I can't help but the sound. I think that the 0 also inherits that same sound. greatest appeal of this amp is the overwhelming freshness of the speakers? It's as if the performer has awakened. The Wow, isn't that the kind of lively sound that comes out of

Ru. The sense of dynamism is wonderful, and when I listen to it, my body suddenly feels like it's moving.



Accuphase E4000 ¥630,000

•Output: 180W-100W (80), 260W+260W (40) •Input sensitivity/impedance: 190mV 20kQ (unbalanced balance), 190mV 40k (balance) •Dimensions/Weight: W465 x H181 x D428mm/24.4kg •Notes: Various options. Two boards can be installed, digital input board DAC60 (¥90,000), analog disk input board AD50 (¥60,000), line input board LINE10 (¥8,000) available •Inquiries: Accuphase Co., Ltd.) ☎045 (901)2771



As expected from the company's integrated amplifier, it has a large number of input terminals, including 5 unbalanced input terminals and 2 balanced input terminals, recorder input/output, 1 unbalanced/balanced pre-output, and main input terminals. Be prepared. Furthermore, up to two optional boards such as a digital input board, analog disk input board, etc. can be installed.



The power supply section is located in the center, consisting of a large power transformer and two 40,000 μ F electrolytic capacitors, and the volume control mechanism AAVA in the preamplifier section has been completely revised from the previous model E480, achieving a 20% noise reduction. That's what it means. The power amplifier section has been changed from MOS-FET to a bipolar transistor similar to the E5000. The circuit configuration has also changed from the E480's 3-parallel push-pull drive to a 4-parallel push-pull drive. There is no change in the power of 180W (80) and 260W (40).



that is in rhythm with the vocals. The luster of the voice. It looks nice too, delicate nuances is three-dimensional and tight, and it is a sound fluctuations and enhance the charm of the song. The sound image with ability is also high, it helps to accurately present the subtle emotional surprised by its high drive ability in the low range. The reproduction bass. It grips the woofer firmly and produces tight bass. I am also it exquisitely reproduces loose bass and accurately depicts loose warm sound of woodwind instruments in Mt. It is also amazing how invited to the paradise... No matter what you listen to, you will hear the (2018) where you can discover new charms of songs, and you will be ability to compare the two. This unit is amplified by E180 evolution of these four works (500,000 yen), so it shows the listening to it, and it is said to be an improved version of the Accuphase I was able to confirm it again. I tried

the latest circuit configuration of higher-end models.

configuration, following the output element design and monologues. The VA is completely revised from its circuit AA is a volume adjustment mechanism for cu-phase It is probably a redesign of the power amplifier stage. The

The E480 MOS-FET-3 pair parallel loop
From push pull, bipolar transistor 1

blue parallel push-pull using the same parts (E the 5000 was changed to a 5-set parallel navy pull). In addition, due to the reduction of internal resistance, of the protective damping factor (E push-

480's DF600 to DF800), further improvement
Improvements in circuit accuracy, reduction in power consumption, etc.
It has evolved throughout the department.

Devas' debut phono equalizer for optical cartridges with an emphasis on power.

phono equalizer

Balanced energy and balance. The music's depiction of the scene is truly splendid.

Takahito Miura



DVAS LLC was just established in January of this year, a phono exclusively for optical cartridges called Model. A collizer amplifier was released. Company name DVAS (ebus) is an abbreviation for Deep Valley Audio Systems. This seems to imply that the company is an audio company based in Fukaya City (Fukaya = Deep Valley) in Saitama Prefecture. Mr. Mitsutaka Kuwabara, who is also the owner and designer, is a man who has been responsible for the image and sound quality of BD/DVD at a major electronics manufacturer. It is a genuine audio file that also appeared in the visit article in this magazine's 210 Minutes (2019).

The company, which plans to develop products with a focus on amplifiers, chose for its debut product a phono equalizer amplifier for optical cartridges, which does not have many competitors yet. Shiromi also seems to like optical cartridges and use them regularly, so it's not hard to imagine that this was the motivation for the development. DS Audio has published technical information regarding the phono equalizer circuit on the Hakusha website, and it appears that development proceeded based on that information while also reflecting the knowledge and preferences of Hakusha et al.

The full-sized case, which appears to be highly rigid, features sides that look like heat sinks. On the front are the power supply, subsonic filter, and power supply (mute) switch. The connection to the optical cartridge is via RCA terminals, and the line output is via balanced transmission via XLR terminals.

Divas Model 1 ¥1,000,000

•Phono equalizer for optical cartridge made by DS Audio •Dimensions Weight: W430×H112×D330mm,16.5kg Contact: Devas LLC 080 (7420)6494



The housing is made of seven aluminum pieces (the front panel has a main and sub-piece construction) that are firmly assembled, and the rear panel has an unbalanced input terminal for the cartridge stand-up in the center, and balanced output terminals on both sides. Deploy.



Remove the bottom plate and look inside. Each part is hung from a large board. Of the six missing transformers, two on the side of the photo (back of the maternity leave) are for bias and for the LED power supply and control circuit, and four on the side of the photo (on the front) are for the amplification stage.

↑ ↓ The Fukui board is fixed to the rear panel to shorten the signal path from the input terminals.



ing | listened

to Model 1 based on the magazine's listening rate. Attach DS Audio's new "DS-W3 | optical cartridge to Technics S L1000R and combine it with this magazine's reference equipment. It's matching.

I first listened to Anselmet's "Tricorn Hat",

The sound is thick, extends well into the low range, and has a good energy balance. The amount of information that can be said to be overwhelming is obtained from the opening section of the drums to brass instruments and castanets, and the sound of Berganza's singing voice that follows shows that clear sound is obtained down to the minute range. Donald Fagen's

"Maxine" has a powerful rhythm, and you can imagine how well equipped the power supply section is. The sound is sharp and gives the impression of a moderately toned muscular body.

Dave Grusin's "Discovered Again" on the Dainct version also has a very fresh sound, and you can clearly feel the tension of the one-shot recording. Britain's "Requiem for Command War" highlighted the depth and breadth of the sound field. This was a demonstration of the optical cartridge's excellent separation, and the depiction of the sadness and solemnity of the orchestra and mixed chorus was spectacular. It's a debut work that sounds mature and calm, with a truly authentic sound.

According to the blog published on the company website

Mr. Kuwabara places particular importance on the quality of the DC power supply that supplies the optical cartridge and the I/V conversion (fixed resistor) that converts the current from the optical cartridge into a voltage signal. All of these areas are related to the roots of sound quality, and I was satisfied that the design policy was effective in improving sound quality.

DELA's flagship aircraft undergoes a full model change. The switching hub has a new power supply section.

Music server/network attached storage switching hub

The center of gravity of the sound is lowered, and the resonance is more detailed.

Koji Yamamoto

DELA, the pioneer of audio-specific NAS, has released its flagship model, the N1 and audio switching hub S100/2.

First of all, I would like you to take a look at the N1 photo.

You'll be surprised by the impressive 440mm wide casing, which is constructed from a stainless steel chassis and aluminum plates.

Both the front and rear sides, which are toned in gray, are made of thick aluminum. The atmosphere of computer peripherals is already

It has the appearance of a full-fledged audio device. Storage is a custom 3.8 terabyte SSD. The power

supply section is a linear circuit equipped with a large-capacity toroidal transformer. The clock that runs along the time axis of this device is a highly accurate N clock.

Made by DK. Looking at the back, 2

In addition to the system LAN port, there is also an SFP port that can also perform optical transmission. The USB end is expected to be of the 2.0/3.0 type, and is also equipped with a 10 MD external clock input. Just by knowing this outline, you can tell that it was designed by a junior engineer who knows network audio. Dew.

DELA's NAS achieved a "USB1 DAC connection function" with a firmware update in late 2014, and can now be used as a network transport by using a general-purpose app, but here we will use the same sound source as a built-in SSD. I connected the TSB output to the Soul Note S3 reference and compared it with the same DELA N17 that I usually use in the magazine's listening room.

When you listen to a duo of cello and double bass, it can be seen that the new product N1 has a significantly lower center of sound, and the resonance is more detailed. When I listened to the piano concerto on N1, the orchestra was depicted three-dimensionally with great depth, and I was surprised by the difference. The piano touch is also more subtle. When you listen to male jazz vocals, you can hear the charm of N1 overflowing in the deep, lustrous voice.

N1-S38-J (photo right) ¥1,200,000

•Model: Network Attached Storage (NAS) •I/O terminals: 3 Ethernet lines (RJ45 x 2, SFP x 1), USB 5 systems (3.0 x 4, A type, 2.0 x 1, A type) Built-in storage: SSD-3.8TB
Clock included: 1 system (BNC, 10MHz) Dimensions and weight: W440 x H82 x D353mm/approx. 14kg



On the rear of the N1, the USB-A port is made by Amphenol, the RJ45 port is made by Neutrik, and the big point is that it is newly equipped with an SFP boat and a 10MHz clock.. There are two types of terminals that connect to the USB-DAC: USB2.0 and USB3.0. The other two USB-A terminals are for external storage and backup (both USB 3.0).



Inside N1. The power supply uses a Denhama transformer with a larger capacity than the N10, and a newly developed electrolytic capacitor. The humanoid main board is equipped with an NDK ultra low jitter clock. The chassis is made of 3mm thick stainless steel, and the corners and top plate are made of aluminum.



(1Gbps) There are 8 ports (one of which is used exclusively with SFP).

The number of rear ports on the S100/2 remains the same, but the number of 100Mbps ports has been reduced from 4 to 2, while the 1000Mbps port has been reduced from 4 to 2.

(making it easier to use and more convenient)

I can clearly understand that. Digital an S,NA that stores data sound sources. advantage of the USB power and is considered **expensive product that takes** thought of as a transport, but it is an extremely **network with built-in storage that is** experience the quality of this sound. It is a If anyone agrees with the price, they can I think it will be done. the previous model S Switching hub S been changed from the 100. 100/2 is been brushed up. The power circuit has and S100 The second generation has Substitute machine. General-purpose hub

experienced the dramatic improvement in sound quality. previous model from Sokko, compared his interests and **I went to The author, who purchased the** to be more precise, the sound quality is not that different. **orchestra in the description of the sound stage, but** in the silence and a three-dimensional impression of the purpose switching hubs. There is a slight sense of depth **impression that the S100/2 is superior to general-** install this unit as soon as possible, but I still have the around communication equipment, you should definitely **network audio. If you are trying to reduce noise** is realizing that it is the key to achieving high quality be it. The key to achieving high quality network audio **That would**

DELA \$100/2-C-J(

Photo left) ¥152,728

•Input/output terminal completion: 10 Ethernet systems (RJ45-100Mbps x 2, RJ45-1000Mbps x 6, SFP x 2) •Dimensions and weight: W215 x H61 x D270mm/approx. 2.5kg •Notes: The finish in the photo is silver, others Black (S100/2-CB-J) available. One of the SFP ports is used exclusively as a 1000Mbps port. SFP module available as an option •Contact: Stock Buffalo Support Center 0570 (086)086

Spendor's "A-line" has arrived in Japan. The first is a 2-way floor standing machine.

speaker system

Traditional British sound with a modern wide range feel

Koji Yamamoto



Available in

four finishes:

oak, black oak,

walnut, and satin

white. The

listening machine

was made of plain

oak and had a

very nice

atmosphere. It would

look great in a

beige living room.

This unit has

a low height

of 386 cm, and

is often used in

listening rooms.

Noble tone with no sharp edges. If you

raise the output too high, the tweeter will

scream, but if you listen with common sense,

the tone is extremely well-balanced and

moderate. You could say it's a traditional British

sound with a modern wide-range feel. Paul

Lewis' performance of Beethoven's

Piano Concerto No. 5, "Emperor," second

movement, was amazing. The tone is calm

and calm, as if a piano were highlighted

under a spotlight with low illuminance and

color temperature, and the orchestral sound

with a faint sheen is rich, deep, and three-

dimensional. I listened to Yoshitaka Minami's

"7th Avenue South" on analog, and the

vocals were very expressive. The undulating

bass has a high resolution, and I can clearly

see that they have added a modern touch to the

taste of a long-established brand with a

long history. Although it is not the type of

speaker that requires much effort to use, it

is recommended to use it with the grill attached

for living room use, as the tone feels

more well-balanced and calms when you listen

to it. I want to.

The A series is the entry line from

Gespendor, a long-established British speaker.

The A4 introduced here is the second

model in this series, and is a 2-way bass reflex

(rear port) floorstanding speaker. The

woofer is an 18cm polymer cone, and the

tweeter is a 2mm soft dome, a configuration

typical of the British brand.

When you sit on the bench chair, you listen to music

as if you were looking down at the speakers. Some

people may say that this style is good, but I felt

uncomfortable with the sound image and sound field expression.

So I decided to listen while sitting directly on the

floor. This way, my ears (I sit at a high height) and

the tweeter position are almost in line, and the sound

image localization feels good.

Spendor A4 ¥440,000 (pair)

•Model: 2-way 2-speaker bass reflex type •Unit used: Woofer, 18cm cone type, tweeter
 -2.2cm dome type Crossover frequency: 3.7kHz Sensitivity: 86dB/W/m •Impedance: 8
 Ω •Dimensions/Weight: W165 x H861 x D284mm 14.5kg •Note: The finish shown in the photo is oak, and others are black.
 Available in rack oak, walnut, and satin white •Inquiries: Triode Co., Ltd. ☎048(940) 3852

Krypton's KX3 changes internal wiring and finish to evolve into 6th generation "SX"

speaker system

Clear bass. Excellent expression of vocal nuances

Koji Yamamoto

Both the eater and woofer/tweeter have a sealed 2-way configuration with internal magnetic circuits using alnico magnets. This is the basic concept of the KX3 series. This time is no different. So what has changed? One is the external frame. Although the device supports bi-wiring and input, I first listened to it with a single connection. A sturdy jumper cable connects the low frequency/high frequency input. I like that it's not a cheap metal bar that is often made overseas. Although the sound is modest, it has a clear bass tone that makes it easy to understand the scale of the bass. In addition, the linearity of the midrange is probably excellent, and the expression of vocal nuances is extremely skillful.

When bi-wired, the mid-high range increased clarity and clearer sound

To. The slight roughness in the vocal band that was noticeable when using a single connection also disappeared. The wooden machine uses a long voice coil with edgewise four-layer winding in the woofer's magnetic circuit (most home speakers have two layers). Therefore, the back electromotive force is large, and the benefits of bi-wiring connections are probably great.

In any case, the high resolution and excellent transient sound that can only be expected from a closed-back speaker is unique among speakers of the same manufacturer. It's a speaker whose expression changes surprisingly depending on the amp selection and settings, so it's a gem that veteran audiophiles will want to use carefully.



Japan's proud speaker, Acrypton, has undergone a model change and is now available under the model name

KX3SX. This SX version is the 6th generation KX3 model.

15cm so-called Rokuhan (6-inch) woofer with Kurt Muller pulp cone, ring toe with bullet-shaped equalizer

Nonish is now available in Thursday's beautiful Wonder

Rose veneer polyester finish. As for the internal wiring material, the company has optimized the use of PC Triple

C wire, which is sold separately, for the woofer and tweeter. Especially these two points. In addition, the

amount and placement of sound-absorbing materials are being reconsidered in conjunction with changes to internal wiring materials.

Krypton KX3SX ¥398,000(hair)

•Model: 2-way 2-speaker sealed type •Unit used: Woofer 17cm cone type, tweeter 3.5cm re
•Crossover frequency: 3.5kHz Sensitivity: 87dB/W/m•Impedance: 60•Dimensions/Weight:
W224×H380×D319mm/10.8kg•Note: The speaker stand in the photo "SD5_ (Y70,000/pair) is not included.
Sales Contact: Krypton Co., Ltd. Audio Division 03(3353)5017

A full-size CD player supervised by Fundamental that matches the N-Mode pre-main.

CD player

Wide range sound. The crisp tone is refreshing

Koji Yamamoto



I immediately recognized Nummo, which has a reputation for 1-bit amplifiers. The CD player X-CD5 was released by Makoto as if by a ruler. It has a full component size thin design and the same proportions as the company's X-PM5 integrated amplifier. It is likely that a combination of both models is envisaged. The finish is silver and black.

The design of this unit was supervised by Mr. Satoshi Suzuki of Fundamental, a leading figure in the high-end audio world. The team focused on optimizing the ground and lowering the impedance of the circuit. DAC elements are expensive. The highest grade stereo grade ESS903 8Q2M from ESS Technology, which is proud of its current power. In terms of functionality, the fact that it supports MQA/CD is likely to be a popular topic. Not only is it equipped with a digital power supply (coaxial system) to shut down the power supply to analog circuits, it is also compatible with external clock input. The standard is flat legs, but three spikes are the same. It is also interesting that the sound quality can be tuned using the foot.

I started listening to it with a standard flat foot, and found it to be a really good-sounding CD player.

The impression is that it accurately expresses the dynamism of music with a straight wide range sound. The crisp tone is refreshing. After listening to it for a while, I attached the included three-point spike foot. The mounting positions are 2 on the left side and 1 on the right side, rather than the usual 2 on the front and 1 on the rear. left Is it because the power transformer is located on the side? The sound quality improvement effect of this foot replacement was remarkable. John Zorn's "New Masada Quartet" has an even greater sense of energy, and the slight bass smear that was noticeable when playing in half-leg mode has disappeared, and the sound has become clearer. It became a sound.

I listened to Tatsuro Yamashita's ballad "Storm" from his 1979 work "Moonglow," and this performance was also excellent. The combination of Shuichi Murakami Ponta's lyrical drumming and bass is depicted in such detail that it looks like daylight, and the strings spread out three-dimensionally. Tatsuro's youthfulness

I also take my hat off to the lustrous quality of her singing voice.

Although the CD player does not have an SACD playback function or USB-DAC function, I bought it because of the good sound.

"I want to!" and "I want to."

Nmode X-CD5 ¥220,000

•Playable disc: CD •Analog output: 1 unbalanced system (RCA), •Digital output Power: 1 coaxial line (RCA), 1 line (TOS) •Clock input: 1 coaxial line (BNC, 44.1kHz~49.152MHz) Dimensions, weight: W420 x H73 x D237mm/4.8kg ●
The true finish is black, and silver is also available •Inquiries: Kabu Lyric ☎092 (403) 1003

Denon's mid-sized SACD/CD player has been completely redesigned with advanced parts.

SACD/CD player

Gorgeous sound that is full of dynamism and is worth listening to

Kenji Mayuzumi

I remember very well when I first heard this product. I'll never forget the smile on my face as sound master Shinichi Yamauchi happily brought the device into the Denon listening room in Kawasaki, saying, "It's finally here." This SACD/CD player is probably a product that Mr. Yamauchi has a lot of feelings for.

As the lower stage of music provision is changing from packaged media to distribution, it is becoming difficult for Denon, which supplies products to the global market, to call digital disc players a core product. It is speculated that amid such headwinds, the new generation of Based on the DCD1600NE (released in 2016), which was developed as a player (according to Mr. Yamauchi), we incorporated the results of the DCD-A110, Denon's 110th anniversary model, to determine how far the performance of the digital denon player can be improved. This device was developed aggressively by Sound Master's Mr. Yamauchi and the Denon engineering team. Repeated thorough auditions,

Sound quality was examined in depth and in detail, and a variety of measures were put in place to bring Denon's development milestones and Mr. Yamauchi's "Vivid & Spacious" to life. This is a product that takes full advantage of Mr. Yamauchi's experience, skills, and honed sensibility, which he has deepened over the seven years he has been in the position of Sound Master. In terms of content, the history of changes in important parts related to sound quality was covered in more than 80 locations. For example, the operational amplifier uses high-quality sound components manufactured by TI that are of a higher grade (=more expensive) than the DCD1600NE. It is said that the high-grade capacitors developed for the Limited Series are generously installed in various locations.

Perhaps as a result of this, you can enjoy crisp, vibrant sound, and the gorgeous sound is reminiscent of the 110 series. The image is that the air that fills the sound field is cool, but the temperature is not too low, and the music is quiet but colorful and vibrant in a comfortable space with just the right amount of humidity. It can also be described as a rich, deep-tasting sound.

The DCD-700NE is a popular-class product for Denon, but it is a well-thought-out, I enjoyed the high-quality sound.

Denon DCD1700NE Price undetermined (scheduled to be around ¥200,000)

- Available discs: SACD stereo, CD, etc. - Analog output: Unbalanced 1 thread
Digital output (excluding SACD): 1 coaxial line (RCA), 1 optical line (TOS)

•Dimensions/Weight: W434 x H135 x D384mm 9kg •Note: This machine will be released in spring 2023

Scheduled to be released around 2020 •Inquiries: D&M Customer Consultation Center 0570 (666)112

Lumin's flagship digital file transport upgrades its power supply to become "X"

digital file transport

Improved sharpness and realism. Propulsion is outstanding

Tadashi Yamamoto



Roon's U1X is a power supply unit for UI.

It is the latest network transport with enhanced features. Although it is ranked at the top of the company's transport range, it has been significantly upgraded by adopting the power supply unit of the network player's flagship model, the X1. This product is a strong candidate if you want to enjoy network playback with a level of usability that is different from that of a personal computer, assuming that you can use your own D/A converter. Although it is originally Roon Ready, it can also be used in Roon Only mode by changing the settings from the app, so it is worth checking out for those who want to maximize Roon's low-pitched sound quality.

The supported file formats and main functions are the same as the lower model U2mini, and the easy-to-use operation app can be used on this unit as well. In addition to USB, it has optical, coaxial (RCA/BNC), and AES/EBU connections for external DACs, and when outputting via USB, it supports a wide range of PCM up to 768kb/3232 bits and DSD up to 2-4M balls. Multi-stream MQA signal output mode

You can switch between core decoded digital output and pass-through output using U1X according to the specifications of the connected DAC from the app.

Connect the U1X to the reference system in the magazine's listening room, and use the Accuphase DC I checked the internal work by connecting it to the 1000 via USB. The use of power supplies often leads to expanded dynamic range and improved instantaneous power, and the C1X is no exception. Compared to the previous listening experience, in orchestral works, the absolute amount of air moved by the bass instruments becomes larger, and the reach of the lingering sound that spreads after the bass is released becomes one step deeper. Furthermore, in works with large orchestrations, the sense of sound pressure increases at the maximum volume reached at the crescendo, the energy of the fundamental chord of the bass instrument is enriched, and the scale of the chords expands.

Let me also introduce the effects of switching from normal-Roon playback to Roon Only mode. In "The Berlin Philharmonic's March of an Empire," the instruments that play the rhythm have improved sharpness and realism while maintaining a low center of gravity and band balance, moving toward a direction in which the propulsive force becomes more prominent. This is a bigger change than expected.

Lumin U1X ¥1,331,000

•Digital input: 1 Ethernet line (RJ45) •Digital output: 2 coaxial lines (RCA, BNC), 1 balanced line (XLR), 1 optical line (TOS), 2 USB systems (A type) •Supported file formats: DSF, DFF, AIFF, ALAC, FLAC, WAV, etc. •Supported sampling frequencies: PCM - 768kHz/32bit, DSD/~22.4MHz Dimensions/Weight: Main unit: W350 x H60 x D345mm 8kg, power supply section: W106 x H60 x D334mm 4kg•Note: The finish in the photo is black, but silver is available at a separate price (¥1,210,000)•Inquiries: Brighttone ☎050 (6877)6043

Electrocompanier's digital file player with built-in storage

digital file player

Powerful sound that paints a vivid sound image

Koji Yamamoto

A network audio player from Norwegian high-end audio brand Electrocompanier. It is a thin type with full component size, and the acrylic plate attached to the front panel gives off the manufacturer's unique flair. It seems to use two Cirrus Logic DAC elements and operate with monaural specifications for each of L and R.

Dedicated operation app "EC Play" is available for Spotify and TIDAL

You can enjoy flat-rate streaming services such as AL and Qobuz (Practical high-resolution distribution in LAC files), which has been announced to start service in Japan. It is also a Room Ready device and supports wireless playback such as Bluetooth and Airplay.

External storage sound using LAN Of course, Raku File's Nyu is also possible. (PCM192K/Mbit, up to DSD 5.6M), interestingly this machine 2/5/3/5 inch SSD inside.

The idea is to have a space where you can build in an HDD. has been done.

I listened to my favorite high-resolution files stored in DELA's N1Z in the magazine's listening room and tried playing them on this unit. I expected a delicate and clean tone based on the appearance, but the result was more than I expected. The sound is full of power and powerfully depicts the sound image. Of course, I'm not dissatisfied with the wide range of expressions that can only be expected from high-resolution, and the clear sound of the piano is also beautifully depicted, but when listening to a duo such as a cello and contrabass, what is brought to the foreground in the auditory sense is the weight of the thick-core double bass or the reality of the rich sound image of the cello.

Gregory of CD spec at TIDAL

When I listened to Porter's vocal album, I couldn't help but fall in love with his strong, solid, manly voice. Michael Jackson's "Bad" sung a cappella by The Real Group, a mixed Swedish chorus, is a great listen. I was so happy thinking how wonderful the voice of a human being was. I was captivated by the feeling of playing in this fairland.

Electrocompanier ECM 1 MKII ¥980,000

•Supported file formats: DSF, DFF, AIFF, ALAC, APE, FLAC, WAV, etc. •Supported sampling frequencies: PCM: ~192kHz · 24 bit, DSD~5.6MHz •Digital input: 2 coaxial lines (RCA), 2 optical lines (TOS), 1 Ethernet line (RJ45), 1 USB line (A type) •Analog Output: 1 balanced line (XLR), 1 unbalanced line (RCA) •Digital: 1 coaxial line (RCA) •Notes: Wi-Fi compatible •Dimensions/Weight: W470 ×H80×D381mm/8.3kg Contact: CS Field Co., Ltd. 076(491)2207

Phasemation's top-of-the-line MC cartridge that uses a diamond cantilever.

phono cartridge

Superb listening experience. Remarkable vast spatial expression

Hiroji Onodera



Since its founding, Phasemation has been focusing on ax cartridges and are always We have a lineup of excellent products. The flagship MC type PP2000 has received high praise in various places, including being selected as one of the magazine's reference cartridges. Creating a product that exceeds the PP2000 must have been a major challenge for Phasemation, but with the completion of the PP5000, it can be said that the company's cartridges have entered a new generation. That's because it's been a great success.

The most important feature of this device is the use of diamond for the cantilever. As you know, the cantilever bar plays the role of transmitting the vibrations of the sound groove picked up by the tip of the needle to the generating coil (for MC type; magnetic white for MM type). Therefore, in theory, the performance required of a cantilever bar is to accurately transmit vibrations without compromising the followability of the needle tip. In that sense, the conditions for an excellent cantilever are hard and unstable, and diamond, which boasts the highest hardness, is the ultimate

It's a choice.

Cantilever materials include general aluminum, Boron is preferred for high-end models.

There are also examples of ruby, beryllium, carbon, and wood, each of which has its own tones and charm, and although it is difficult to compare them with others, it can be said that nothing beats diamond in terms of performance.

However, in order to achieve the excellent performance of diamond, careful consideration is required, and for example, with the P P5000, the accuracy of the attachment angle of the stylus tip to the cantilever has been increased from the conventional 5 degrees to 3 degrees. (The company's commitment is to use natural diamonds instead of artificial diamonds at the tips of the needles.) The sound quality is said to be completely different, a newly designed damper 1, precision polishing of the yoke that forms the magnetic circuit, a new body shape to suppress unnecessary vibrations, and a method of fixing the internal lead wires.

Bright and clear color

You can hear a definite diamond effect in the sound. The response is consistent across the entire area, and Tokuchiku is the best in terms of spatial expression. It also has a nice bouncy suppleness, making it extremely comfortable to listen to. It's a great sound that lets you immerse yourself in music.

Phasemation PP5000 ¥1,350,000

•Generation method: MC type •Output voltage: 0.3mV (5cm/sec, 1kHz) •Internal input
 Peedance: 40 •Pressure: 1.7-2.0g White weight: 14.3g •Contact: Kyodo Electric
 A Engineering Co., Ltd. Phasemation Sales Department 045 (710)0975

Improved damper part based on MC Anna Diamond. Flagship model with new materials

phono cartridge

Attractive, transparent and light sound

Hiroji Onodera



In recent years, phono cartridges that use diamond cantilevers have been appearing one after another, but it can be said that the beginning of this was the "MC Century", a model commemorating the 100th anniversary of the founding of Danish company Ortofon (2018). Attempts to use diamond, which is said to be the hardest material on earth, in cantilever bars had already been made in Japan since the 1970s, but the idea seemed to have stalled.

However, over time, Ortofon Diamond cantilever rated "Fair"

The results installed in the commemorative model are outstanding.

I was truly surprised by the natural sound, which was the ultimate in cartridge quality.

The base of the MC Century

was the "MC Anna," which was an air-core type with a boron cantilever, and was an excellent model with various sound quality measures implemented in the body. It's confusing, but the limited edition commemorative model sold out quickly, and now MC Anna is wearing a diamond cantilever model.

The "MC Anna Diamond," equipped with the

"MC Diamond", which has recently appeared, is the successor to "MC Anna Diamond". As the name suggests, it is an air-core damper featuring a diamond cantilever, but in order to bring out the characteristics of diamond even more, the damper is made with MWCN T (Multi-Wall Carbon Nano Tube) mixed into the rubber. newly designed exclusively for this purpose. This is probably the biggest point of this machine. Ortofon is able to develop rubber and resin independently, which is a major strength in product design. The needle tip shape is Replicant 100, and the coil wire is made of high-purity oxygen-free copper wire. The main body is SLM made from laser-molded titanium powder wood, and soft TPE is combined at the bottom for damping. A clear and straightforward sound is a common characteristic of Ortofon's diamond cantilever-equipped machines, which have continued since the MC Century, but this unit gives the impression of even greater transparency across the entire range, with a wider range and lighter sound. The new appeal lies in the quality of the sound.

Dew.

Ortofon MC Diamond ¥1,180,000

•Generation method: MC type •Output voltage: 0.2mV (5cm/sec, 1kHz)
•Internal impedance: 60 •Pressure: 2.6g White weight: 17.5g Inquiry
Destination: Ortofon Japan Powder 03 (3818)5243

Krell's first phono equalizer amplifier with detailed impedance/gain settings

phono equalizer

A fresh sound full of power. The singing voice has penetrating power

Koji Yamamoto

A high-end ode representing the United States!

Introducing the K300p phono equalizer from Krell, the icon of O. It has a cosmetic design reminiscent of the same company's integrated amplifiers, with a spherical bulge in the center of the front panel, and independent MC/MM input terminals, and DIP switches on the back allow fine adjustment of load impedance and gain. Kawa Riki is equipped with X LR balance and RCA single end systems.

Phasemation PP2000

Installed Technics SL1000R

I connected this unit and listened to the sound while comparing it with the Accuphase C47 (1000 setting). At first, I set the gain to its maximum value, but the sound seemed a little cramped, so I lowered it to 60, which made the music breathe more easily. Also, when I compare the sound pressures of the balanced output and the single-ended output, I get the impression that the latter has a better audible band balance. I decided to listen to the code. The overall impression is that it has a rich mid-low range.

A fresh sound full of power. sound

Not too harsh, like high-quality cotton
It has a pleasant tone.

Ellis Springs (Valtere Reko)

I was deeply impressed when I listened to the records of The reason for this is that female voices are very charming and have a penetrating power. I guess one of the characteristics of this phono amplifier is that it emphasizes the husky sound. The Japanese recording album (ECM) by Austrian jazz guitarist Wolfgang Muthspiel was also amazing. It expresses a glossy clean tone reminiscent of a direct connection to a Moose Beer amplifier, and intimately depicts the incandescent nature of the three interplayers.

What surprised me about Yoshitaka Minami's 1982 album "7th Avenue South" was the appeal of the vocals. It can be said that the charm of this phono amplifier is summed up in the fact that it gives you a strong sense of presence, as if you are singing right in front of your eyes. The medium groove you can hear in Yumin's "Pearl Earrings" also has a honeyed taste. The K300p listening experience made me realize once again the skill of Japanese studio musicians in the early 1980s. was.

Krell K300p ¥1,350,000

•MM MC compatible type •Corresponding impedance: 100~1KΩ (8 stages/MC), 47KΩ (MM) •Dimensions/Weight: W438×H105×D289mm 4.5kg •Notes: Specifications in the photo
The top is black, others are silver •Inquiries: Akka ☎03 (5785) 0661



Ed Meitner's second phono equalizer for optical cartridges

phono equalizer

Positive and sharp cut, enjoy lively sound

Takahito Mura

EMM Labs in Calgary, Canada, has released a phono equalizer for optical cartridges with two models. This DS-EQ2 is a new product from sister brand Meitner Audio, and the already released DS1EQ1 is a release from the EMM Lab brand.

Mr. Ed Meitner, the company's owner, was fascinated by the sound of water inside an analog record produced by an optical cartridge, and his initial idea for a product was to include an MM/MC type phono equalizer circuit. So much so that they omitted it and made it a machine exclusively for optical cartridges.

Meitner's DS-EQ2 is a DS audio. With the release of DIO's 3rd generation DS003, this project was designed to allow even more people to enjoy the sound of optical cartridges. In Japan, the DS-EQ1 The nice tag costs 1.3 million yen excluding tax, but this DS-EQ2 is less than half the price, at 600,000 yen excluding tax.

Although the detailed circuit configuration has not been made public, the DS-EQ2 is a class-A operation balanced amplification circuit DS1EQ1.

Even with the same class A operation, the amplifier circuit is It appears that the company has been able to reduce costs and save space by adopting a dual-band configuration. Although it is different in scale from the DS-EQ1, it is equipped with the same switching power supply unit. In this magazine's listening room, we are listening to a Technics SL1000 R with a DS-W3 optical cartridge installed. It's a product that makes you aware of its positive tonal tendency, with its refreshing and light rhythmic movement, which is very similar to the sound of EMM Lab's DS-EQ1, which I remember listening to in the past. The noise level was kept low enough, and I was able to enjoy the sharp and lively sound from the piano at the beginning of Donald Fagen's "Maxine." I was impressed when I listened to it on DS-FQL, but in Anselmet's "Nisuke Har", the woody sound of the castanets and the timbre of the flute that seemed to pierce in the direction of Oi left an impression.

The sound produced by the DS-TQ2 is attractive. With a humanoid speaker like the B&W801D4, the majestic low range of Britten's "War Requiem" is slightly diminished, but with a small aircraft, you probably won't notice it.

Meitner Audio DS-EQ2 ¥600,000

-Phono equalizer for optical cartridges -Dimensions/weight: W338 x H67 x D286mm. 3.7kg • Contact: Stock Digital Stream ☎042 (747) 0900

Soul Note introduces a converter that creates a zero link with a USB type A output device

ZeroLink dedicated USB bridge

It will be your trump card for improving the sound quality of USB connections.

Takahito Miura



The top-of-the-line 3 series newly released by Soul Note is the R3, which is equipped with TSB (3) input terminals, and zero link output terminals in the same housing as the 10ML clock generator X3. Soul Note uses this unit as a USB-Zerolink bridge to create the ultimate separate USB connection

DAC. Z3 transport of the top 3 series (1,166,000 yen including tax) has exactly the same functions, but I'm sure there are many audio filers who use USB but don't need AN-connected network audio for the time being. The product that reflected these opinions was the B3, which narrowed down its functions to a USB connection only and had a price tag of 28,000 yen including tax.

The built-in USB (B) input will be used to connect not only PCs and Macs, but also audio-only NAS such as DELA and fidata. There are currently two Soul Note devices that can be connected to this unit with Zero Link: the D/A converter 1 D3 and the SACD/CD player S3Ver.2 (including reference). There are also three models of Sforzato, which jointly developed the Zero Link standard.

Pavol DSC-Dorado and D SC-Vela.

Zero Link is a mechanism that sends a high-order clock signal from the D/A converter side to devices such as this unit and Z3, and performs completely clock-synchronized digital transmission.

In this magazine's listening room, we use the S3 reference as a DAC, and connect the built-in USB (B) terminal directly to the USB output of DELA, an audio-only NAS, and connect the zero link connection from the same USB output via B3. When I compared the sound quality when connected, it was clear that the zero link connection with B3 gave me a high-grade sound. For example, Cal's sound image becomes three-dimensional and clearly drawn, the nuances of the tone are rich, and the spaciousness of the sound field can be felt deeply. Furthermore, if you add the clock generator X3 to the S3 reference in this state, the fuzo focus will become even tighter and a detailed sound will develop, which is interesting. S3Ver.2 (SACD player) and D - B3 improves the sound quality of USB connection This will be your trump card.

Soul Note B3 ¥480,000

•Input terminal: USB 1 system (B type) •Output terminal: ZERO LINK 1 system (DVI) •Dimensions and weight Quantity: W430×H111×D376mm 7.8kg •Note: The one in the photo is premium black, others Premium silver available, ZERO LINK exclusive cable included, January 2023 1||55 from orders Manzo • Contact: Stock CSR 042 (703) 5100

Revived with higher cleaning ability

Claudio's fully automatic record cleaner Takahito Miura



record cleaner

claudio
CLN-LP200T
¥1,130,000

•Model: Sonic record cleaner •Recommended external tank capacity: 19 liters
•Dimensions and weight: Main unit W481 x H230 x D217mm, 14.5 KE, outer tank: W395 x H360 x D190mm •Notes: Disc loader 1, 7-inch record adapter, 10-inch record adapter, and other various options available • Contact: Kabu Noai 03 (6902)0941

Claudio's fully automatic record cleaner

The product became very popular for its water-based ultrasonic cleaning and drying, which did not require any special liquids. However, production

was discontinued in 2020 due to the soaring prices of ultrasonic units and the prices of various components. However, in response to numerous calls from all over the world for its revival, Claudio has developed and released a new and improved product, CLNLP200T.

Although the price has increased significantly due to recent circumstances, we are happy to see it re-appeared.

I have been using the original CLN-LP200 since the company's inception, so I immediately borrowed the new product from the importer for about a week. Original machine and new C at home I lined up the LN-LP200T and listened to about 30 used LP records that I had ultrasonically cleaned.

The CLN-LP200T is about the same size as the shorter CLN-LP 200S, which has an external water tank, but the mechanism for turning the analog board has changed from the conventional belt drive to a direct-coupled direct motor system, making it an imported model. There is no need to go back and replace the belt. Also, it was a feature of the previous work.

Fine adjustment of the water level is omitted, but since I'm using the original machine that didn't have it, it wasn't particularly inconvenient, so I don't think that's a problem.

Now, I'm personally interested in ultrasound. This is the effect of cleaning. Although it is not possible to compare under the same conditions, I did a one-on-one comparison at home and felt that the new CLNLP200T was superior.

At Claudio, we reexamined the frequency of ultrasonic waves used for LP records, and as a result, optimized the cavitation effect that generates microbubbles, thereby eliminating stubborn sound that adheres deep in the grooves that are invisible to the naked eye. It is more effective in removing dirt and dust than previous models.

That's what it means. At the same time, the placement of the ultrasound unit is being reviewed.

The operability is exactly the same, and the ultrasonic cleaning/air drying time of up to 5 minutes remains unchanged. Although you can use regular tap water, the importer recommends using commercially purified water that is easily available online (I use industrially purified water). Based on Ryomoto's request, the sensor that detects the amount of water has been improved so that it can also handle purified water.

Listening disc list

Hiroji Onodera

SACD • Debussy & Ravel: Four Thousand String Orchestras/Italian String Orchestra (Stereo Sound SSHRS068-069)

CD • Tricycle Film & The BB's (DMP/Out of print)

LP • Overseas Tommy Flanagan (Metronome, out of print)

• Mussorgsky Pictures at an Exhibition, etc. Royal Philharmonic Orchestra conducted by Rene Leibowitz (RCA, out of print)

Nobuyuki Fu

CD • Downlight Upright/Brian Bromberg (King KICJ729) Face

• to Face/Gary Burton (vib), Makoto Ozone (p) (Universal, out of print)

digital file

• Dreaming Tsubasa-! Dream of NIKE Ayako Sakigawa (comb) (Waone Records)

• Progressive Dio, Dio Di Basso (Exton)

他

Koji Mayuzumi

SACD Dialogue -Miki Imai Sings Yuming Classics-/Miki Imai (stereo sound SSMS027)

• Tchaikovsky & Korngold: Violin Concerto Anne-Sophie Mutter (vn), Vienna Philharmonic

Orchestra conducted by Andre Previn, London Symphony Orchestra (Deutsche Grammophon) Out of print

CD • Selection and composition by Okihiko Kanno, Stereo Sound Reference Record, Philips Sound Vol.11 (Stereo Sound SSPH3001)

• Berlioz: Symphony Fantastique, Saito Kinen Orchestra conducted by Seizo Ozawa (Universal UCCD1432)

他

Takahito Miura

SACD • Britten: War Requiem/London Symphony Orchestra conducted by Benjamin Britten, etc. (stereo sound SSHRS060-063)

LP • The Nightfly Donald Fagen (Warner/Issue)

• Falla: Ballet music "Two horns/Swiss Romande Orchestra and Stings conducted by Ernest Ansermet (London, out of print)

Digital file Beethoven: Piano Sonata Collection Vol.1: Pathétique & Kamitsu/Naoyoshi Kawamura (p) (RCA

Red Seal) • The Bridge/Sting (A&M)

他

Koji Yamamoto

CD • New Masada Quartet John Zorn (Tzadik/Import Disc)

LP • Seventh Avenue South Hitaka Minami (Sony, out of print)

• Reveal Elles Springs (Valtefe/Import Disc)

Digital file • Mozart: Piano Concerto No. 18, No. 19 Mitsuru Uchida (p. conductor) Cleveland Orchestra (Decca), etc.

Tadashi Yamanouchi

SACD • Beethoven: Violin Sonatas No. 5-7/Frank Peter Zimmermann (vn), Martin Helmchen (p) (BIS/import disc)

CD • Taking a Chance on Love/Jane Monheit (Sony SCP632)

• Mirage/Sabine Deviel (S), Les Siècles conducted by François-Xavier Roth (Warner WPCS13738)

Digital file • Weber: Opera "The Fiend Archer", Staatskapelle Dresden conducted by Carlos Kleiber, etc. (Deutsche Grammophon), etc.

Hiroimi Wada

digital file

• Royal Ballet Gala Ernest Anselmet Fingers Covenant Garden Royal Opera House Orchestra (stereo sound SSHRB004)

• Shostakovich: Symphony No. 4 & No. 11 "1905"/Boston Symphony Orchestra conducted by Andris Nelsons (Deutsche Grammophon)

• Waltz for Debbie Bill Evans (Riverside)

• Our Point Of View Blue Note All Stars (Blue Note) and others

Stereo sound listening room reference equipment list

Speaker system • B&W:801 D4JBL: Project K2 \$9900

SACD/CD player • Accuphase: DP1000+DC1000, DP750 • Soul Note: S3 Reference

Digital file transport • Soul Note: Z3

Preamplifier • Accuphase: C3900, C2900 • Soul Note: P3

Power amplifier • Accuphase: A250, P7500, A75

Prime Amph • Accuphase: E800, E5000

AD player • Technics: SL1000R • Luxman: PD171A

Phono cartridge • Phase Mation: PP2000 • Audio Technica: AT-ART9XI, AT-ART9XA, VM760SLC • Denon: DL103SA

Phono equalizer • Accuphase: C47, AD2900

Clock Generator • Soul Note: X3

Headphones • Audio Technica ATH-ADX5000

Audio rack • Andante Largo: ALT12A, ALT600T • Finite Elemente: HD01 • Quadraspire: Q4D Vent • Taoc: CSR2S-

L Line cable • Stereo sound: Reference cable SSRCA1.5, SSXLR1.5 • Accuphase: AL15, ALC15

USB cable • Aim Denshi: AIM UAC-F010 • Furutech: GT2 USB-

Speaker cable • Stereo sound B: Reference cable SS-SPC

clock cable • Soul Note: RCC1

NAS DELA: N1Z/3-S20-J, N1A/3-S20-J, data: HFAS1-XS20/K

Switching hub • DELA: S100-

B-J Disc stabilizer • DS audio: ES001

other

Marten's entry line
"Oscar" series debuts

Takahito Miura

Marten, one of Sweden's leading high-end loudspeaker manufacturers, has introduced the new Oscar series, an entry-level model from the company that approaches the sound quality of higher-end models. Here we would like to introduce the Oscar Trio, a 2-way floor standing machine that has just arrived. All of the important driver units that embody Marten's sound are custom-made and equipped with ceramic diaphragms. The two midrange woofers are 7" diameter, dome-shaped (not inverted domes). The tweeter is 1" diameter, with luxurious internal wiring by Jorma Design.

Marten

Oscar Trio

¥1,400,000 (pair)

•Model: 2-way 3-speaker - bass reflex type •Month unit Woofer 17.8cm cone type x 2, tweeter 2.5cm dome type •Crossover frequency: 2.5kHz

Sensitivity: 89dB/2.83V/m Impedance: 60Ω •Dimensions /Weight: W200×H1,090XD400mm 30kg

Thoughts: The finish in the photo is a piano White, other colors available

•Contact: (Zephany) 03(5917)4500

The crossover circuit is it has a second-order slope characteristic. Uda. Another unique feature of this machine is that it does not have a passive radiator and has a bass reflex port on the bottom. The slanted enclosure is made of 25mm thick fiber laminate material with internal MDF bracing. The total height is approximately 109 cm and the weight is 30 kg.



speaker system

D/A converter "C1"

Enhanced clock accuracy, algorithms, etc.

Takahito Miura

CH Precision, a high-end audio company from Switzerland, has released the C-2 stand-alone D/A converter, which offers significantly improved performance.

The biggest improvement point is the time axis, which is the most important point in digital audio.

This is a thorough pursuit of precision. A newly developed shunt regulated power supply and MEMS-based clock have dramatically increased its accuracy. In addition, by acquiring four times the processing power compared to the previous model, we have improved the CH-PETER algorithm and improved 32/32-bit fixed-point processing.

been realized. The

installed DAC element is

the same, but with AES

E BU and coaxial

digital input, it supports

192k 24-bit PCM

and streaming up to

768 kh/32-bit and

DS D512. The dedicated

CH Link HD digital

connection with the

company's D15 transport

enables the transmission

of DSD native M

QA data in the digital

domain. Upgrade the conventional

C1 to equivalent

to C1/2 for a fee.

What you can upgrade

Also, CH Precision

It can be said that this is an appropriate consideration.



D/A converter

CH Precision C1.2 ¥5,100,000

Flagship AD player commemorating SME's 60 years of audio business

Takahito Miura

British SME launches Model 60, a top-of-the-line analog player. This is a very special product that commemorates the company's 60th anniversary of producing audio products (tone arms). Model 60, which features four massive legs, has been accumulated by SME.

This can be said to be the culmination of all the know-how that has been accumulated over the years. The legs achieve ideal decoupling both vertically and horizontally, giving a high degree of stability to the platter's rotation. The weight of the turntable itself is 40 kg. Another feature is that the speed controller and power supply are in separate housings.



AD player

SME Model 60 ¥12,000,000 (estimated price)

W557x Tone arm section (Series VA) •Model: Dynamic balance type
Turntable section •Drive method: Belt drive •Rotation speed: 33-13.45rpm •Dimensions/weight: Small body/W170xH87xD295mm 2kg, power supply unit/W190xH83xD243mm/4.2kg •Contact: Co. Ligere 03 (6240) 1965

The installed
The arm is SM E series VA. It is an advanced specification of the highly acclaimed top-class Series V, and monocrystalline wire made by Crystal Cable is used for internal wiring. Exterior finishes include brushed black and brushed silver, with surface hardening. Four types are available: black, blue and silver honeycomb with a honeycomb pattern, and a diamond treatment and hand-polished finish.

MC cartridge equipped with a diamond cantilever commemorating the 60th anniversary of our founding. Limited to 60 pieces worldwide

Takahito Miura

Audio Technica celebrates 60 years in business. The year has come. As part of this commemoration, a special MC-type phono cartridge "AT-MC 2022", which is limited to 30 pieces worldwide, will be released on January 25th. AT MC2022 is a cantilever

This is a rare phono cartridge in the world that is made from a single piece of diamond using the CVD process from the bar to the tip of the stylus. The shape of the needle tip is microlinear, and the cantilever part is a square prism with a square diameter of 2 mm. That's see Audio tape with excellent par-tition

It is combined with a generator that has Kunita's unique iron core power generation coil. The magnetic circuit is based on that of the ATART9X, but the thickness of the front yoke has been increased by 0.6 mm to increase the magnetic flux density. Output voltage is 0.55W, standard stylus force is 1.8g. The base part is made of aluminum, and the beautiful housing with black cloisonne decoration is made of titanium. Undercover is wrong. It's made by Stomer. The price of the AT-MC2022, which also comes with a luxurious solid natural wooden case, is 1.32 million yen including tax.



phono cartridge

Audio Technica AT-MC2022 ¥1,200,000

•Generation method: MC type •Output voltage: 0.55mV (5cm/sec, 1kHz) •Internal Input Peedance: 120 •Stylus pressure: 1.8-2.0g (proper stylus pressure: 1.8g) •Wtite amount: 9.5g
Consideration: Limited to 60 units in Yamakai •Contact: Audio-Technica Co., Ltd. Customer Service Desk

0120-773-417



We purchase audio at high prices. We are

increasing our purchase of analog related products and accessories!

Carefully selected used items list (all prices including tax)

Amplifier	
SONY TA-F222ESJ...	¥19,800
ONKYO A-817XX...	¥26,800
Accuphase E-307	¥168,000
DENON PMA-SA11	¥129,800
UESUGI U.BROS-12-	¥148,000
JEFF ROWLAND CAPRI SII (with PHONO)	¥268,000
Accuphase PX-600	¥278,000
SANSUI B-2103 MOS VINTAGE...	¥118,000
LUXMAN MQ-50	¥98,000
Digital players, D/A converters, etc.	
DENON DCD-1650SE	¥69,800
ESOTERIC D-05	¥168,000
marantz ND8006	¥108,000
LINDEMANN USB-DAC 24/192	¥19,800
Speakers/speaker related	
MONITOR AUDIO BRONZE BR-1	¥15,800
MONITOR AUDIO MASS-2G SAT + MASS-Stands	¥19,800
MONITOR AUDIO PL-20011 (exhibit)	¥698,000

TEAC S-300 NEO SP	¥19,800
JBL Control X	¥26,800
JBL S4600	¥358,000
Klipsch PB-61 II	¥39,800
FOSTEX FE208Σ+BK-20	¥39,800
HARBETH Monitor 30.1+HSS-30C	¥278,000
B&W CM1/MR + FS700CM	¥64,800
B&W CM7/MR	¥69,800
Vienna Acoustics T-2	¥84,800
TANNOY Rectangular York/HPD385	¥220,000
MONITOR AUDIO STUDIO + STAND (exhibit)	¥184,800
MONITOR AUDIO STUDIO + STAND	¥154,800
JBL JS400 (set of 4)	¥49,800

BENZ MICRO PP1	¥64,800
PhaseTech T-3	¥24,800
MICRO ST-10	¥5,500
Audio Design HAS-3LB (3F-IM)	¥24,800
TAOC SCB-45	¥19,800
SAP RELAXA 530	¥44,000
STAX SRM-T1W	¥39,800
QUADRASPIRE QAVX-CH-SO (1 shelf board, new)	¥42,900
QUADRASPIRE P-180/19MS	¥4,400
NANOTEC SYSTEMS G.S #305 nano3 Premier /1.8m	¥39,800
CSE RG-100-	¥39,800
CSE Z-30	¥29,800
Andante Largo SM-5AT2/P3...	¥38,500
Andante Largo SM-5AT2/P4	¥29,700
ZONOTONE Blue Spirit-777AC XLR/1.0	¥14,800
NANOTEC SYSTEMS GS#201 NANO3/XLR1.0	¥15,800
Harmonix HS101 Improved XLR/1.0	¥19,800
ACROLINK 6N-D5070 II /1.5	¥19,800
Ortofon 7-Nines Pure Copper	¥4,980
ACOUSTIC REVIVE DSIX-1.0	¥19,800
ZU CABLE JULIAN/2.0..	¥24,800

Analog accessories etc.	
DENON DP-1300MK2	¥118,000
THORENS TD240-2	¥79,800
THORENS TD295/4	¥89,800
TEAC TN-350-SE/CH (new)	¥39,800
TEAC TN-4D-SE/WA (new)	¥69,800
Audio Craft PE-500MM	¥39,800
Accuphase AD-2850	¥179,800



Sumiya Sound Gallery

TEL 054-251-1231

FAX 054-266-5351

<http://www.sumiya-sg.co.jp>

*Winds Falconer 102, 2-6-15 Falconer, Aoi-ku, Shizuoka 420-0939 *Business hours=10:00-19:00 (closed every Wednesday) Parking available for 2 cars



TANNOY Autograph (15" with GOLD)

The most recommended combination
of TANNOY and marantz



marantz #7



marantz #9

Website renewal! www.halltone.com

Great deals on popular products! Must-see

You can download the product catalog!

We have an extensive lineup of vintage amplifiers and speaker systems.
You can see the inside details in PDF. Compatible with smartphones!!



UKLOWTHER UNIT

PM-6A Special price ¥150,000/1Thursday
PM-2A special price ¥220,000/1*
PM-4A special price ¥280,000/1 piece
Edge/Damper Same Leather Permanently Used



universal tweeter

City price ¥75,000/1 piece

Connecting to full range/2-way speakers
Enjoy high-quality sound like never before.
You can 5,000Hz~20,000Hz
Fully torqued with titanium alloy diaphragm
The original mood sound can be faithfully reproduced.



*Available in 4 colors: black/gold/green/beige.

audio & record
Hall Tone City
YOKOHAMA

Whole Tone City Yokohama
TEL.045-323-2966

Nice Urban Nibankan 101, 11-3 Hordai Oomachi, Kanagawa-ku, Yokohama 221-0824 Business hours/PM12:00-PM7:00 Closed on Wednesdays and Thursdays



ideal audiovisual
 The path to space creation

We design the ideal audio room/home theater that is suitable for your favorite system.

For audio rooms and home theaters, in addition to preventing sound leakage (sound insulation/soundproofing), preventing noise from air conditioning/heating/ventilation equipment (silencing), and controlling sound through interior finishes (sound absorption/reflection/diffusion), consideration should be given to AV equipment such as speakers and screens. A design that integrates interior design, lighting, and interior design is desired.

We offer everything from concert halls to audio rooms, home theaters, music practice rooms, and studios. For buildings such as Geo, where audio and video are the lifeblood, we provide comprehensive design including architectural design, acoustic design, and AV equipment design.

Based on our extensive experience and solid technology, we pursue the creation of comfortable, high-quality original spaces by incorporating the best sound and image images into books and book lines.

◆New home construction, extension/renovation, interior renovation

◆We also accept designs for local areas.

During the design stage, Futagawa will supervise and provide guidance during on-site surveys and meetings. (In addition to Kanto, we have experience in Hokkaido, Tohoku, Chubu, Kanmon, Shikoku, and Okinawa.)

◆Although we will not perform any construction work, we will be responsible for supervising the construction process. We can also introduce you to reliable construction companies if you wish.

◆Design works are introduced on the following homepage. (Includes content published in Stereo Sound magazine)

SINCE 1991 Class Architect Office Architectural Design + Acoustic Design

AAD A&A Design

Person in charge: Takeshi Yamamoto

3-40-1-604 Maehara-cho, Koganei-shi, Tokyo
 184-0013 TEL: 090-6112-9476 www.aad-ar.com E-mail: info@aad-ar.com





Our company's selling point is genuine technology, but our prices are also a bargain. Safety + Reliability + Technology! No sound is emitted from the catalog. Check it out for yourself!

Please contact us for Tanzawa special price.

We have world famous machines!

McIntosh
MA8900



LUXMAN
L-507Z



Accuphase
E-800



ESOTERIC
N-05XD



Rakuten Shopping, Amazon, and our online shop (search for "Tanzawa Denki") are also popular. Please feel free to inquire about special prices by email or phone.

TANNOY
Turnberry/GR



JBL **L100**
Classic



B&W
Bowers & Wilkins

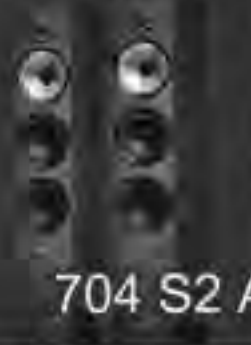

FOCAL



JBL **4349**



704 S2 ARIA 926

Please feel free to contact us regarding audio products that you are no longer using. High-value purchases and trade-ins of used items are welcome.

If you would like to try it out at our company, you can also try it out on your favorite CD. (*Analog records are also available)

visual audio center



Full-fledged audio center



We deliver nationwide. Items over 20,000 yen are basically free shipping. *Excluding some areas

For high-end audio & home theater

TANZAWA

Tanzawa Denki Co., Ltd., a leading domestic and international manufacturer agent

Tanzawa Electric Co., Ltd. provides a 5-year warranty (separate option) excluding some products. Please ask a staff member for details.

8055-233-0033 (Main)
Business hours/AM10:00-PM7:30

www.tanzawa.co.jp



Stereo Sound
STORE

Book information

Now On Sale!

Etsusai
Rakusei

Kouki Yanagisawa

high end audio review

The author who continues to be the leading authority

More than half a century~1964~2019~

Written about my audio life

Memoirs

Kouki Yanagisawa's first book



“再生悦楽 ~My Audio Reminiscences~”

Written by Kouki Yanagisawa

“ My passion for audio shows no signs of cooling down yet.” Audio critic Yanagisawa, born in 1938. Kouki has been involved in audio for over 50 years, from the time he started audio as a hobby at the age of 26 to the present day.

An audio essay that talks about the history of audio.

The popularity of stereo sound, which includes information on current events in the audio world.

Serialized. A book with additional newly written essays.



Introduction

- Fu-Paku's audio prehistory
- Finally got my own audio system
- Become the author of "Stereo Sound" magazine
- It's hard to give up my interest in devices that are currently on hiatus.
- I gave up on becoming a designer.
- Is the Margamp system heaven or hell?

- I moved again, and the CD era was approaching just in time.
- Compact disc introduced
- Between CD, SACD and analog

•Re-cow pleasure

List price: 2,750 yen (tax included)

46 size 428 pages

ISBN:978-4-88073-444-6

Stereo Sound Co., Ltd. Sales Department • Please use our homepage to make your request.

158-0098

5-12-11 Kamiyoga, Setagaya-ku, Tokyo

Mail order only dial: 03-5716-3239 Please transfer the product price + shipping fee.

Application using postal transfer paper with wood book binding

is also possible. Please enter the product name and quantity in the communication field.



@ss_sales



stereosound publishing

https://www.stereosound-store.jp



Separate volume stereo sound

direct heating triode book

The direct-heated triode is a vacuum tube that was developed in the early 20th century and can be said to be the origin of amplifiers. Its sound has an unparalleled charm full of human speed and transparency, and even today it is used in many types of tubes. Since many brands have been produced, Wataetsu triodes continue to be the main output tubes for vacuum tube enthusiasts. In addition to the well-known 845/211 and 2A3, there are also a number of triode tubes that offer a deep and penetrating sound. Power never runs out. Kion delves into the profound charm of the direct-heated triode as a separate edition of the "Tube Kingdom" following the previously published 300B book and EL34/KT88 book.

At the beginning of the book, we will post a "Kano Guno Fic" that conveys the charm of the latest amplifiers to the fullest. The main text is a compilation of new manuscripts and articles on the "Tube Kingdom" spanning 26 years since its first publication, making this a must-have book for vacuum tube fans that unravels the charm of direct-heated triodes. In addition to listening and comparing them, we will thoroughly introduce their history, structure, and the appeal of direct-heated triode amps.

■Main article content...

- The wonderful world of direct heating triodes
 - "The latest amplifier with color graphics" (new article) Comparison of main direct heating tubes such as 211/845 and 2A3 and research article on vacuum tubes (reprinted article)
 - My encounter with a directly heated triode (new article)
 - The source of attraction as told by skilled designers and researchers (new article)

(Below is the third record article)

- The world of direct heating triode amplifiers
 - "The fresh and rich world of large direct-heated tube power amplifiers: 21/845 amplifier listening notes
 - "The vivid and profound world of incandescent tube power amplifiers | Listening notes for direct heated tube songs such as 21, 2A3, 45, VT25, 30CD, PX25, etc.
 - History and listening comparison of direct-heated triodes
 - "A collection of historical and winter output tubes. List of ratings of all-time famous output tubes | "A list in the world! A sound quality comparison test of all-time and famous incandescent three poles."
 - "WERCA GE/STC/E_EFUNKE...Listening comparison of large thermal triodes"
 - 12A3 Major research on the sound quality of current and vintage tubes, the history and structure of 1211 815 and 212, originating from aircraft transmitters from XX years ago.
- Basics of direct heating triode amplifier craft and vacuum tubes
 - "Enjoy the tube amplifier kit (assemble) = Detailed explanation of the production procedure" "Introductory vacuum tube expander interchangeable tube amplifier basic guide | "My Handicraft - Making the 2A3 Power Pump 50 Power Pump"



Separate volume stereo sound direct heating triode book

List price: 3,300 yen (tax included)

Release: May 31st

SBN:978-4-88073-479-8

Magazine code:67970-17

Recommended products

	EL34/KT88 book List price: 3,300 yen (3,000 yen including book) Release date: May 31, 2021 Magazine code:67970-09 ISBN:978-4-88073-464-4
	300B book List price: 3,300 yen (3,000 yen) Release date: May 28, 2020 Magazine code:67969-94 ISBN:978-4-88073-446-0

Stereo Sound Co., Ltd. Sales Department
5-12-11 Kamiyoga, Setagaya-ku, Tokyo 158-0098
Mail order only dial: 03-5716-3239
<https://www.stereosound-store.jp>

•Please use our website to purchase.

search



www.facebook.com/stereosoundpublishing



The sound and history of the masterpiece "300B" of vacuum tubes

A collection of articles published in "Tube Kingdom"

List price: 3,300 yen (tax included) B5 size, 352 pages Magazine code: 67969-94

Stereo sound separate volume

300B book

The 300B is a legendary product developed by Western Electric in the 1930s. Many are still in production today, and the 300B amplifier is one of the most popular among tube amplifiers. This is a must-have book for audiophiles that unravels the history, structure, and sonic appeal of the direct-heated triode 300B, which is synonymous with vacuum tubes, by compiling articles published since the first issue of "Tube Kingdom". "Tube Kingdom" In addition to recording explanatory articles and sample listening articles published in , we also publish new projects to explore the appeal of the 300B and 300B amplifiers.

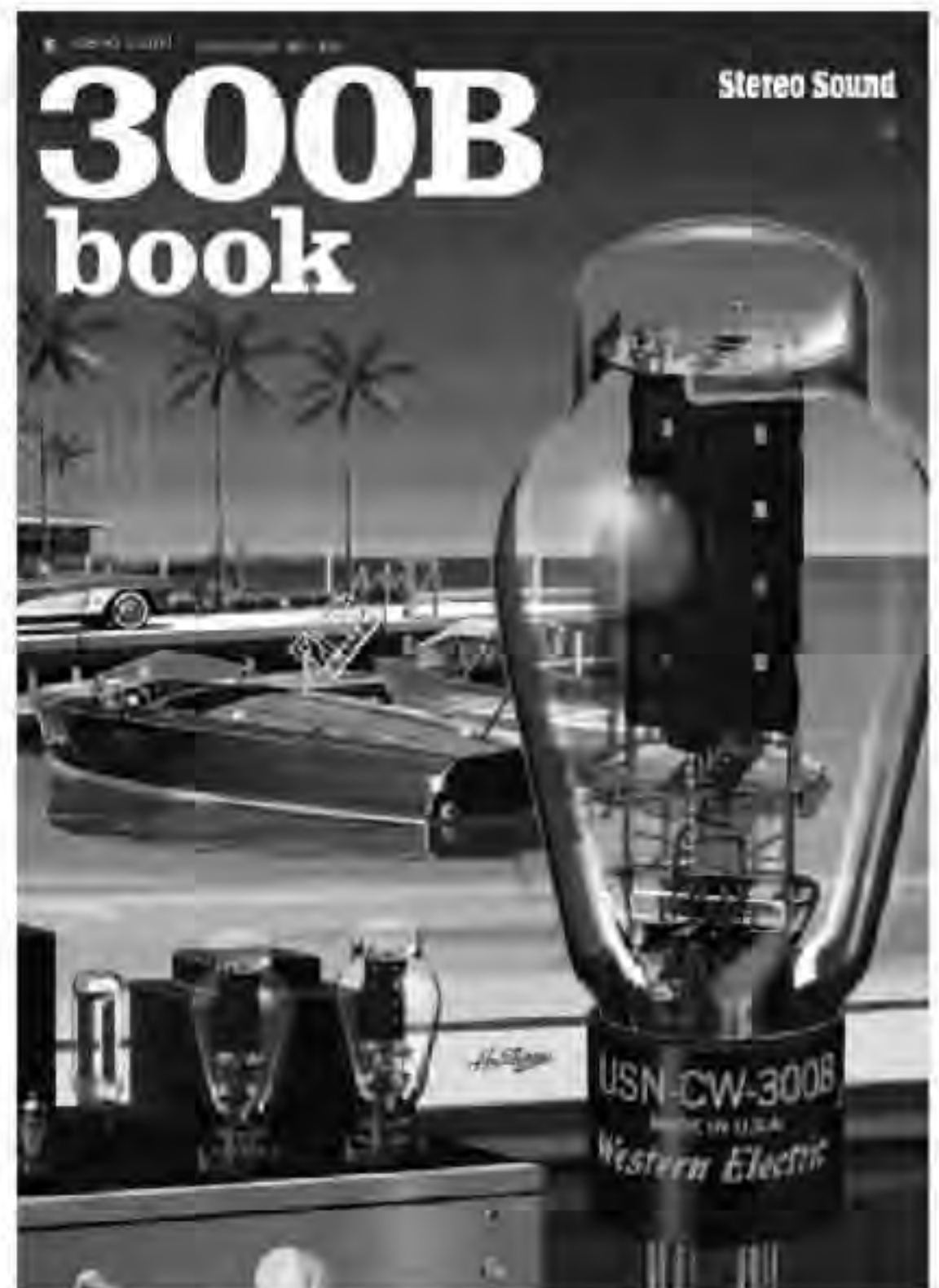

Main contents

■New article

Color Graphic/Modern 300B Amplifier Me and the 300B

Tadaatsu Shin/Shigeharu Kore-eda/Akira Okada The truth about 300B development unraveled from WE literature Akira Okada
 Okada Legendary machine WE86 ——— and 91 — Yuzo Doi

■Reprint article

● Listen to modern 300B amplifiers

"23 models of the latest 300B amplifiers, the pinnacle of vacuum tubes, sampled by theme"

●History and structure of 300B

"300A/B story" "300A/B story part 2" "300B story continued"

●300B vacuum tube listening and topics

"World's first!! Sound quality comparison test of famous direct-heated triode tubes" "WE300B reprint tube is finally here!" "Does remanufactured 300B outperform old 300B?" "Visiting domestic 300B vacuum tube factory"

"Jikken Kobo = Direct heating triode 300B = WE From the era to the current tube Listen to and compare 22 types."

"Jikken Kobo = 14 current types of 300B vacuum tubes + 2 types of WE single blind preview of operation"

●Explanation of famous amplifiers and circuit know-how

"Wiring technique hidden in WE91" "The joy of building kits + easy way to read circuit diagrams"

●Amplifier production article by the writing team

"My Handicraft WE300B Single Amplifier Production" "My Handicraft WE300B Push-Pull Amplifier Production"

Stereo Sound Co., Ltd. Sales Department •To purchase, please visit a bookstore or visit our website.
 5-12-11 Kamiyoga, Setagaya-ku, Tokyo 158-0098
 Mail order only dial: 03-5716-3239
<https://www.stereosound-store.jp>

stereo sawand store



Analyzing and verifying the sound that Eiichi Otaki aimed for in "NIAGARA TRIANGLE Vol.2"

Separate volume stereo sound

NIAGARA TRIANGLE

Vol.2 Reader 40th Anniversary

to life with the latest remastering
Eiichi Otaki's sound comes back



Regular price: 2,750 yen (2,500 yen)
Release date: March 31, 2022
Magazine code: 67970-14
ISBN code: 978-4-88073-475-0
Format: B5 Number of pages: 164 pages



Stereo Sound Co., Ltd. Sales Department
5-12-11 Kamiyoga, Setagaya-ku, Tokyo 158-0098
Mail order only dial: 03-5716-3239
<https://www.stereosound-store.jp>

■Main article content.....
"NIAGARA TRIANGLE Vol.2", which Eiichi Otaki produced in 1982 with Motoharu Sano and Mari Sugi, will be released as a 40th anniversary edition. This book examines all the related sound sources of this work, including past LP records, CDs, and the latest remastering. We also feature the latest interviews with artists who were involved in the album's production, including Ginji Ito, Motoharu Sano, Mari Sugi, Hiroyuki Namba, and Tatsuo Hayashi. "NIAGARA TRIANGLE Vol. 2" will explore the appeal of the song from multiple angles, both musically and sonically, from the background behind its birth. Supervised by music critic Manabu Yuasa.

■CONTENTS

- IN AGARA TRANGLE Vo.2.
Manabu Yuasa's journey through birth
CIN AGARA IR ANGLE VO.2
Full explanation Manabu Yuasa
- Related artists 2022 Interview
Mari Sano Motosugi, Ginji Ito Akiko Kanazawa/Kou Namba
Tatsuo Nobayashi Hideki Matsutake
[Writer: Manabu Yuasa Takayuki Ito] Composition: Takayoshi Ito
- INAGARA TRANGLE Vo.2 40th anniversary edition master
About Rings and Sound Sound Mixes
Dialogue Tetsuya Naito Kei Kakizaki
- Based on the ghost analysis of "Love on Side A"
Verification of past stars rings
CINAGARA TRANGLE Vo.2
Complete verification of major and past formats Manabu Yuasa
Inan: Takamon Ito Interviewer: Editing Department
- IN AGARA TRANGLE Vo..2.
5.1ch surround mix and
360 Reality Audio Shukenki Hio Ohara
- IN AGARA TRIANGLE Vol.2 VOX.
Related sound source/bonus/track verification Kenichi Yasuda
- Gravure INIAGARA RIANGLE Vol.2 VOX "Related
件
- Tracing Shigeru Suzuki's artist
career through vintage audio
Shigeru Suzuki (guitarist x Manabu Yuasa Composition: Takashi Ito
- Interview special edition
Chris Matsukawa speaks
"Eiichi Otaki and Physical Media"
Listening to two compositions: Takatake Ito
- INIAGRA TRANGLE Vol.2]
Album 3C selection for
depth 80's Niagara Sund
Knowing the warm and the heavenly
stream, Ryugo Ito, Kōbai Keiro
Edited by Matsuyama Shinchi 宇佐美 淳
- Otaki Eion head version edited by Manabu Yuasa
- INIAGRA TRANGLE Vol.2" Essay
Shinichiro Kobayashi
-]NIAGARA TRIANGLE Vol.2:
Juyasu Musician & Staff Directory
Ryugo Ito
- Kasai Tetsu Interview
The sound of Eiichi Otaki/1982-1997's work has suddenly begun to sound.
Keyzone Editorial Department
- Takashi Matsumoto's book Takao Ito
- LA LONG VACATION]
Single layer SACD appeared Shinichiro Hachibayashi
- [A LONG VACATION]
A story about the production process of single-layer SACD
by Tetsuya Naito, Keiichi Hayashi, and Takayoshi Ito.

●Please use our website to purchase.

Stainless Steel Wand Stost

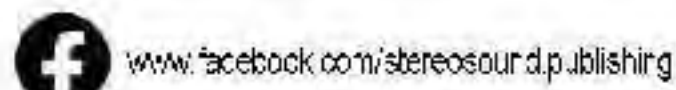



Manufacturers who built the foundation for a society where people can easily enjoy movies and music

[Western Electric]

Movies from around 1900 to 1920 were shown with only images without dialogue or music (called silent movies). However, times changed completely with the release of the movie Don Juan in 1926 and The Jazz Singer released the following year in 1927. This is because the era of talkie movies (synchronized screening of video and audio), which is now commonplace, began. Western Electric (WE) developed this technology, and the sound systems in theaters are also models developed and manufactured by WE (for example, the "555" receiver introduced in Parts 1 and 2 of this magazine, and the "15-A" horn system, "8"- "9"- "10" amplifiers and "41"- "42"- "43" amplifiers) were used.

On the other hand, in the world of music recording, in 1925, an electric recording method using microphones, amplifiers, and recorders was developed (prior to this, acoustic recording methods using large bugles were used). This is another groundbreaking technology developed by WE. This technology has dramatically improved the sound quality of record recordings, making it possible to provide high-quality records to music fans around the world.

In this way, he is a pioneer who has built the world of movies and music/audio as we know it today, and is a unique artist who has always reigned at the highest peak. That is Western Electric (WE).

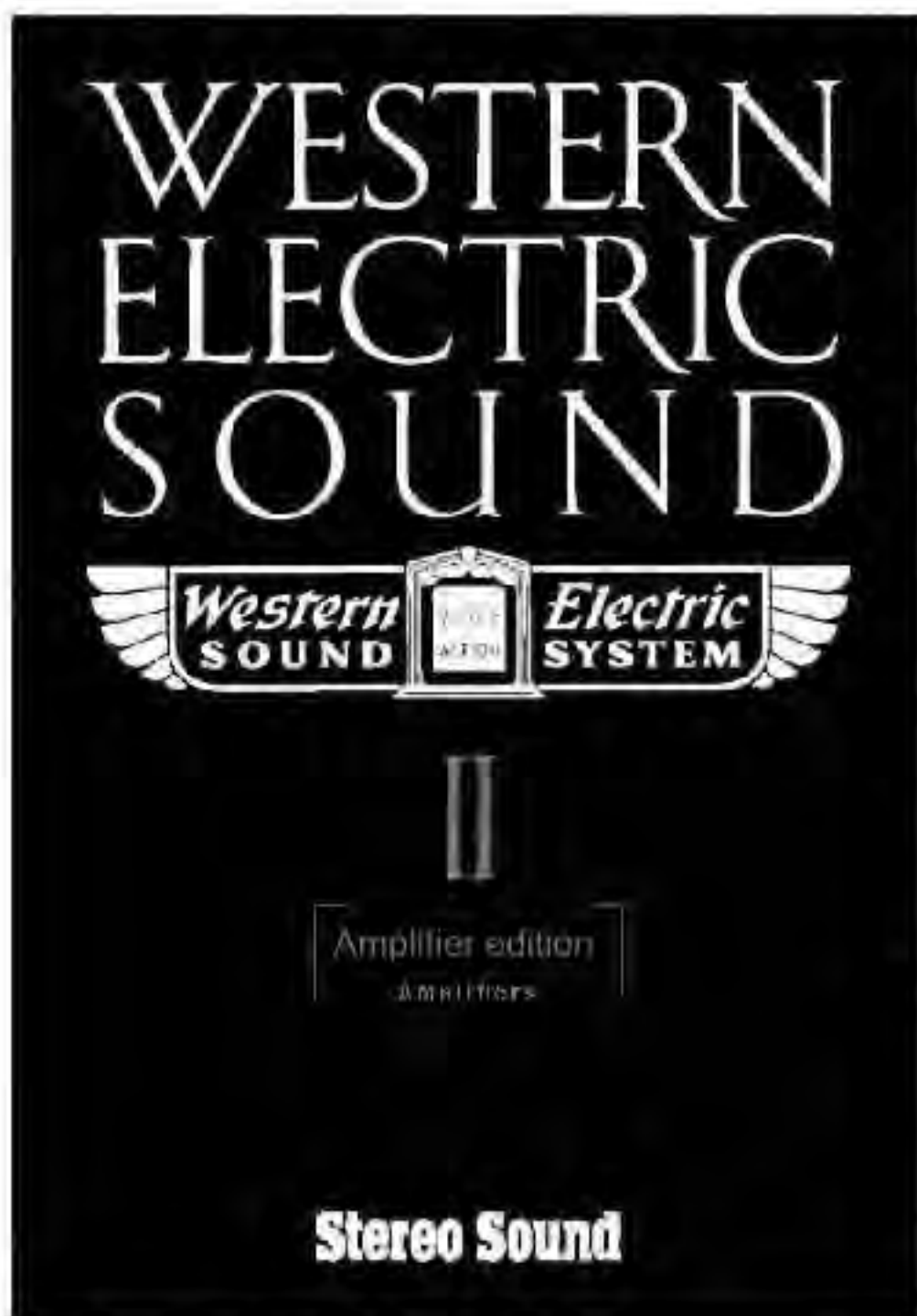

Western Electric Sound

Part-2 [Amplifier Edition]

Price: 8,800 yen (tax included)

Release date: June 17, 2022

B5 size/274 pages Main photo/4 color printing (illustrations etc./1 color printing) ISBN:978-4-88073-477-4



Main article content

- Western Electric Instrument Selection——Shintadaatsu Amplifier
8-A, 8-B, 8-C, 9, 10, 41, 42, 43, 46, 49, 7-A, 14-A, 25-B, 34-A/B, 59-A, D- 95036, 86, 1086-A, 87, TA-7387, 91, 500-A/B, 92-B, 118-A, 105-A/B, 106-A/B, 120-A/B, 121-A/B, 124-A, 141-A, 142-A/B, Westrex A-11+R-11
- Equipment Bulletin
——Electrical Research Products Inc. (ERPI)
[Western Electric original material collection released by ERPI]
8-B, 9-A Type, 10-A Type, 11-A, 41 Type, 42 Type, 43 Type, 46 Type, 55-A, 57-A, 59 Type, 60-A, 61-A, 62-A, 86 Type, 1086-B, 87 Type, 91 Type, 92-B, 95-A, TA-7388, TA-7467-A, TA-7477



Western Electric Sound

Part-1 [Speaker book]

List price: 8,800 yen (tax included)

Release date: December 17, 2021

B5 size/258 pages/

Main photo/4-color printing (illustrations, etc./1-color printing)

ISBN:978-4-88073-473-6



Main article content

- Movie sound Hidetaka Sasaki
●The secret of Western electric lick sound
Conversations with the author
- Western Electric Instrument Standard: Speaker Edition——Tada 雄
●Receiver 555/594-A/D-98634 596-A/597-A / 13-C/Altec 287/Altoe 755 Westrox 1-530-AWH London 2030-A 540-AW/562-AW TA-1151-4 / TA4181-A-728-8/750-A-754-A/B755-A and others
●Horn 7-A/15-A 12-A3-A16-4/22-A TA-7322/25-A/ KS-6368/ KS-6373 26-A 24-A16
●By Te Monitor System Dividing Network/Current Supply Rectifier

Stereo Sound Co., Ltd. Sales Department
5-12-11 Kamiyoga, Setagaya-ku, Tokyo 158-0098
Mail order only dial: 03-5716-3239
<https://www.stereosound-store.jp>

●Please use our website to purchase.

Stainless Steel Wand Stost

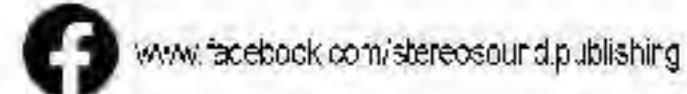

Stereo Sound Back number

•To purchase, please visit a bookstore or visit our website. In addition, it is also possible to include your order using the postal transfer form that is included in this magazine. Please write the magazine name and number in the correspondence column. Please transfer the shipping fee listed above.
*Shipping charges vary depending on the destination. For more information, please see "Shipping/Shipping" on our website.



No.224 2022 AUTUMN List price 2,640 yen (tax included)

●sample the appeal of 40 latest speaker models
●[Audio Hall of Fame] Visit to model users and



No.223 2022 SUMMER Regular price 2,750 yen (tax included)

Hall of Fame I want to pass it on to the future
105 Audio Components ●Audio



No.222 2022 SPRING Regular price 2,420 yen (tax included)

development: Modern cutting-edge speaker B&W 80104 major research
Thorough discussion Explaining to the person in charge of sound in test



No.221 2022 WINTER fixed price 2,640 yen (tax included)

●Stereo Sound Grand Prix 2021
●Best Buy Component 563



No.220 2021 AUTUMN Regular price 2,120 yen (tax included)

●Volume essay That's why I can't stop using audio
●The latest monster power amplifier



No.219 2021 SUMMER Regular price 2,420 yen (tax included)

- This speaker, hot!
- Union trial 7 models of Tentoha speakers



No.218 2021 SPRING Regular price 2,420 yen (tax included)

●How to listen to a critic's
●The appeal of Niyamashiro entry class speakers



No.216 2020 AUTUMN fixed price 2,420 yen (tax included)

cutting-edge speaker models bring you the best of Shimasaki
●Thorough comparison of "3 rival models" by type ●5

Stereo Sound back issue stores

●Hokkaido/Tohoku	
Junkudo Bookstore Asahikawa 旭川	Asahikawa
MARUZREN & Junkudo Bookstore "Black Store" Bunkyo-ku	Shinjuku ward
Bookstore Hakodate Reiwa Store	Hakodate East
●Kanto	
ACADEMIA IAS Tsukuba store	Tsukuba City
Book Depol Music	Saitama City
東京旭屋書店 新越谷店	Kaitoryu City
Kinokuniya Bookstore Niotakanomori Store	Ina City
Sansendo Bookstore Sogo Chiba Store	Chiba mouth
Kumazawa Bookstore Premier Hamoto Store	Chiba
Junkudo Bookstore Minamifunabashi store	Funabashi City
Takyo Asahiya Bookstore Funabashi store	船橋市
Maruzen Marunouchi Main Store 3F	Chiyoko Ward
Shosen Book Tasaw 4F (TEL03-5296-0051) Chiyo Ward	Chiyo Ward
Hakurindo Yodobashi AKIBA store	Chiyoda Ward
Yaesu Book Center Main Store 3F	Chuo-ku
MARUZREN & Junkudo Bookstore Shibuya Store Shibuya Ward	Meguro
Tokundo Bookstore Gakugei University Store	Sedaya Ward
Kinokuniya Bookstore Tamegawa Takahimeya Store	Shinjuku ward
Kinokuniya Bookstore Shinjuku Main Store	Shinjuku ward
Book First Shinjuku Store A Zone	Shinjuku ward
Music 音楽 Sagaya Store	Suginami
Junkudo Bookstore Ikebukuro Main Store 9F	Tochicho ward
Sansendo Bookstore Ikebukuro store	Tochicho ward

G-Nkudo Bookstore Kichijoji Store	Musashino
Orion Shobo Norte! 大塚	Yachikawa City
Yukihara Tsutsujigaoka store	Chofu City
Keibundo Bookstore Fuchu store	Fuchu ward
Cochannoo Wakabadai store	Inagi city
ACADEMIA Kumazawa Bookstore Sakuragaoka store	Tama City
Maruzen Tama Center store	Tama City
Gibundo Bookstore Tazen Center Store	Tama City
Maruzen Lazona Kawasaki store	IJSaki City
KaBoS Miyamaedaira store	Kawasaki City
ACADEMIA Kohoku store	Yokohama
Junkudo Bookstore Fujisawa Branch	Fujisawa City
●Chubu	
Bunendo Shoten Wisteria Tree	Miyama City
Utsunomiya Kanazawa Korinbo store	Kanazawa City
Book Miyama Kanazawa Minami store	Azawa ward
Super KaBoS Shingu store	Fukui Toba
Junkudo Bookstore Okajima Kofu store	Nagai City
Maruzen Matsuyama store	Matsuyama
Heiando Ina store	Ina City
Maruzen & Junkudo Bookstore New Shizuoka Store	Shizuoka City
Hoshino Shoten Kinetsu Passo Store	Nagoya city
Miraiya Shoten Nagoya Chayamachi Roku	Nagoya city
Kos T Nok Center	Ena City
TSUTAYA Ogaki store	Ogaki City

●Kinki, Chugoku, Shikoku	
TSUTAYA Yakuchi Marbela	in Yamaguchi city
Risho Shoten Shusei Branch	Tsu City
People's Bookstore Aeon Mall KYOTO Store	Kyoto
Kinokuniya Bookstore Takatsuki store	Takagi Takagi
TSUTAYA BOOKSTORE LaLaport EXPOCITY	Osaka City
Kinokuniya Bookstore Umeda store	City Osaka
Zen & Junkudo Bookstore Umeda store	City Osaka
Junkudo Bookstore Osaka Main Store 3F	City Osaka
Junkudo Bookstore Namba Store	City Shinjuku
Junkudo Bookstore Kintetsu Abeno Harukas Store	Izumo
Junkudo Bookstore Ishiten	Fukuyama
Ima Shoten Izumo store	Izumi City
Keibunsha main store	Hiroshima
Kiuya Bookstore Kurashiki store	City Hiroshima
Junkudo Bookstore Yamadori Ekimae Store	City
Junkudo Bookstore Matsuyama Store	City
●Kyushu/Okinawa	
Maruzen Hakata store	Fukuoka City
Booksmith Opsia Store Junkdo	Kagoshima City
Bookstore Naha Store	Naha city

Now accepting regular subscriptions

4 books per year 12,260 yen (tax and shipping included)

2 years 8 books 21,560 yen (tax included shipping service)

Regular subscriptions including Oyan can be found on the Nisha homepage or by mail with Kiwa binding.

Please enter your name, starting number, and subscription period in the communication column of the flight transfer form.

Please transfer from your local post office. In addition, bookstores may be sold in some regions.

Please note that arrival may be delayed.

@SS_Sales

Stereo sound publications, CD software

I am tweeting information as soon as possible.

Stereosound Co., Ltd. Sales Department 5-12-11 Kamiyoga, Setagaya-ku, Tokyo 158-0098 Mail order only TEL 03-5716-3239 <https://www.stereosound-store.jp/>

STEREO SOUND

NEW MUSIC GUIDE

Classic

Sekihito Tojo,

Hiroshi Miyashita,

Popular

Shinichiro Kobayashi,

Hiroshi Wada

ESSAY *for Audiophiles*

Deep listening to masterpieces

Kentaro Takahashi

Famous songs are ingrained

Shinichiro Kobayashi

reason

There's a reason for famous songs

Atsuya Funaki

musical abduction

Huh Mitsujun

Music guide & essay for audio files

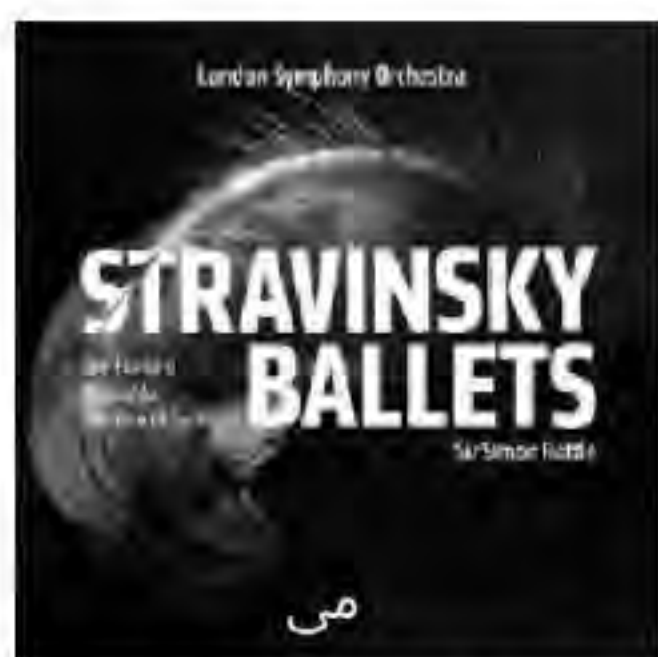

Recorded: September 21 and 24, 2017, Barbican Hall, London

The Firebird (1909-10), Petrushka (1947 revised edition), The Rite of Spring (1947 revised edition)

performance is in good shape, making me wonder if it's a good combination.

The recording is wonderfully clear and has a rich sense of weight, and the

Symphony Orchestra playing so well this season? canceling their contract. Why are Rattle and the London disappointed. They are such a good duo that they are performance. I thought, "Strav", but I am once again London Symphony Orchestra". Such a smooth two-disc set of "The Three Great Ballets of the pieces in one night." In September, Rattle released a but as a long complete version. We performed three [Rattle] said, "We performed Petrushka not as a suite version, most vivid, rhythmic and beautiful. Among these, he a rich sense of weight. It's amazing how "Yuka" is the drum is a wonderfully clear performance with of the striking sounds of the timpani and large this is a bit of an understatement, and that the recording sense of power. However, I would like to add that course, if this hadn't been recorded at the Barbican Hall, the sound would be even clearer and have a tremendous I think it would have been. Of

Stravinsky: Three major ballet music Sir

Simon Rattle conductor London Symphony Orchestra (King KKC6509) SACD Multi-ch. SACD 2ch CD

A song that combines beauty and grandeur Listen to the powerfully punchy conducting.

on the theme of the movie "East of Eden," because the beginning of the Hans song is based Bruckner's music, even though it may be funny. This "First Symphony" is similar to which could almost be called plagiarism. symphonies, he applied many of Mahler's techniques, by Lott's "Fourth", and in his first three three symphonies, Ra was heavily influenced mesmerizing beauty and grandeur. In his first It is a work that is like a bridge in the history of music, but it is one of the best, with There is. This time, for the first time in a while, a good disc came out second movement of the old edition of "Humans", Preparation is modeled after the technique of "Flower Chapter" (the also includes the second movement of the old edition of "Humans") of "Flowers Chapter" (conducted by the giant Fruscha, which This is a somewhat ironic song choice. The technique

Hans Rott: Symphony No. 1

Panberg Symphony Orchestra conducted by Jakub Hrůša (Universal UCCG45063) MQA-UHQCD



Recording: September 30, 2021 - October 2, 2021 (Lotto), December 22, 2021 (Mahler), March 14, 2022 (Bruckner), Bamberg Concert Hall, Josef Keilbert Saal, Germany

Mahler: 2nd movement from Symphony No. 1 "Giant" "Three Flowers", Bruckner: Symphonic Prelude in C minor

Clear and speedy Beethoven.

You can listen to straight interpretations with peace of mind.

Beethoven is a profound, majestic and noble figure, music as long as it is not a majestic performance. orchestra. However, those who prefer period not be suitable for the clarity and speed of an they can listen to with peace of mind. It may who want to enjoy a tight performance that Manacorda edition is a good choice for listeners they can listen to with peace of mind, this who want to enjoy a tight performance that I feel like it's not true. For listeners 2nd movement is an extremely pleasant and propulsive performance, and in the 7th movement, the characteristic 2nd movement in the way the rhythm is carved and the film played in the 4th movement. Progress that doesn't break down isn't bad. The orchestra was founded in Germany in 2001 as its chief conductor from the fall, 2010 This founded in Potsdam by Manacorda, who will serve was born in Turin in 1970. An organization

Beethoven: Symphonies No. 1, No. 2, No.

7 Antonello Manacorda conductor Kammerakademie Potsdam (Sony Music Labels SICC30701-2) Blu-spec CD2



Recorded: October 31, 2020, November 1-2 (No. 7), December 6-7/11 (No. 2), Berlin, Teldec. Kuss Studio, Berlin, December 2-3, 2021, Pierre Boulez Saal (No. 1)



Giorgi Gigashvili (p), Yannick Nézet-Séguin (conductor, p), Philadelphia Orchestra

Recording: January 2022 Philadelphia, 2022 4F Berlin (Frank)

Franck: Violin Sonata in A Major, Szymanowski: Violin Concerto No. 1, Chausson: Poetry Op. 25, Debussy: Beautiful Twilight (Arrangement: Heifetz)

Secret Love Letter

Lisa Batiashvili (vn)

(Universal UCCG45057) MQA-UHQCD

concerto, forming a unified and splendid flow. A piece that combines chamber music and a as well as recent Gramophone label discs, trendy style is to include such iconic titles, as difficult to understand at first glance. The However, there are many that are marked which may be a problem. This time, I chose Georgia (formerly Georgia), piano, played by Orchestra Yuvirii, and 2 collaborations with (Szymanowski, Cherson) (Franck, Debussy) 2 collaborations with piano concerto. In the liner notes: this album features the Szymanov's According to one of her comments, Ru. the overall sound image is unified, combination of chamber music and concerto, It forms a flow. Despite the Recorded in London and Philadelphia.



Recorded: March 2021, France, Lille Opera, La Seine Musical

Debussy: Opera "Pelleas et Mélisande"

François-Xavier Roth conductor Les Siècles, Lille Opera Chorus

(King KKC6457-9)

performed with instruments from the era of its premiere. Recreated with dynamic intensity An opera His commanding characteristics are astute and clear, who wrote this masterpiece of Impressionist music. opera was premiered by the 20th-century genius Lotto, of the Scientist period, making it the most interesting work of "Pelleas et Mélisande." Furthermore, this using a collection of instruments from the beginning recording. The sound of the orchestra was created is soft, but the performance itself is a preliminary As expected, it has clear shading, and the singing "Mélisande" is once again full of realistic expressions. like story that is depicted in many live performances. a story with a typical character, but rather a dream- with dynamic intensity, and sometimes it is not As a drama in which humans intersect, it is recreated It allows you to discover this opera in a new way. rebuild. Perhaps the greatest feature of this is that can be said that this performance is an attempt to Debussy is also interesting. It



Recorded: May 2018 (No. 5), June 2019 (3rd Spring), June 2022 (Pohimira's Daughter) Gothenburg Concert Hall, Sweden

Sibelius: Symphonies No. 3, No. 5, "Pohjola's Daughter"

Gothenburg Symphony Orchestra conducted by Santoumatias Rouvari

(Naxos NYCX10349)

highlight the giants of Northern Europe Vigorous, bold, and large-scale expressions that In the previous issue, young Finnish Makela conducted symphonies by a young Swedish composer. the wonderful complete works of Sibelius's process of recording, has just covered Gothenburg Symphonic Orchestra and is in the 1985), who is conducting the newly released works are quite good, and Lowvalli (born decided to choose these discs. Already, the complete and "No. 2" were very elaborate performances, so I pleasant, sturdy, and large in scale. "No. 1" giant" is expressed as "a northern approach" that is strongly. The image of "Sibelius, the European perhaps brings out the tension even more "Hyora's Daughter" is also magnificent, and performances are rare. Japan, but his long and high direction. This lowvalli has visited It's interesting to give new

music world who can clearly hear spatial information.

Schubert is a challenge from a genius in the early

Beethoven's complete symphonies first half and second half

released it in half, the demon of the early music world

Kosai, Ji "After Rudi Savard stood up to me and

conductor/orchestra that made another breakthrough.

Schubert's symphonies were recorded by a musical

Symphonies were recorded one after another, but

complete collection. The first of these was "Unfinished"

and "The Great". The latter is likely to become Savard's

The former's "Transfiguration" with Hand Soldiers

reverberations when interpreting Catalonia's performances.

the stone construction with its rich

SACD environment. As always, we are conscious of

microphone system while taking advantage of the

instruments. It was held in a church using a multi-

give the tone and elegance characteristic of period

part, with layers in the depth and height directions that

texture ensures the resolution and texture of each

Spatial information can be heard with ease. The delicate



Recorded: September 26-29, 2021 La Collégiale De Cardona, Catalonia, Spain

conductor's clear concept is interesting.

The long-awaited recording of the

The master Ivan Fischer is

he recorded this piece. Kurer wrote down the third movement

decided not to do so. Until he turned 10 years old in 2021.

celebrated his golden age at the end of the year, had

recording was completed, and the person in question, who

interpretation is still radical. Two months later, the long-awaited

into the inner workings of the work. However, the

explained that he tried to get rid of the extravagance and delve

The dynamic expression on his face is impressive. He

Szal, especially the Perspective Budapest recording.

interesting is that the important work was carried out by Jared

formation, and the same development is profound. What is

are placed in front of the conductor in the center of the

commentary book). In this part, the horn and Wagner tuba

make it sound more clear and emphasize it (see photo in the

of his 9th symphony, and he said that he wanted to

This is probably an expression of the performer's performance concept. Effect

Please check the disc to see the results.



Recorded: March 2021, Budapest, Hungary, Congress Center

acoustic space in the hall is also superb.

Recorded using a rare piano version. The

through the world of musical expression.

the unique part of 5 in free atonality, cutting

the piano. Originally, the soprano played

and is known as an innovative work that pioneers

E. Collaborated with other instrumentalists,

a new recording of their works. Soprano

Fuji and pianist Yumiko Mei have released

that holds it in the palm of your hand. Akane

Let's listen to a wonderful performance

Another highlight is the famous recording venue.

Saganiko Exchange Center in Kanagawa Prefecture, known as

dancing is light - the finest ambience of "Luxman Hall"

soprano, have a clear touch. The diction is clear and the

into the depths with the sound, and the soaring

suitable for this vivid work. The piano, which is sucked

this amount of information. The acoustic space is

enjoy on CD. It was intended. SA is advantageous for

This is a disc that I would like to



Recording: April 6-8, 2022, Kanagawa Prefecture, Yumiko Exchange Center, Luxman Hall

Ryoichi Hattori: Suzhou Nocturne



From here on: April 20-22, 2020, Henry Wood Hall, London

Piano Sonata No. 18 in E minor D769a (Fragment / ED994), No. 13

Schubert: Piano Sonatas

Stephen Hough (p)
(Tokyo M Plus PCDA68370)

performance that reveals the beauty of the work. A relaxed and in-focus recording with a heartwarming British pianist Stephen Hough not flashy, but the sound is carefully tasteful. old EM and Virgin eras. Last year was Warner. It's who can listen to early recordings from the his collections. He is a veteran recording artist relationship, and has released a 9-disc box set of from Hyperion, with whom he has a close has steadily built up a track record as a searist carefully captures the beauty of his works. He piano sonatas has been released that was done. Once again, a collection of Hubert's making for a heartwarming masterpiece. It at a well-regarded recording venue in London, the field, Henry Wood Hall. Hyperion was recorded tone policy of the instrument is one hall in his ability to strike an exquisite balance. The is a perfect example of this, and is known for The fresh pianism stands out. Schubert



Deutsche Kammerphilharmonie Orchestra, Bremen, conducted by Becca Kuusisto

Recording: January 26-27, 2022, July 9-11, Bremen, Kammerphilharmonie

Beethoven, Stravinsky: Violin Concerto

Wilde Frang (vn)
(Warner 9029.667740)

skillful sound processing and were performed beautifully. The two contrasting songs were pulled together by who steadily gained strength in Beethoven, contrasting artists, Vilde Frang, from Norway, violinist Becca Kusi. Stravinsky and two new recording of the Aiolin Concerto by fellow took on the challenge of recording a and nimble luck. He took over as conductor and response orchestra inspired lively excitement Bremen, the duo's keen sensibility and quick-dynamism. Co-starring with Itz Kammerfil The result was a performance full of information, and the sound is sharp and clear. Solo Colors are captured in rich spatial hard turn draws your ear to the surface, and the sense of speed just before it takes a the balance. The orchestra's spontaneous intonation fills the venue with great detail, it up. Rene, a veteran technician, adjusted Mellor is skillful in this area. I scooped



Recorded: April 1959 New York, Manhattan Center (RCA Victor Symphony Orchestra), etc.

Bernstein (ed. Mason): "West Side Torrey" selection, Bernstein (Bronne ed.): "West Side Story" Benizan (for violin and orchestra), etc.

Bernstein: West Side Story ~Dance Music

RCA Victor Symphony Orchestra conducted by Robert Russell Bennett, etc.

recordings of yesteryear. Awe at the engineer's magic. A hidden masterpiece connected to the excellent A collection of excellent recordings handled in 2022 Japan. A year ago, I had a chance to listen to it. Manhattan Center was "West Side Story," which was released on CD for the first time in Kondrashin's later RCA recording at New York's Orchestra recordings conducted by Stokowski, by Stokowski, and the Victor Symphony "Rhapsody." I think of the Russian ones conducted the excellent recordings such as West Side Stowe's of Lewis Leighton (Enley). When I think of beginning. As expected, I am reminded of the lineage exploding Businia). It's a masterpiece from the the surging air, and the magic of the brilliantly impact of the last and percussion instruments, this supernatural sound, the three-dimensional thickness and undulation of the strings that approached of telephonic woodwinds. I was awed by the I swallowed the words.

A stunning reconstruction of the rock poet's masterpiece. A masterpiece that combines musicality and poetry

A song by a rock poet alongside Dylan

Larry Klein, who is also a master of tribute work, has reconstructed the masterpieces of "The World" with great skill. Cohen's lyrics are wonderful, but there were times when I couldn't get used to his songs, but for this work, while respecting the late singer's full range of singing, he has hired a skilled singer who can get closer to the essence of the songs. The superb performances by jazz musicians such as Bill Frisell (guitar), who were chosen based on the concept of creating background music for the lyrics like in film music, are placed a little further back, while the vocals are placed at close range. Localization is clear and clear. It's a work that allows you to enjoy its wonderful musicality, but at the same time, it's an album that has a mysterious power that makes you feel as if you're listening to a raw poem being read. Without any disrespect, I think this is the birth of Cohen's definitive work, including his own album, and his greatest masterpiece.

Here It Is: A Tribute to Leonard Cohen

V.A.
(Universal UCCQ1170)SHM-CD



Bill Frisell (g), Immanuel Wilkins (as), Kevin Hayes (p, etc.), Scott Colley (b), Nate Smith (ds), Gregory Reese (pedal steel &), Larry Goldings (org), etc.

There are tracks with a sense of speed and sentimentality. A masterpiece with outstanding musical tolerance.

This is Toshhide's first new work in four

years, an electro-jazz-funk artist who was awakened by Buddy Rich and inspired by Jack DeJohnette to become a drummer. There's a feeling of being taken away, as if you're riding a roller coaster, but there's also a sentimental track that tickles a sense of déjà vu, like a high lamaze. You can feel the style of Brins in the way he fills in the sounds and cuts the rhythm. The album title seems to reflect the desire to focus on his own quality rather than the audience's evaluation, and this is an overwhelmingly pleasurable work with excellent inclusiveness that matches both with high revil. I'm surprised at how similar the track is to the solemn final song of Tatsuro Yamashita's *Sofly*, which I introduced in last season's issue, but I think it's true that both songs are very similar to the atmosphere of the times. This is probably a product of the depth of his delicacy.

quality over opinion

Lewis Cole
(Beat Records BRC710)



Sam Gendel (sax), Chris Fishman (p), Kurt Rosenwinkel (g), Nate Wood (b), etc.

written in gospel style A tearful melody and a vivid singing voice

written in gospel style

A new work by the legendary white songwriter who supported the backbone of soul music in the latter half of the 20th century. It's essentially — a joint project with Frank Cannon, who is also my current songwriting partner, and this time it's entirely gospel-style. Frank's accurate and versatile playing and engineering create Dan's tear-jerking melody line and heart-warming singing voice. Dunn's scale and rich vocals, which surpass those of professional singers, have diminished slightly with age, but his friendly delicacy and melancholy are still unique. The rare sadness that comes through each track full of flavor, such as the raw sound of "Out of the Blue" where he reveals his feelings as if savoring the words with only a transparent piano in the background, is a singer. This is probably the best moment in songwriter music.

Prodigal Son

Dan Penn
(Disc union OM033)



Frank Cannon (g, p, b, etc.), Jim Bullock (fiddle), Curzon Whitsett (p)

Detailed, deep, and crisp sound with gorgeous guests

Overwhelming at the top of the pop field

This is a new work by the legendary artist who takes full advantage of its potential, features plenty of luxurious guests, and is boldly dyed with house music. It goes without saying that the theme of the book is to break away from the gender binary, as well as to liberate yourself from all the "restrictions," regulations, and rigidity that exist in the world that are not natural to you, and to do so in a flexible and positive way. I'm appealing. Of course, the sound is so precise, dense, and crisp that it deserves a special rating, but it's not indiscriminately aggressive, but the sound structure is exquisitely relaxed depending on the attributes of the song. The glossy vocals, with a slightly nasal and pleasant mellowness, stand resolutely in the sound space. It's such a sublime piece of dance music that it's no wonder they immediately released a separate version of it, a remix of Madonna's "Vogue."



Renaissance

Piyonce
(Sony Music Labels SCP6483)

Beam (vo, ds), Grace Jones (vo), The Dream (vo, synth), Stuart White (ds, etc), Raphael Saadiq (b, etc), Nile Rodgers (g), Sheila E. (perc), Skrillex (ds), Tems (vo), Nova Wav (synth), Big Freedia (vo), 他

At 66 years old, this is a new work that gives off a feeling of being active. Buddy's roaring guitar cuts through

When I was 18 years old, I saw Buddy Guy for

the first time at a blues festival in Kyoto, and he was just a cracking guitar kid. Approximately half a century has passed since then, and this is a new work by the 38-year-old, the last great man to carry the blues world on his back. Once again, this production was produced by Tom Hambridge, who also handles the majority of the compositions, and includes a variety of rock-pop music guests such as Elvis Costello and James Taylor, appealing to a wide range of audiences. "We Go Back" with Mavis Staples (28 years old), whose name is also included in the Leonard Cohen dedication album, is a southern dish with the taste, richness, and aroma of JT. The style is also great. The band's sound is extremely dense and well-balanced, with Buddy's roaring guitar sounding like "This is distortion!" The tar cuts through the sound space.

The Blues Don't Lie

Buddy
Guy (Sony Music Labels SICP6492)



Jason Isbell (vocals, guitar), Elvis Coste (vocals), James Taylor (vocals), Mavis Staples (vocals), Bobby Rush (vocals, Harmoni CA), Wendy Morton (vocals), etc.

A memorial album based on pious prayers sung in a cheerful tone

In April of this year, at the age of 23, he will be missed and spend his entire life.

A memorial board for Tadashi Kosaka. Kosaka's 1975 R&B masterpiece "HORO" is a monumental piece in the history of Japanese pop music, but this work is the culmination of Kosaka's pure gospel songs created after becoming a Christian the following year. Kosaka sings innocent songs based on pious prayers to the Lord with a clear and cheerful tone unique to Kosaka. Although the musicality and sentiment differ depending on the production period, I am still strongly attracted to the soul-oriented works of the latter half. The best track is a new recording of "Hot Or Cold" from "People" produced by Haruomi Hosono in 2001. With a more urban and funky sound than the original, it returns to Kosaka's chic and profound style from the 1970s. I wanted to hear more and more songs like this, but thank you very much.

Chu's Gospel2022

Tadashi Kosaka
(Mikutam Records MCDN1159-60) Limited 500



Asiah (cho), Makoto Iwabuchi (vo, g), Sayuri Kume (cho), Daisaku Hisae (p, key), Steve Fix (b), Yasushi Ichihara (ds), Yuji Nakamura (b), Hiroshi Sakamoto (p, key), Hong Eiryu (g), Shigeru Hamani Toya (perc), coba (accordion), Euodia Ensemble, etc.

Recorded: 1982-2018

The second installment of Blue Note's reinterpretation by Toshihide, a prominent UK jazz musician.

UK jazz that you can't miss these days. This work is the second installment of "Plunaut Reimagined" (2020). This is a reinterpretation and cover of a classic Blue Note

Blue Note Reimagined II

V.A.
(Universal)
*Digital file (44.1kHz/24bit FLAC, MQA)

recording by Toshihide from UK Jazz. Japanese BIGYUKI plays Bobby Hutcherson's "The Creators." The finished piece is full of a floating feeling and a groove. The "Jazz" in UK Jazz is a slightly different style from what is commonly referred to as jazz, and refers to danceable music played by DJs in clubs. It's almost the same as the music called neo-soul in Japan. Norah Jones' "Don't Know Why" is a danceable piece in this film. The exotic sound of "Morning Side of Love" by Igo Ella May, a representative of the UK neo-soul scene, has a tropical feel, and the recording is extremely clear.



Igo Ella May (vo), Partenope (vo, sax, etc.), Oscar Jerome (vo, g, etc.), Ruben James (vo, p),

etc. Don't No Why, Morning Side of la V, The Creators, etc.

*SHM-CD (UCCM1269) available

The best players of today gather together to create the ultimate sound produced by perfect performances.

long gone

Redman, Mehlidau, McBride & Plaid
(Warner)
*Digital file (96kHz/24bit FLAC, MQA Studio)

The members of this album, including Joshua Redman (ts, s), Brad Mehldau (piano), Christian McBride (b), and Brian Blade (d), are all the best in the modern jazz world. The four members who came together as the Joshua Redman Quartet in the 1990s were active for only about a year and a half. This is because they are all outstanding and innovative musicians and are too busy. Approximately two years have passed since their last album, "Round Again," in which the four reunited for the first time in 20 years, has happily released their latest album. Mature talents bring their musical harvests together from their respective activities, creating a dramatic chemical change. The vivid and quick-starting sound is truly real jazz and is applauded. The sound balance of the performance is perfect, so you can enjoy the ultimate high-quality sound that will not fail even when played at high volume. It's Phi Sound.



Joshua Redman (ts, ss), Brad Mehldau (p), Christian McBride (b), Brian Blade (ds)

*CD (WPCR18500) available

A legend approaching the abyss of improvisation. The dense air gives you an incredible amount of heat.

Trios: Ocean

Charles Lloyd (sax)
(Universal)
*Digital file (96kHz/24bit FLAC, MQA)

Tenor saxophonist Charles Lloyd, the ultimate free-spirited legend, turns 26 this year! With a new project called "Trio of Trios," in which different trios perform on three albums, the first is 6. His second album, "Ocean," was released in September, and the third in January, showing no signs of slowing down. With this project, Lloyd explores improvisation even more profoundly and richly. "Ocean" is a recording of a live performance without an audience held in September 2020 at the Lobero Theater in Lloyd's hometown of Santa Barbara, a favorite of Pat Metheny. From the first song, "The Lonely One," the album has a dense atmosphere, as if adding energy to America, which is in turmoil due to the coronavirus pandemic. He is open-minded and has an incredible amount of positive energy. I want you to listen carefully to the harmonies that sway in the silence.

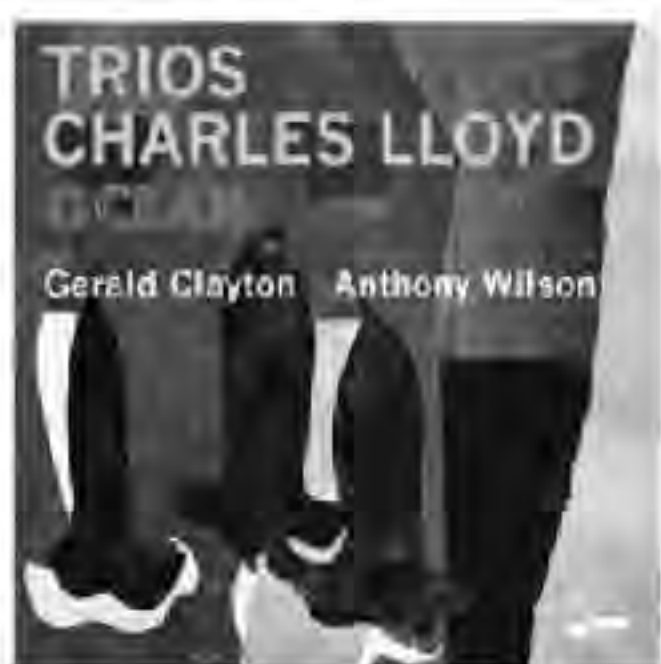

Gerald Clayton (p), Anthony Wilson (g)

*SHM-CD box set with "Trios: Chapel" and "Trios: Sacred Thread" "Trio of Trios" (UCCQ1178-80)

Sounds of Summer/The Very Best of Beach Boys (Expanded Edition Super Deluxe)

(Universal) *Digital file (88.2kHz/24bit FLAC, MQA)



Brian Wilson (vo, b, etc.), Carl Wilson (g, vo, etc.), Dennis Wilson (vo, ds, etc.), Mike Love (vo), Al Jardine (vo, dai, etc.)
others), others

2003 Masu works

*Remastered deluxe SHM-CD with 80 songs (UICY16072-4), remastered SHM-CD with 30 songs (UICY16075), etc. available

A new best-of album that is a must-have for enthusiasts. The lively roughness is also adorable. "Sounds" released in 2003. Of Summer/The Very Best of "The Beach Boys" was on the US chart at the time, selling over 4.5 million copies. To date, it has been on the monster chart for 104 weeks, it marks the 60th anniversary of the debut, and released. Although it is a best album, analog masters, and a new edition has been of these are mega-hit songs that remain on the 00s, which still has a lively roughness. All feel a slight hiss noise that is typical of the analog 26 songs are newly mixed, but you can't help but the first time. The most adorable feeling. This time, and two of the songs are stereo mixes for separated for the first time using new digital technology, enthusiasts. The original backing tracks are also a song that I played. This is a must-have for not. There is

art, vividly engraved with highly fresh sounds. An excellent work of

Revolver (special edition)

the beatles

(Universal UICY75227) LP *Direct import, complete production limited edition



John Lennon (Vo, G, etc.), Paul McCartney (Vo, B, etc.), George Harrison (G, Vo, etc.), Ringo Starr (DS, etc.)

1966 work

*SHM-CD 5-disc Super Deluxe Edition (UICY80210) Various specifications available

as "Sgt." The Beatles released smoothly. A number of Limit 50th anniversary albums such "Revolver" and "Peppers ~", "Abbey Road and Giles Martin, who also did the book for (this time it was written by Demick Sam O'Keefe released in October and does a really good job half-speed cutting). The one I got was pitched sound of "Rubber Soul." Also utilizes carving it on vinyl records, recorded the high-Beatles during their early years by vividly Showell, who freshened up the music of the band. The Beatles even "Rubber Soul." Miles the true artist is an outstanding rock'n'roll an excellent work of art, but in this "Revolver," Transformed into a postist. "Revolver" was that it brings back an extremely fresh sound. The bass sound played by Ruber is so shocking it's so vivid and dynamic. I'm surprised.

on SACD to commemorate the label's 50th anniversary. A masterpiece of sophistication and melancholy released

Flight to Denmark

Duke Jordan Trio (Tower Records SCSA1001) SACD 2ch/CD



Recorded: November 25, 1973, December 2, 1973

Copenhagen, Sound Track

Duke Jordan (p), Mads Vinding (b), Ed Thigpen (ds)

the world's first SAC Tea Bull Chase anniversary of the founding of selected titles commemorate the 50th Hardbuke Jordan. 10 carefully model with the jacket photo of Airbub. Iconic. Steeplechairs will excellent works by Copenhagen's However, this album also includes many sophistication and melancholy. piano, Mad's Vin feel, and the where you can feel Bayodan's neat years ago. This is a masterpiece hard to believe it was recorded 50 Winter's sound is so spot on that it's truly "jazz-like" sound. Producer Nils reproduced it so well. DSD has a I'm glad that the conversion

Famous recording

deep

Kenlaro Takahashi



butterfly

STEREO SOUND 442

The year 2022 will mark the 40th year since the first CD was released. The world's first CD is Billy Joel's "52nd Street," released by CBS/Sony in Japan on October 1, 1982. CD was released, but the one with the youngest product number and the first to hit the production line was the New York CD.

Serialization 35

The A&R studio where Ramone was based has been mentioned several times in this series, but the photo of Billy that adorns the jacket of "New York Street" was taken on the street in front of the very studio. The decision to produce "New York Avenue" as the world's first CD was made by Japan's CBS and Sony.

Ramone's pursuit of a sense of tranquility

It may have been the result of Phil's Alba produced by Ramone. It is inevitable that it was

Precise recording techniques and sound creation

It came to fruition beautifully

"Second Childhood"

It was the world's first CD. It is certified as D. This album by Billy Joel was recorded at the A&R studio on Figure Avenue in New York. Googled. Engineer/Producer Phil

C appeared in the company's advertisements. Seeking to rise from the silence, Ramone turned to Dolby Noise Reduction, which reduces the hiss and hum of analog tape recordings and increases the signal-to-noise ratio.

Similarly, the medium known as analog records had problems with the signal-to-noise ratio. In addition to the hum and rumble noise produced by turntables, there is also the inevitable noise of the stylus contacting the surface. The CD, a digital medium that appeared in 1982, was still far from analog records in terms of sound quality, but it was overwhelmingly superior when it came to the SV ratio. There is no doubt that Ramone was intrigued by its quietness. When you think about it, "New York Avenue" became the world's first CD title. It makes sense that he was chosen by Toru. "New York Street" was released on analog record in the afternoon of 1978. Along with 1977's "Stoninger," this is Billy Joel's masterpiece. Phil Ramone's other albums from this period are also masterpieces. The most famous one is the Grammy Award, which Restides Album of the Year and Paul's winner of the Grammy Award. Simon's 1975 Still Crazy After All These Years, Art Garfunkel's Breakaway, David Sanborn's 1976 "Sanborn" (Japanese title: Mellow Sanborn) and Libby Titus' "Libby Titus" in 1977, which I listened to from a young age and were influenced by.

三半

Phoebe Snow's second album "Second Childhood" was released in 1976. The photo shows the domestic CD (Sony Music Japan SICP3209, limited edition) that was DSD remastered in 2011.



It's an album.

the one album I have the most fond memories of is the album "Second

Childhood" released by Phoebe Snow in 1976. "Second Childhood" is the best way to appreciate the quality of the A&R studio and the precision of Ramone's production. With this in mind, I have continued to keep records and CDs close to my audio system for over 40 years.

The arrival of a

terrifyingly unique singer

Phoebe Snow is a singer-songwriter born in 1950. A native of New Jersey, he began singing at clubs in New York's Greenwich Village in the early 1970s, with a guitar in hand, and was witnessed by Dino Airari, head of Shelter Records, in late 1972.

Shelter Records was founded in 1969 by Denny Cordell and Leon Russell, and had enjoyed moderate success, releasing albums by Leon Russell and J.J. Cale. Denny Cordell is an Argentinian producer who built his career in the British rock scene. Leon Russell was a talented pianist in the Los Angeles studio scene, but his 1970 solo album Leon Russell made his talent as a singer-songwriter known to the world. Shelter code is Los Angeles

He had an office in Els and a studio called Church Studio in his hometown of Tulsa, Alabama.

Phoebe Snow was discovered by advertising manager Dino Airari and signed to Shelter Records. Moved to Los Angeles and began preparations for album production. At first, they seemed to be experimenting with folk-style recordings at Church Studio with Denny Cordell, but at Dino Airari's suggestion they decided to add jazz musicians to the album. He continued recording in Los Angeles and New York, and completed the album at A&R Studio with Phil Ramone in charge of mixing. Legendary pianist Teddy Wilson, saxophonist Zoot Sims, and keyboardist Bob James

The New York session, in which participants such as it seems that Ramone was the one in charge.

Although it was an album released by a completely unknown newcomer on Shinko Nobel, the debut album "Phoebe Snow" released in July 1974 gradually gained popularity, and the single

"Poetry Man" was released. rose to number 5 on the US charts the following afternoon in May. Album sales exceeded 1 million copies, and it was a huge success for Shelter Records. I also bought this album when I was in college. Interestingly, however, the title of the Japanese version was "San Francisco Bay Blues," and the jacket featured images of San Francisco's Bay Bridge, which the original version did not have. For a while, I thought that Phoebe Snow was a singer from San Francisco. As of this debut album, Phoebe Su Nou was already an incredibly unique singer.

PHOEBE SNOW



"Phoebe Snow (1950~2011) (Japanese Debuted in 1974 with the album title: San Francisco Bay Blues)" (pictured). His guitar and singing voice attracted attention, and the album became a hit.

The range is wide and thick. He uses everything from a low voice to a delicate falsetto. Most importantly, it has a characteristic large-amplitude vibrato. To be honest, I don't like singers who sing with vibrato, but Phoebe's vibrato is an exception. At this time, Phoebe was still in her early Twenties, but her singing

voice was detached and had a mysterious atmosphere.

It was even full of water.

In addition, her acoustic guitar was also unique.

It seems to be based on country blues finger

picking, but uses strange chords here and there.

The ultimate example of this is the huge hit "Poetry

Man." If you listen closely, you'll notice that it's

a two-bar blues-like song, with chords that change

in tension from moment to moment, and a

melodious melody. The music is so mysterious that I

can only describe it as the music of Fubi Snow.

Masterfully produced and

recorded by Ramone

"Second Childhood" was Phoebe's second album after her debut album, during which time she

experienced some trouble in the music industry. Surtale

My relationship with the code was strained.

Phoebe attempted to terminate her contract with

Shelter Records, citing lack of remuneration and

album promotion. However, Shelter Records

sued Phoebe and CBS/Sony, who were trying

to sign her. For this reason, Fee had to take

it a break from activities for a

while. The debut album featured co-producer Ku

seems that Phil Ramone, who only received

a credit in 2007, was ready to throw his full

weight behind Phoebe's album. Phoebe appeared

as a guest on Paul Simon's "Encoding the Passage

of Time." "Gone At Last" was released in

August 1975 by Paul Simon and Phoebe.

Since it was released as a single under Snow's

duo name, the dispute with Shelter Records

must have been resolved around this time.

Then, Ramone took charge of "Second Childho".

↳ This production will proceed.

For Paul Simon's "In the Passage of Time", Simon

was not familiar with jazz musicians, so he reportedly

relied on Ramone to arrange the musicians, and the

production of Phoebe's "Second Childhood" was

also an extension of this, there were. Top New York

musicians carefully selected by Ramone participate

in each song. The drummers are Steve Gadd,

Grady Tate, and Jimmy Young. The five bassists

are Tony Levin, Ron Carter, Will Lee, Gordon

Edwards, and Richard Davis. The rhythm section

alone is such a lineup that you'll have to worry

about it every day. Keyboards: Richard Tee, Don

Grolnick with Hugh McCracken on guitar

When you write about John Tropicay, some people might think that this is an album colored by the jazz-fusion sounds of New York at the time, but the production of "Second Childhood" does not fit into that framework.

That's because Phoebe's mountain-building and singing voice are studio-mixed.

This is probably because he had a unique personality that didn't allow for the usual backing of music. The first three songs are an ensemble centered around acoustic guitar, giving a sense of continuity with the previous work, but even the songs centered around a dynamic rhythm section and the songs with large orchestrations are just as good as Phoebe's. The music maintains a unique, mysterious atmosphere. The performance of the session musicians is wrapped up in the mood, never going beyond what is necessary. It's not noticeable.

Orchestras used for this Ramone album

La arranger was Bat Williams. Williams was

a successful arranger in the world of film music

and had a shot at Hollywood, but Ramone

enlisted his help when the time came. In "Second

Childhood," Williams' orchestration, sometimes

reminiscent of a jazz big band and sometimes film

music, colors the five songs. I don't know

if they invited Williams to New York or if they

just sent him the score, but the orchestration was

also recorded in the not-so-large A&R studio.

It seems that it was

done in The fifth song, "Sweet Disposition,"

features a wonderful horn ensemble, but this

one is by tuba player Howard Johnson. David

Sanborn plays the opening saxophone solo.

"52nd Street, New York" Billy Joel
(Columbia 1978 work)

This album, said to be the "world's first CD," was produced by Phil Ramone, following the release of "The Stranger" in 1977.



However, for the rest of the lively horn part, Johnson plays five tubas on top of each other by himself. Looking at the credits, there are only six musicians playing. This is a song that shows the true spirit of Phil Ramone's recording techniques, placing only the necessary sounds and expressing richness with an acoustic atmosphere.

Although she didn't have a hit song like "Poetry Man," Phoebe's seven original songs were full of deep flavor, and the three cover songs also gave a sense of Phoebe's musical depth. The fourth song, "No Regrets," is from the famous 1930s mountain song sung by Billie Holiday, and the last song, "There's A Boat That's Leave in' Soon For New York," is from the George and Ira Gershwin musical "Porgie," also from the 1930s. &Beth", but Phoebe sings it with her own interpretation without responding to either of them. Another cover is track 8, "Goin' Down For The Third

The song is arranged as a slow funk tune reminiscent of the 1980s and Little Feat.

A well-thought-out album with rare sound quality

relationship between Phoebe Snow and Phil Ramone continued after this, and in 1977, Phoebe recorded ng Go (Japanese title: The Scent of Rose Huai) was entirely recorded at an A&R studio, but each song is as well thought out as "Second Childhxxxl," and the production is such that even Steely Dan would be impressed. The elaborate album was never made. The a record with Billy Joel's album Never Letti.

He appeared as a guest on Rubum's "The Stranger," and there are some interesting episodes left at the A&R studio at that time. At that time, Billy was still a singer-songwriter who had not yet had a hit, but Fubi was a star who had already experienced million-hit hits. As the album neared completion, Billy was unsure whether to include the pop song "Just The Way You Are", which was too sweet for his previous style. Phoebe and Linda, who was good friends with her, were there.

Convince Billy. As they predicted, from the album

The song was released as a single and sold over 2 million copies. It became a monster hit.

"Just The Way You Are" featured a saxophone solo by Ramone's old friend Phil

Woods, but the idea was actually first used by Phil Woods on "Never Let Me Go." Ta. If Phoebe Snow hadn't been a regular at the A&R studio at some point, the superstar Billy Joel might never have been born.

Although it did not sell as well as their debut album, [Second Childhood" sold over 300,000 copies in the US and yen, and was awarded a gold disc. For this reason, it is not difficult to obtain original LPs even today. The Japanese LP released by CBS/Sony under the title "Yoru no Choke" is also often seen. However, the works produced by Phil Ramone may be better heard on CD. Ramone left an autobiography in 2007 called [Making Records], and on the front and back covers there are photos of stacks of CDs he made. Among the "Second Childhood" CDs, the one with the best sound quality is the limited edition produced by Sony in 2011, which has been remastered in DSD. It may be difficult to obtain.

Phoebe's debut album is currently being sold as a DSD download by EMI, and since "Second Childhood" has also been remastered in DSD, I hope they will release an SACD or sell a DSD version as a download. That's what I want to do. After all, there aren't many albums that sound this good.

released in 1967 by the Supreme.

mus hit songs

But what is the original song?

Far away, Meeta



Ronstadt came to visit. Billy is the Girlfriend Phil

Are," they both agreed that this song was definitely going to be a hit.



Serialization,

Famous songs stain



Ru



Shinichiro Kobayashi

In the last issue of this magazine, I introduced Tatsuro Yamashita's latest work "Softly" in the new album review column. This is a collection of sublime love soul created by a man who has continued to dominate the streets by absorbing the sensibilities of the times and expressing his own passion. It is a unique masterpiece that makes my heart bloom no matter how many times I listen to it. is. Although I didn't mention it there, the first edition package comes with a bonus edition of the acoustic live concert held at Tokyo FM Hall in December 2021 in addition to the regular edition (2022). Still available as of December 1st). For someone like me who has enjoyed his music for a long time, this bonus edition is far more than just a bonus. Contains seven outstanding pieces from his repertoire from the first half of his nearly half-century career ("Pando", "Pocket Music", "Turner's Steam Novel", "Sweet Dangerous Scent"...).

This live performance will be performed by Nagano, a member who has supported him. Trio with Hiroyuki Nami (4) and Hironori Ito (b) Yamashita's spin-off project with performances Started in 1993. now his debauchery It can also be called a life's work. years

It is aged over and over again, and the flavor components are added.

#35 Paper Doll Paper Doll

Tatsuro Yamashita's musical thoughts Sung for 40 years The essence of sweet funk

Although I made it as a single song in order to sell it somehow, the record club The company rejected it. Despite this, "Paper Doll" is sung through the ages and handed down from generation to generation "It's a Poppin' Time" (1978), which was the first appearance of The tension and musical richness are highly balanced. I can't believe it's a live album You will be surprised by the rich texture. The take for the original single is included. 'Go Ahead!

Due to my personal view of the end, I could not make any progress in composing wings, and ended up using some provided by others or covers.

There are many, and you can enjoy Yamashita's comprehensive power as a music creator. Such Yamashita The show opens with "Paper Doll" by Akiko Yano, whose artistry is captivating. "Home Girl Journey" (2000) is a collection of the charms of a variety of famous songs. An amazing collection of piano songs to dissect. Yamato's latest work "Soft Lily" -(Moon Warner WPCL13359~60, first edition, 2022)

"Paper Doll" has been around for half a century, including the re-performance of Iwashii. On the special edition of

Overwhelming performance by each and every player a call-and-response style, and unlike on a full-fledged tour, their songs and performances were relaxed and intentionally did not raise the temperature, but each track had an analysis that could only be created by these three. A gentle groove was revealed, which further stimulated Yamashita's groove as a vocalist, allowing the audience to enjoy a musical masterpiece that can only be described as mellow. Wear.

Among them, "Paper Doll" is particularly moving. Reviews of his solo debut, "Circus Town" (1976), followed by "Spacey" (1977)

For some reason, sales were not good, and as expected, the He carefully composed the song, realizing that he needed a vocalist, and bravely recorded it in 1938. However, the record company dropped the song, saying it wouldn't sell. However, Yamashita's next album was decided to be a live album, as he was also focusing on his live house activities at the time, and as a result, "Paper Doll", which had been performed live, was replaced by "It's". "A Poppin' Time" (May 1978) saw the light of day as one of the songs. In addition, although it was shelved as a single, the original studio recording was included in their fourth album, Go Ahead! (December 1978), which they approached with the determination that "this might be the last time." It was.

In the studio version, Manabu Yamanaka's sturdy bass, Yutaka Uehara's drums, and Yamashita's bending guitar suddenly create a syncopated unison sound, and the intro is just a bouncing rhythm. Start. Even after the song begins, it continues with this irregularly syncopated 16 beat, and Ryuichi Sakamoto's clavinet adds a funky blow through the gaps in the rhythm development. Of course Yamashita's Yusuke and emotional soul Lufuru's extremely unique vocals are outstanding

In groups, use white meal as paper dolls.

A timid man's fragile love

A mountain-colored word in depicting

Sweet Sow

A waka-verse that can be said to be the essence of La

branch. At that time, this was so thorough.

Pursuing the musicality of

Feel the overwhelming groove

In our country, the songs that make

I couldn't find it for a while

And that musical depth is

I too think it's true

Felt. However, Kayo Yamazen

The era of prosperity continued for a long time, and

Kohe Group Sounds

Even though it was a time when

new music, starting with

folk music, had already become

popular after its baptism, there

is little chance that the general

public would be able to grasp

the cuteness that lies behind this

powerful musical blow.

Yamashita, who says that he created

it in the context of Chicago

soul, probably had his own anticipatory logic

as a single song, but it may be a bit too highbrow

for a single. However, such single-mindedness

and thoroughness are Tatsuro Yamashita's

raison d'être, and that is why he continues to

work as a creator even now, at the age of 70.

continues to evolve as a



Jazzy performance

on electric piano

with a spacey tone.

Since the venue is

Roppongi Pit Inn,

the whole thing has

a very strong jazz

fusion feel to it.

Both tracks are precise,

strong, and

highly complete, which

is also typical of

Yamashita's

uncompromising nature.

-I don't think of trying.

(Usually...).

But those 22 years

After that, a surprising surprise.

A cover appears.

<Tatsuro Yamashita's "Pathetic"

Akiko Yano declares that she

likes "boy's songs". For the

time being, she has

completely replaced Kawado's

original composition, which

is also a tight-fisted funk soul song. On top of that,

he sings in a murmured manner, adding a subdued

piano note or chord to accompany the phrase.

The beauty of the song is truly unique, and its

exquisite perfectly depicts the sadness that is

unique to this song. However, the interrogation

part is an impromptu piano solo with a jazz feel.

Boldly delving deep into the music and raising the

dynamics of the track. Listening to it, it seems that there

is no trace of the original punishment, but there is

nothing strange about it at all, and with a wonderful beginning,

water, turn, and conclusion, by the end, the piece

enters into a dramatic emotion that is exactly the same

as Yamashita's original. Invite the listener. This is a gold

masterpiece that depicts the essence and drama of

Harayama on the wall in a completely original manner.

It is.

Betting my fate as a record singer

The live take was rejected even though it was well

received, and it barely made it to the world as

one of the songs on the live album, but even so,

it had one of the best grooves in Shirami's work,

so I was prepared for this to be the end. The original

studio take included in the fourth released work,

And Akiko Yano's amazing kava two years later

- and a clear and mellow acoustic version

by the Tatsuro Yamashita Trio a year

later. Comparisons in this area are

somewhat in the realm of maniacs, but in the

world of jazz, this kind of deep enjoyment

is something to be ashamed of, and the

depth of carving and detailed world view

that is more than worthy of that is what is

considered a "paper per". Dole is available. I

repeat, this is a piece of music that most

concretely expresses Yamashita's unique musical

strengths, despite his pathetic wording.

Diinkt symbolizes the wood quality of

I think it's a masterpiece.

Series 15 There is a reason for famous songs Atsuya Matsuki

Wagner: Opera "Tannhäuser"

If we define a masterpiece as a musical work

that has been accepted by many listeners, then "ease of understanding" would be one of the important conditions for a masterpiece. The opera "Tannhäuser" is truly "easy to understand" at first glance. The stage works left behind by Richard Wagner (1813-1883) are all far-flung. Regardless of the overture or prelude, if you're on the fence about the complete composition, it might be a good idea to start with Tannhäuser and Wartburg Lied (this is the entire title), do not have.

First, let's listen to the complete version of the Berlin Radio Symphony Orchestra conducted by Marek Janowski, starting with the overture. The body is a simple part format that unfolds as A, B, and A. A is very solemn music in 3/4 time, while B (disc 14 minutes 18 seconds) is a contrasting piece of music in 2/2 time, full of bright and lively movement. A (10 minutes 22 seconds) corresponds to the reproduction part of A. This is pretty clear just by looking at it, but it becomes even easier to understand if you look at which scenes in the opera the music material used in each part is connected to. So let's take a quick look at the story.

I want to keep it

The story is set in the Thuringia region of Germany during the Middle Ages. On one side is Wartburg Castle, where the upright knights of song live, and on the other side is Venusberg, with its underground pleasure chambers. Tannhäuser, also a poet knight, stayed in this basement for many years. Unable to bear being a slave to his lust any longer, he shakes off the restraints of Venus, the female master of paradise, and returns to Wartburg Castle on earth. However, the knights here only praise platonic love in a singing contest under the theme "What is love?" Tannhäuser is irritated



Richard Wagner (1813-1883)
Portrait circa 1842 (Classic Image / Alamy Stock Photo)

The cover of the 1845 first edition of the score used for the premiere of Tannhäuser



A painting depicting the first performance of "Tannhäuser" (Lebrecht Music & Arts / Alamy Stock Photo)

The top is decorated with young leaves, led by a bag and Become:

In other words, miracles occur through God's grace, higher height. Sexual love (Eros) is pure love (A) verse, and through the passage, it was lifted to a foreshadowed such a conclusion as early as the first reproduction of A. This is because the overture A, which is the third part, sounds like it is just a A, and only changes after passing through B. The time signature is no longer in the quarters of triple meter at A, B It's from 2/2 beats of.

music at the end of B, and without returning to the pilgrim descending thorns that were in the background of the melodious

triple meter (with a rest in between) continues the

a doublet, which was a favorite among the listeners. The The synthesis of eros and agape has been rewritten as Might happen.

But it is. Will the opera "Tinnhäusa" be performed? completely impressed by this "easy to understand" design.

"Is this work salvageable?" was

Tannhäuser's salvation and

Wagner's argument:

Wagner's dramatic musical works theater had not even been conceived. theater in 1876, at a time when the

(1876), which was built as Wagner's work of the Bayreuth Festival Theater of the same play. Tannhäuser was the fifth Kapellmeister, and this work is also part

In 1845, he held the position of He himself conducted the premiere.

2010, when the composer was in his 80s. It is about.

performance, the work began to follow the final revised many times, and as early as after this first were finally settled down, and the scenes were is generally known as "Dresden." In 1860, these figures as a "Paris edition" based on the afternoon manuscript. This performed in Paris in 1861"). It was later published the Dresden version (sometimes it is called "the version This does not reflect the reality of consistently performing I want to.

first of all, let's talk about Tannhäuser. the person saved?" To answer this question, We need to think about the question, "Was



Robert Dean Smith (T. Tannhäuser), Nina Stemme (S/Eli)
 Marina Brudenskaya (Ms Venus), Berlin Radio Symphony
 Orchestra & Chorus conducted by Marek Janowski
 Recorded: May 5, 2012 Berlin Philharmonic, Berlin
 [Pentatone PTC5186405) SACD Multi-ch SACD 2ch CD *Imported disc,
 Currently out of print. However, it can be listened to on Sharaku distribution services such as Spotify.

It will be. Wagner Mountain Body was created in 1853. In his letter he says: "What I

wanted to clearly show in the new ending is that Tannhäuser is not saved by the church, which expresses his sins, but by the infinite love of a woman (no matter what the church says)." That is to say, the priest's rod only sprouts through the sacrificial death of Elizabeth. That rod disowns the Church."

In other words, the priest's rod buds forth only through the sacrificial death of

Elizabeth. Elizabeth prayed earnestly to the Virgin Mary for forgiveness, and her love came true.

However, after hearing this, Tannhäuser claims that he has been saved.

Is this true?

break the taboo

repeated out-of-place statements

Tannhäuser's words and actions leading up to the end.

When you look at the music, he says, "This is it! over and over again.

Sometimes he makes the most inappropriate statements. First is the Venusberg scene in

Act 1. Twice he praises the love and pleasure that

Venus has given him, and each time he begs, "Let me go!" and finally exclaims, "My salvation is

in the Virgin Mary!" (Janovski disc 1 6 2

minutes 2 seconds). Venus is a former Germanic

fertility goddess who was seen as a demon of perversion in Christianized society and was driven

underground. Maria's name is the last name she wants to hear.

And in the second act, the knights of Wartburg Castle

After provoking Tara three times, he finally declares, "You poor people who have never tasted love,

go to Venusberg!" (200 minutes 3 seconds on the same disc). For the residents of this

castle, such as the Moral Society, the virtuous Wolfram says, "O Lord, exorcise sin from this noble and

innocent place!" "Venusberg" is a mouthful. It's a taboo to even do it. It's a small taboo. Moreover,

the first half of "Tannhäuser's Bomb Departure" is the same melody that he sang in praise of

Venus in the first act. We, the audience, are even more surprised than the residents of the castle.

The surprise is the orchestra that rises to the melody. A's completely unreasonable modulation, which

is like speeding up a tape, will probably double your chances (at the end of the same episode).

23 E flat major to #4 E major. Considering that the Venus story in Act 1 went up by a semitone

in D flat major, D major, and E flat major, Tannhäuser now reaches E major and moves up another

semitone. So, it can be said that the voltage of taboo breaking is increasing even more.

No, he doesn't want to break taboos and have pleasure. He makes statements that are out of

place because he sees the current situation where people are completely satisfied with one set of

norms and values, and he can't stand it. It is doubtful whether he is seriously seeking the

Virgin Mary or Venus each time. For him, the question of choosing between lust and abstinence

does not exist; if you want pleasure, you want pain, and if you want pain, you want pleasure.

is his desire

Yes, it's a "problem"

Noda.

Therefore, opera

«Tannhäuser»

is added to sexual love

A sinner is saved

Whether it will be done or not

That's not what I'm talking about.

The current situation is radical

continue to refuse

If so, isn't this the story that there is no choice but to be destroyed on this earth?

An opera of "denial of the status quo" with

contradictions and discrepancies intact

--When I look at it this way, I turn to Wagner and say, "Maybe he is misleading us into

an easy-to-understand story of salvation?"

I am afraid and have many doubts.

"This work is a little more complex, and I think that's what makes it so appealing."

There is a character in the play who feels some deep

sympathy for Tannhäuser, who seems to have been painted in stone. Yes, this is Elisabeth, the princess of

Wartburg Castle. Act 2. She sings to Tannhäuser, who has been reunited with him for the first time in a while,

feeling nostalgic and not knowing that he was in

Venusberg the other day.

"I have listened willingly to the

clever songs of other singers;



Torsten Kerl (Tannhäuser), Camilla Nylund (S Elisabeth), Michel Breed (Ms/Venus),

Bayreuth Festival Orchestra conducted by Axel Kober Group & Choir

Recorded: August 12, 2014 Bayreuth

(Opus Arte OA CD9044 D) *Imported edition

STEREO SOUND 450

The way they sang and the praises seemed to me like some sort of elegant play. Your song, on the other hand, has awakened new life in my heart! Sometimes it was a pain that made my body tremble, and other times it felt like unexpected pleasure." (disc 24 minutes 10 seconds)

Sometimes it's pain, sometimes it's pleasure. Elisabeth's vocal style, which supports Tannhäuser's songs, which is a clear departure from "elegant play" and does not rest on the standard, is also a pleasure to listen to. The beginning with the accompaniment of dispersed chords by the strings is very much like a prisoner's opera, but when it reaches none other than "Sometimes it becomes pain", the key, rhythm, and articulation become inconsistent. (Viola writhing!) A sense of urgency flows through her (4 minutes and 2 seconds).

It is a characteristic of "Tannhäuser" that it injects music, sometimes to the point of forcing, into easy-to-understand causes, and it cannot be said that this work is primarily an opera that "denies the status quo." Whether seen as a story or as a piece of music, the story of the old man and the departure of the masters in this work are neither subdued nor integrated until the very end. Some say that "Tannhäuser" has not yet broken out of the tradition of "opera," or that it already contains the germs of later "opera." The third act, Tannhäuser's "Roman", is invariably cited. "Mother's Story" (Discs 38-10), and the gaze from our side that wants to categorize us. Better reconsider.

As for Elisabeth, her tragedy lies in the fact that she tried to save Tannhäuser, who was on the verge of destruction, by imitating the passion of Jesus Christ. She committed suicide while praying to Mary. Wagner may have thought that he saved Tannhäuser with "true love" that was willing to die, which was different from the authority of institutionalized Christianity, but if he viewed this "sacrifice death" as too god-like, which could also develop into some kind of institutionalized religion. Elisabeth, who showed understanding to Tannhäuser, was, so to speak, killed by society. Similar to the case of Jesus. To say that "Tannhäuser was saved" might be to overlook this murder. Don't be fooled by the chorus singing loudly about God's grace.

Of course, this one has good proportions. In the so-called one-Paris version, it takes too long for the first act and Tannhäuser to get out of Venusberg. On the other hand, the climax of the second act, the singing contest, was shortened. For this reason, I would like to start by listing discs that conform to the "Dresden Edition." The Janowski board that I have been referring to is a combination of screams and orchestra are incredibly precise. Are there any realists who view this as "impossible" in light of the content of the play? For such people, we recommend the live album from the Bayreuth Festival, conducted by Axel Kober. There are just the right amount of miscellaneous elements, such as the chorus of pilgrims, and it feels "realistic", and Camilla Nylund, who plays Elisabeth, is wonderful. The Franz Konwitschny edition, produced at the Berlin State Opera during the East German era, is quite old-fashioned in style, but the songs from yesteryear are valuable. The "Paris version" was performed by Sir Georg Solti.

There are various reasons why I want to adopt the "Dresden version".

The Vienna Philharmonic conductor's version is still the best.

Enjoy the charm with different musical

scores and performances



Hans Hopp (T/Tannhäuser), Elisabeth Grümmer (S/Elisabeth), Marianne She Hi (Ms Venus), Berlin National Song conducted by Franz Konwiczny Theater Orchestra & Chorus Recorded: October 17-21, 1960 Berlin, Grunewaldkirche (Tower Records TDSA187-9) SACD 2ch CD *Limited edition



René Collo (T/Tannhäuser), Helga Demesiyu (S/Elisabeth), Christa Ludwig (Ms/Venus), Sir Singing of the Vienna Philharmonic Orchestra and the Vienna State Opera conducted by Georg Solti Recording: Vienna, Sophiensaal, October 1970 (Universal 483-2507) *Import first limited edition, current Out of print. However, digital files are available on e-onkyo music, etc.

Wartime recordings conducted by Furtwängler now available on LP record.

Among the many independent labels for orchestras, Berlin Phil Recordings' activities are by far the best in terms of both quality and quantity. An SACD CD hybrid disc based on the recordings of the German Reichsbroadcasting Corporation, based on the performances by the legendary mountain master Wilhelm Furtwängler (1886-1954) from 1939-45 during World War II. The 2-disc box set (originally released in 2018) is one of the monuments.

The history of this broadcast recording is extremely dramatic, from its post-war requisition by the Soviet military to the return of the copies and the discovery of the master tapes.

This season, the Berlin Philharmonic has selected songs with excellent performance and sound quality from this box and rearranged them into an 8-disc analog LP set. The sound source is the same as the SACD, the cutting is done by Emil Berliner Studio, the punch is by Pallas, and the disc is 180 grams. It comes with a DVD with footage from Furtwängler, a download code for the digital file (22 bits), and a 112-page instruction manual. Limited to 2000 sets. Included works include Beethoven and R.

Recorded between 1942 and 1944, mainly featuring songs that were the core of the upper repertoire, such as Rouss and Wagner. A newer sound source with favorable physical conditions was chosen. The arrival of the actual item was delayed due to the deterioration of the logistics

However, just as the deadline for this article was approaching, a test board came along. I immediately tried listening to it on my analog playback device (exclusive P3a + D S Audio DS003 cartridge). The disc quality is good, with little surface noise.

There are several types of sound sources depending on the mountain, but the one in the best condition is the Lophilharmonie performance, which was created directly from the original tapes of the German Imperial Broadcasting Corporation. Although it is an old monaural recording, it has a magnificent acoustic feel, and in some mountains you can clearly hear the outline of a harp or glockenspiel. In Beethoven's Violin Concerto (January 1944), which is said to be Furtwängler's last performance at the same venue that was lost in the war, Erich Lehn's solo performance stood out in a brilliant manner, and the ears were awestruck. I was transfixed.

Furtwängler was still in his fifties at the time, male



Scheduled to be released in mid-December

German Imperial Radio 1939-1945
Conducted by Wilhelm Furtwängler
berlin philharmonic orchestra
(King International KKC1201-8)

8LP+1DVD
Regular price: ¥46,000 (tax included)

*Limited edition. SACD box "Furtwängler" Imperial Broadcasting Station Archive 1939-45 (KKC5952-73) High-resolution files of all recorded sound sources (48kHz/24bit) · Download code included

Wilhelm Furtwängler, wartime 1939-1945 - and numerous concerts by the Berlin Philharmonic Orchestra, was recorded and broadcast on the radio. These recordings were made in 2018 22-disc SACD/CD hybrid edition (King International) It has already been released in the form of Naru KKC5952-73), but now A selection of concerts will be released in an 8-LP box set. It will be released as a. This set includes Furtwängler's valuable A DVD containing a documentary with footage is also included.

flat expression

You will be overwhelmed by the energy of the performance, as Shirazai and Hakuzai play energetic leads that make full use of agogiku. The record of the concert, which took place as the war situation worsened by the minute, has a somewhat tense atmosphere. DS Audio's optical cartridge, equipped with a new power generation mechanism, is

I vividly captured the presence and tension. The LP set seems to appeal to the listener's emotions even more than the digital disc, revealing the essential value of a historical document with a strange fate. This set is a must-have for audiophiles who understand the essence of musical art.

Esoteric SACD masterpiece reprint series

Hiroshi Miyashita

SACD reprint of Alban Berg Quartet conducted by Bernstein, Gergiev, and Böhm

Esoteric's masterpiece reprint series, which carefully produces historical recordings that will remain in performance history and releases them on SACD/CD hybrid discs, has released one classic piece this season. The lineup includes three labels, three digital sound sources, and one analog sound source. The entire process was carried out at the Esoteric Mastering Center, which was built in-house and utilized the company's high-end equipment and know-how. Release date is December 10th.

From a Deutsche Grammophon (DG) recording will feature two great performances by the Vienna Philharmonic. Mahler 1's Symphony No. 5, conducted by Leonard Bernstein, was recorded live in Frankfurt, Germany, in September 1987, as part of the Mahler Chikulus series of re-recordings in the digital age. Karl Böhm's rendition of Mozart's "Requiem" is a classic masterpiece that has been known as the standard rendition of this piece since the LP era, and was recorded as a session at Vienna's Musikverein Saal in April 1971. It was done. This is the only analog source.

From the former Philips (currently Decca), one Mariinsky with Lee Gergiev as a soldier

Stravinsky's "The Rite of Spring" and Scriabin's "Poetry of Ecstasy" were prepared in collaboration with the Theater Orchestra. These two songs were recorded in a session in Baden-Baden, Germany in 1999, and attracted attention as excellent recordings using vacuum tube equipment.

And from Kawa EMI (now Warner), Beethoven's String Quartet No. 9 "Razumovsky No. 3" and No. 11 "Serfots" by the Alban Berg Quartet and Dvořák's Quartet introducing a great-value Fukushu album that includes No. 12

"America" on one disc. All three songs were recorded live at Vienna's Konzerthaus in 1989 sound. Beethoven's 2

The mountain is the second time for this group. Taken from the current collection recording.

Both master themes from the selection of the

Even the DSD mastering was meticulously done, using Esoteric's high-end equipment and M EXCEL cables. was used.

SACD producer Akira Nishiguchi describes this lineup as "a combination rich in variety." Regarding the two DG sound sources, he explained, "We focused on the suppleness of the Vienna Philharmonic and the resonance and depth of the hall." Ma

In "The Rite of Spring," by Gergiev, he says, "I wanted to pursue the reality of the instruments,

including the energy of the gran cassa, and make it a definitive album for audiophiles." Regarding the Alban Berg Quartet album, he says, "It was recorded with high resolution on-mic, so I wanted to convey the excitement and realism of the performance as is." All Denosques seem to offer Esoteric cooking methods that are a little different from the previously released CDs and SACDs.



Mahler: Symphony No. 5
leonard bernstein grasp
vienna philharmonic orchestra
(Deutsche Grammophon/Esoteric ESSG90266)



Stravinsky: Ballet "The Rite of Spring", Scriabin: "Ecstasy" "Prometheus - Poem of Fire"
Conducted by Valery Gergiev
Mariinsky Theater Orchestra
(Decca/Esoteric ESSD90267)



Beethoven: String Quartet No. 9 "A Zumovsky No. 3", No. 11 "Serio Dvorak: String Quartet No. 12 "America"
alban berg quartet
<Warner Esoteric ESSW90268)



Mozart: Requiem
Edith Mathis (S), Julia Hamari (A), Vi Eslaw Ofmann (T), Karl Ridderbusch (Bs), Karl Böhm's Vienna Philharmonic Orchestra, Vienna State Opera Choir, etc. (Deutsche Grammophon Esoteric ESSG90269)

Disc format: SACD CD hybrid
Case specifications: Beautiful paper digipak package
List price: ¥6,000 each (tax included)

All four works are completely limited production editions. We plan to carry a small selection on our website, focusing on audio sales nationwide.

•Contact:
Esoteric Co., Ltd. AV Customer Service Office
☎042(356)9235
•Stereo Sound Store:
<https://www.stereosound-store.jp/>

Tower Records has teamed up with Berlin Classics, a label that has a large number of historical recordings from the former East Germany, to reprint masterpieces on SACD CD hybrid editions, and the project is progressing smoothly. This season's latest works commemorate the 100th anniversary of the birth of German

master Otmar Suitner (1922-2010), and include three complete editions of operas on the Eterna label. Suitner played an active role in Shandong Germany and other countries. A well-known conductor who is a skilled craftsman. In addition to holding key posts at the Staatsoper and its orchestras in Berlin and Donsden, he is also known for his guest performances with the NHK Symphony Orchestra, and is deeply popular as an inheritor of the solid and dignified music-making tradition of Germany.

was proud of. There are many recordings, and this time three works are reissued: Mozart's "Escape from the Seraglio" (recorded in 1961), "Cosi fan tutte" (60s), and R. Strauss' "Salome" (866 o'clock). It was done. "The Seraglio" and "Salome" were recorded in Dresden, and "Cosi" was recorded in Berlin. Eterna Nuber's stereo recordings, recorded during the analog period in the former East Germany, are of high quality and are ideal material for SACD production. Once again, the original analog master tape is

Three operas conducted by Suitner converted from analog masters to SACD

It was sent to the studio of Christoph Stieckel, an engineer living in Ernest, and was carefully mastered.

Of the three, the one that attracts the most attention is "Salome." The world premiere was held at the Donsden Opera House in 1905, and ever since then, a special tradition has existed in the performance and performance of Richard Strauss's works. At the time of recording in 1963, Suitner was still in his 40s. The unique sound of Staatskapelle Dresden, which combines depth and power, is at full throttle, driving the drama with youthful propulsion and interpretations full of dramatic tension. Christel Goltz, who sings the title role, is a classic dramatic soprano who specializes in this work.

Ta. The other singers are also talented. The cherry on top is the brilliant acoustics of Dresden's famous recording location, St. Luke's Church. In addition to the silky technique and glossy pipes with rich reverberation, the percussion instruments have been restored to freshness through remastering. The sharp scattering of the old days is reminiscent of the sun. When the engineer who skillfully accomplished all of this is the master Klaus Struben, expectations are skyrocketing. The famous "Seven Vogel Dances" appear at the beginning of DISC 2. It's worth getting this 2-disc SACD/CD hybrid just to enjoy this. Of course, you can also listen to two works by Mozart.

Tae is enough. Thanks to careful reproduction, the singer's voice has a powerful softness and depth, and the lively expression draws you in. I also like the mellow warmth of the orchestral music, and I'd like you to fully enjoy the clear sound on the SA CD layer.



Christoph Stieckel, an engineer based in Vienna, has developed We are doing digitization and mastering.



Mozart: Complete opera "Escape from the Seraglio" Jutta Vrubius (S), Rosemary Rönisch (S), Rolf Aprek (T), Staatskapelle Dresden conducted by Otmar Suitner, Dresden State Opera Choir, etc. (Tower Records 0302842BC) 2-disc SACD 2ch CD



Mozart: Complete opera "Cosi fan tutte" Celestina Casavietra (S), Annelies Burmeister (A), Beter Schreier (T), Staatskape conducted by Otmar Suitner Les Berlin, Berlin State Opera Nowadays, etc. (Tower Records 0302843BC) 2-disc set SACD 2ch CD



R. Strauss: Complete opera "Salome" Christer Goltz (S), Ernst Gatestein (Br), Star conducted by Otmar Suitner Tukapelle Dresden, etc. (Tower Records 0302844BC) 2-disc SACD 2ch CD

*Both are limited to Tower Records, 2Kinjin edition

Steeple Chase SACD Hybrid Selection

Yuo Ohara

By Tower Records project

In commemoration of the label's 50th anniversary

SACD of popular works

There was certainly a time in the 1970s when European jazz was at its peak. In order to escape the rise of free jazz in the United

States and the trend of crossover (later fusion), as well as issues such as racial discrimination and compensation, many veteran

performers moved their base of activity to Europe.

It is. ECM and Enya were among these movements. Denmark's Independent Tonbel/ Staple Chase is one such event. This

time, the label's 30th anniversary project

As a result, a series of popular albums were made available as SACD CD hybrids in the form of Tower Records limited editions. DSD remastered at King Records Sekiguchidai Studio from 200Kb/24-

bit data generated from the original analog master in Japan. The CD layer is also uniquely created from the same DSD data. The person responsible for this work was engineer Hiroyuki Tsuji, and the supervisor was Hiromi Wada, as you may know. The four titles introduced here can be said to be masterpieces and popular albums that represent the same album, and include alternate takes that were added when they were released on CD in the 1980s.

I'm also glad that it happened. The lineup is 202. A total of 10 titles are scheduled to be released by the end of the second generation.

It would be no exaggeration to say that

"Duke Jordan Trio Flight to Denmark" is a record that symbolizes the label. The snow-covered jacket is reminiscent of the freezing cold weather, and the snow-covered jacket is impressive, but the performance is also filled with a bitterness and romanticism, which is likely due to the exotic nature of Scandinavia. With a clear outlook, familiar phrases are played out at a good tempo in "Blues of a Dangerous Relationship," and the simple yet smooth and fresh piano sound that spans from Ishiyama to the center is a DSD. Is it unique?

Kenny Drew has also recorded many songs for the same label, but when it comes to this one, it has to be "Dark Beauty", which features a black woman's boat ride on the all-black jacket. The content is hard bop, and with the best rhythm section of Pedersen-Heath, the performance is full of a driving feeling directly descended from Bud Powell. With a series of silver-like melodies and phrasing, it is so dynamic that it will make not only jazz fans but also those with a good taste in audio files groan.

It's a sound with a strong sense of humor. "Cafe Montmartre" can be called the stronghold of Stebel Chase. Many live performances have been released there, but the two albums by Stan Getz, performed as a quartet, have a wide variety of recorded numbers. Getz's melodic and emotional phrases

of humor. "Cafe Montmartre" can be

called the stronghold of Stebel Chase. Many live performances have been released there, but the two albums by Stan Getz, performed as a quartet, have a wide variety of recorded numbers. Getz's melodic and emotional phrases



Hiromi Wada (left), who supervises the series including mastering, and Mastering engineer Hirohito Tsuji (right)

The performance was truly full of poetic spirit, and the venue's soft

atmosphere was rich.

The studio recordings generally have an on-mic sound, but the live version also feels like the sound is captured closer to the performance, and I think this is the clear sound that is unique to this SACD reprint.



Flight to Denmark
duke jordan trio
(Tower Records SCSA1001)

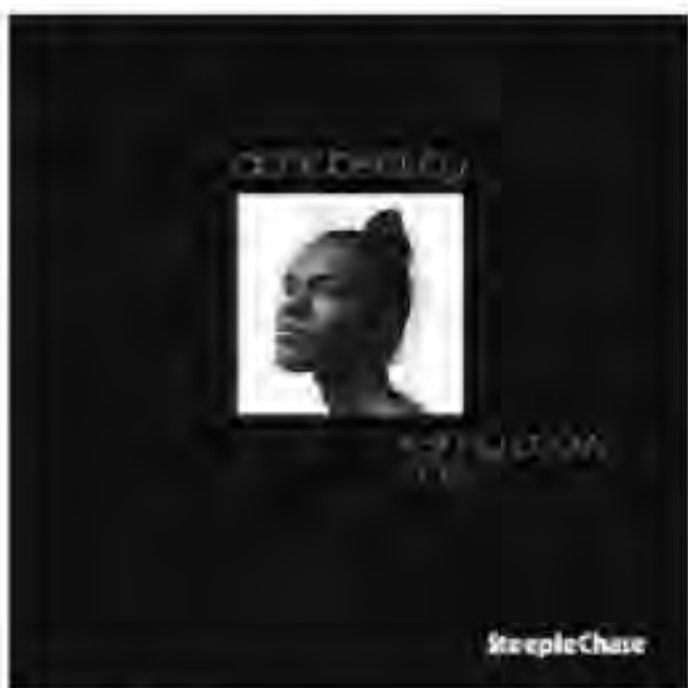

Dark Beauty
Kenny Drew Trio
(Tower Records SCSA1002)



Live at Montmartre Vol.1
(Tower Records SCSA1003)
Live at Montmartre Vol.2
(Tower Records SCSA1004)
stan getz quartet

Disc format: SACD 2ch//CD hybrid List price: ¥3,850 each (tax included)

*Both are exclusive to Tower Records. Completely limited edition

From Stereo Sound Company, "East Wind" label masterpiece analog disc released two works, "The Great Jazz Trio at the Village Vanguard" and "I'm Old Fashioned/Sadato Watanabe with the Great Jazz Trio." Both are made using original analog master tapes (14 inches), which are currently kept under strict protection at Universal Music. Based on this, he created a half-inch analog cutting master with twice the width of the magnetic tape and carved the grooves into the lacquer. High-quality analog in a completely analog domain, which is completely different from the current methods of digitizing and cutting.

First of all, let's applaud the appearance of the board. The Great Jazz Trio (GJT), led by piano virtuoso Hank Jones, is known as the first group of "The Great Jazz Trio at the Village Vanguard," with Ron Carter. This is a trio performance by Tony Williams. Live recording at Village Vanguard was February 10-20, 1977. The first time I heard this original version was when I was a student. The first verse of side A

Under the supervision of Shoji Sugawara, two of East Wind's masterpieces have been reprinted as analog LP records.

I remember being amazed by Tony Williams' amazing drum solo on "The Mooch," and listening intently to Ron Carter's skillful fingering during the second peak of BM. Hank Jones gives a calm performance from beginning to end, giving the impression that he is in charge of keeping all four songs on the record from going off the rails.

Sadato Watanabe was a mature 16-year-old when he recorded "I'm Old Fashioned." The recording at the first GJT mentioned above and at Vanguard Studios in New York is dated May 2, 1976. I remember listening to the original version when I was a student, and I felt nostalgic when I heard the reissue with stereo sound.

When I listened to the duo at home, I was surprised by the sense of unity in the performance, which made me think that these four members had been part of a band from the beginning. Recording engineer for both works His name is David Baker. According to the editor-in-chief of Stereo Sound magazine, cutting engineer Shinya Matsushita, under the supervision of Shoji Sugawara of Jazz Cafe Basie, worked to create a sound that clearly conveyed the passion contained in the original recording at the time. It is said that he worked very hard. I think the result was a great success. Two recommended albums that jazz-loving readers of this magazine should definitely listen to. It is.



The Great Jazz Trio at the Village Vanguard (stereo sound SSAR077)
Recorded: February 19th and 20th, 1977, Village Vanguard, New York (live)



Trio I'm Old Fashioned
Sadahiro Watanabe Who's the Great Jazz (stereo sound SSAR078)
Recorded: May 21, 1976 at Vanguard Studios, New York

¥8,800 each (tax included) *Limited edition
Specifications: Analog record 331/3 rpm, 140g regular edition
Sound Supervisor: Shoichi Sugawara
Cutting engineer: Shinya Matsushita (PICCOLO AUDIO WORKS)

*As this is an exclusive product for stereo sound, handling is only available on our website and Available only through mail order (available at some audio shops).
Contact: Stereo Sound Mail Order Dial 03(5716)3239
Stereo Sound Store: <https://www.stereosound-store.jp/>



Best Sound category
"Classical, Jazz, Fusion"

[Best award]

From the work "PIAZZOLLA"
"Shark" Dai Myata
Publisher: Nippon Columbia
Format: PCM96kHz/24 bit 2ch

Mixing Engineer Toshiyasu Shiozawa (Nippon Columbia Co., Ltd.)
Mastering Engineer Hiroshi Sato ((Nippon Columbia Co., Ltd.))

Work "MARLENE'S SONG BOOK-MEMORIES for TOMORROW-"
From (UICZ9218)

"(THEY LONG TO BE) CLOSE TO YOU" Marlene
Publisher: Universal Music LLC
Format: CD
Mixing & Mastering Engineer Masakazu Hemura (In-and-Out Co., Ltd.)



Best Sound category
"Pops, popular songs"

[Best award]

Work Distribution single "Baby I love you so" Shota
Shimizu Publisher: Sony Music Labels Inc.
Format: PCM44.1kHz/16bit 2ch

mastering engineer Hidekazu Sakai (Sony Music Solutions Inc.) Minoru
Mixing Engineer Kaneko (GIALLO PORTA)

Work [SOFTLY.] (WPCL13361)

"LOVE'S ON FIRE" Tatsuro Yamashita
Publisher: Warner Music Japan Co.,
Ltd. Format: CD

Mixing Engineer, Mastering (Smile Music Publishing Co., Ltd.)
Engineer Shigeaki Hashimoto (Mixer's Lab Co., Ltd., Warner Music Mastering Co., Ltd.) Yoshika Hayashi
Assistant Engineer Isao Kikuchi Co., Ltd. (Planet Kingdom Co., Ltd.)

-Under 35 years old division-

Work Distribution single "ARROW" the chef cooks me
Publisher: only in
dreams Format: PCM96kHz/24bit 2ch

Mixing Engineer Ryoma Nakamura (Freelance)

From the work "One Day"
EP "One Day" ZILLION
Publisher: Sony Music Labels, Inc.
Format: PCM48kHz. 24-bit 2ch

Mixing Engineer Shizuo Harada (Sony Music Solutions)



Super Master Sound category

[Best award]

Work [THE REST OF YOUR LIFE]
"Save the Last Dance for Me (Cover)" Mie Joie
Publisher: mdk music
japan Format: PCM192kHz. 24 bit 2ch

Mixing & Mastering Engineer Kazuki Nagae (Nagoya University of Arts)
assistant engineer Minami Takahashi (Yu Digicom)

From the work "Another Answer"

"Sing Sing Sing" Kanae Izutsu
Publisher: JellyfishLB
Format: DSD11.2MHz 2ch

Mixing Engineer Mastering (Mixers Lab Co., Ltd.) Hiroyuki
Engineer Hideto Takada Tsuji (King Sekiguchiai Studio Co., Ltd.)



analog disc section

[Best award]

Work | From Billie (AMCE004)
[You've changed]MAYA
Publisher: Disc Union Co.,
Ltd. Format: 30cm 33-1/3 turn disc

Cutting Engineer Mixing Tezuka (Nakayo Kasei)
Engineer Kazumi Matsushita (PICCOLO AUDIO WORKS) Toyo
Cutting Studio Shinya Kasei Co., Ltd.

[28th Japan Professional Music Recording Award]
Award-winning works decided

the Japan Audio Association, and the Japan Music Studio,
by a total of five organizations including the Geo Association,
section of the 28th Japan Professional Music Recording Awards is sponsored
The winning works have been decided. Each

Category", and "Broadcast Category",
Category", "Immersive Category", "Analog
The awards are divided into "Best Sound
Digital (2 categories)", "Super Master Sound

"Best Sound Category", and "Sue (Editorial
Category", "Per Master Sound Category", "Analog",
Introducing the award results of "Good Disk
do. Department)

SS Information

Air "QX5 Twenty" upgrade service launched

Axis has started an upgrade service (Ne 12) for Air's digital hub "QX5 Twenty". This upgrade allows the allowable rate for network playback (Ethernet input) to support DSD1/2M and PC M384k 32-bit music sources. The cost is 200,000 yen, including tax and labor (excluding shipping). In addition, "Q X5 Twenty" will be sold in Ne 12 specification from now on.



Air QX5 Twenty (Net2 Version) ¥1,900,000

•Inquiries: Axis)03 (5410)0071

CS port, E crossover, New release of "ACN400"

From the CS port, The tronic crossover "ACN400" has been released. This unit is an analog type that can accommodate four types of configurations as standard: 2-way, 3-way, 4-way, and 3-way, 3-way, and 3-way. By adopting a newly developed MK filter, there is no phase change even with a slope characteristic of 12dB, making it possible to precisely separate overlapping notes one by one.



CS port ACN400 ¥1,800,000

•Inquiries: CS Port Co., Ltd. ☎076 (461)4188

Wireless playback compatible speakers are now available from Sonus Faber

From Sonus Faber Introducing Omnia, a speaker with a built-in amplifier that supports Bluetooth and streaming playback. It has a 4-way 7-speaker configuration and uses proprietary DSP technology to radiate spacious sound throughout the room. Inputs include HDMI (ARC), LAN cable, and mini DIN (RCA pin conversion cable included) terminal. Equipped with etc.



Sonus Faber Omnia ¥345,000

•Contact: Noah ☎03 (6902) 0941

ZYX, Ultimate series phono cartridge becomes EX version

ZYX Ultimate Series Stereo MC The cartridge has undergone a model change and has been reborn as the Ultimate E series. The key point is the adoption of a one-point ground structure in which the left and right ground output points on the armature are the same. This causes the left and right signals to have the same magnetic field ring. It is said that it is now possible to generate electricity at the edge of a building, making it possible to reproduce clearer sound.



ZYX Ultimate-EX-Astro ¥1,280,000 Also Ultimate-EX-Diamond, Ultimate-EX-Dynamic, Ultimate-EX-Omega etc. available

•Inquiries: Yuka no Enterprise ☎06 (6170)5731

Accuphase, large capacity clean power supply Latest model "PS1250" released

Accuphase is a large capacity clean power supply PS. The 1200 was introduced in 1997. The 6th generation "PS1250" has been released. A feature of this device is that it is equipped with a "liquid crystal display (LCD)" that allows you to observe input and output waveforms, etc. It also has a wealth of features, including a circuit that can generate highly accurate reference signals without using an oscillator circuit, and 10 highly reliable AC output terminals.



Accuphase PS1250 ¥800,000

•Inquiries: Accuphase Stock 045 (901)2771

France's Focal's top-of-the-line headphones now available as the second generation SG version

Utopia (released in 2016), France's Focal's top-of-the-line headphones, has been reborn as the second generation Utopia SG. The M-shaped dome-shaped full-range open-back driver uses pure beryllium, which is unique to the company, and the voice coil has been changed to aluminum alloy and high-purity copper. In addition, by improving the brushes of each part, we have achieved better sound quality and durability than ever before.



Focal Utopia SG ¥600,000

•Inquiries: Luxman Co., Ltd. 045 (470)6991

New series "Fluette 500" added to Audio-Technica's cable lineup

The "Fluette 500" series has been added to Audio-Technica's mid-range cable line "Fluette." It applies the "Heat Relieve" processing cultivated in the high-end "Fluette 700" and adopts the hybrid conductor "PCUHD + Hyper OFC." The current lineup includes two types of analog line cables (A total of 3 types: "AT-IC500X" for balanced transmission, "AT-IC500R" and "AT-AC500" power cable.



are available Balanced analog line cable Audio Technica Fluat AT-IC500X ¥25,000 (pair) Price is 0.7m in length, various features and

•Inquiries: Audio Technica Co., Ltd. Customer Service Desk! 0120-773-417

Zonotone's first LAN cable is born

Zonotone has released its first LAN cable, "Supreme LAN1". The conductor is a hybrid of four carefully selected types (ultra-high purity 7N class copper, high-purity oxygen-free copper wire PCUH D, pure silver coated OFC, and high-purity oxygen-free copper OFC) using the company's method. A thick aluminum wrap shield is used for the part RJ45. The terminals are made by Panduit in the United States, and the Ethernet standard is CAT/5e compliant.



Zonotone Shupreme LAN1 ¥59,000 Price is 0.6m in length, 1.2m (¥68,000), 2m (¥80,000) also available

•Contact ☎(6914)6255Maezono Sound Lab✉03

New colors added to Sound Magic's audio rack "HSO3"

Sound Magic, which only had shelves with a black finish Two new finishes, "Dark Cherry" and "Light Cherry," have been added to the 3-tier audio rack "HSO3." The 3mm-diameter low-carbon steel column is available in two finishes, silver and black, depending on your preference, so it will be available in a total of six variations in the future. It becomes. The shelves are made of 10mm thick high-density, high-compression MDF, and are 556mm wide and 556mm deep. The diameter is 360mm.



Sound Magic HSO3LB (shelf, light cherry, support, black) Open (estimated price around ¥37,000)

•Inquiries: Network Japan Co., Ltd. 06(6105)0707

The Japan Audio Society publishes a commemorative issue of the JAS Journal to commemorate its 70th anniversary.

The Japan Audio Association, a general incorporated association, celebrated its 70th anniversary on October 4, 2022. To commemorate this occasion, a commemorative issue has been published in the association's journal, "JAS Journal." We would like to introduce it to you.

The Journal JAS Journal is a popular information magazine where you can learn about technical information used in the latest audio products and industry trends, mainly through contributions by engineers from member companies and individual members, but it is not only for members but also for the general public. The magazine is available to readers free of charge and can be viewed on a variety of devices, including computers and smartphones. This commemorative issue is dedicated to audio and with the theme of looking back on the past 10 years and looking back at the main things that have happened in the audiovisual industry, we will cover three topics: 10 years of high-resolution development, 10 years of analog restoration, and 10 years of breakthroughs in stereophonic sound. An in-depth article has been published about it. At the same time, we will not only look back on the past, but also hold a commemorative discussion on the theme of "What is required of future audio?" Patterns are also included. You can read it for free by opening the URL provided separately, so I recommend that you give it a read.



URL: https://www.jas-audio.or.jp/journal_contents/journal202210_post117518



QR code for the 70th anniversary issue of the Japan Audio Association

Series 6 musical abduction

Huh Mitsujun

Simon Rattle and the London Symphony Orchestra came to Japan and performed various programs at various locations. For the first

time in a while, I was able to fully enjoy the work of a first-class orchestra. At the same time, I started to notice things that didn't bother

me so much before. In order, I went out to the venues were User Kawasaki, Suntory Hall, and Tokyo Metropolitan Theatre. All of these are fine venues built specifically for concerts. If we include facilities in Opera City, Ueno, and Minato Mirai, we can say with certainty that there is no other metropolitan area in the world that has so many large halls of a certain standard. Recently, a splendid hall has been completed in Odawara, although it is questionable how much it will be used. If you take the Shinkansen, it is 30 minutes from Tokyo Station. The castle moat and trees can be seen from the lobby, which is a pleasant feeling. No one had the idea to build something like this near the Imperial Palace. I think so.

Now, as I listened to the London Symphony Orchestra almost every day, I was keenly aware of the fact that the impression of a performance changes quite a bit depending on the hall. I don't know what to do now, but because of the coronavirus pandemic, I've been spending more time listening to music at home than before. Then, your ears become accustomed to the home stereo. Unexpected

It's a discussion, and it feels really good.

It's getting worse. Then go to the venue

When I looked at it, I realized that I should be able to hear the bus a little more, and that it would be better if I couldn't hear it at all.

For example, if you want to hear and see all the interactions between the woodwind instruments, it's best to look down from the side of the stage. Don't you want to hear the long flute solo in Bruckner's Symphony No. 7 as close to the sound as possible?

However, if you sit behind the first violin, the bus will be farther away. If you go to the front of the first floor, the balance of the strings will be good, but the sound of the woodwind instruments may not come directly to you. One seat depending on the characteristics of the hall, the program, and the price. I'm going to buy 100 items. That is unlikely.

However, if you listen to it in a number of halls, each with its own sound settings, you will be able to understand, if not exactly what the hall was trying to do, but what the result was. I understand that very well. For example, when I listened to "La Valse" at Suntory Hall and Tokyo Metropolitan Theatre, I found that the former is trying to make you listen to music.

However, it was hard to shake the impression that the latter was trying to make the sound sound tangible. To put it simply, the Tokyo

Metropolitan Theater is where you can hear a lot of subtle sounds. In fact, many of my acquaintances who visited the venue that night were happy to hear so much sound. It is a spectacle in its own right. Of course, it goes without saying that the ability of the orchestra and conductor is also a factor. If I had only heard this sound, I would have been satisfied.

However, at Suntory Hall, "La... When listening to "Valse," sensual expressions and undulations are often expressed. At the same time, I was surprisingly dissatisfied with the fact that I couldn't hear such detailed sounds in this hall, but if I were to ask which one better expresses music, I would say Suntory Hall. I have no choice but to answer. While listening to the sounds of Suntory, I realized that this hall was being built. Karajan must have been in an advisory position when the project was created, but I don't know how much he actually gave his opinion, but perhaps a hall is a place to listen to music, not a place to listen to music. I also thought that he might have taught me that. Of course, if so, that ideal

As an example, Musikvereinsaal probably came to mind. In fact, if you compare the sounds in this way, the sound of Suntory Hall is closer to that hall in Vienna than any other hall in the Tokyo area. They are more similar in direction than in actual sound. And it is in Tokyo that the musicians listening to the sounds on stage are praising. is Suntory Hall.

However, the story is not easy. There is no reason why we should just build copies of Raba Suntory Hall all over Japan. I felt that Suntory Hall better conveyed the atmosphere and expression of the music, but I also couldn't forget the acoustics, which were cold but had good resolution. That's that. But I can't shake the feeling that it was really interesting. And I am once again keenly aware that Suntory's acoustic image, despite its modern appearance, is oriented towards the past. That should be fine, but I have a suspicion that it is not the modern sound of this

moment. Rattle and Salonen, I like this. Conductors who like to listen to music are generally better suited to halls where the sound comes out quickly and resonates quickly, or halls that are not overly resonant. The Barbican Center, home of the London Symphony Orchestra, is a venue that doesn't have a good reputation with both audiences and performers, but there are good seats available.

It's not that there aren't any. However, that is pins

It's like a pot, and it's very limited.

There are only a few. The London Symphony Orchestra I listen to there is well-balanced, not too loud, and the visibility is very good, so unless you want to listen to Bruckner, which sounds like a church organ, it's very comfortable.

When I listen to Rattle's Mahler, I am amazed at how Rattle composes Mahler with a subtle sonic sensibility, much like contemporary music. I have never heard a sound like this in Japan. By the way, the Musikvereinsal is an extremely unique venue, with an old-fashioned tone that would leave even the London Symphony Orchestra stunned. It's true that the sound is definitely sounding that way, but I still think it's strange.

If there was only one hall in the town where I lived, I wouldn't have thought of something so complicated. If you live in Vienna, the regular concerts of the Vienna Philharmonic are bound to be held at the Musikvereinsal. There is almost no choice. However, in Tokyo, I can't help but think that it would have been better if this concert had been held at Suntory, or that I could have heard more detailed sounds if it had been in Ikebukuro.

I also went to an evening where

Khun Oo Paik (I can only say that this literal pronunciation of the alphabet is very poor) played granados at the Prince's Hall. The second half of the program is "Gojescas," and it is quite exceptional that this piece is played for an hour.

Alicia de Larrocha used to be good at it. It's a romantic piece, and it's a great song, but there aren't many opportunities to listen to it live. In Tokyo, they played Ravel's "The Grave of Couvelin" in the first half, but I heard that in Osaka, they only played Granados. It was quite a drastic move, and since it was a small Oji Hall, the audience seats were full, but that wasn't the case. If so, the organizers should play some German music. He must have begged her to do

so. To be honest, Oji Hall is a venue located inside a building, and the space is so small that the full-blown sound of a modern grand piano would make it feel too small. That's how modern the piano is, and how many modern masters are there. It is making a loud sound. In such a space, the center of gravity of the music appears to be lower because the middle and low frequencies are so loud. Pike's left hand already has terrifying power, and at times it feels like a giant rock rolling over. Then, Spain's

The composer's works do not sound Southern

European in the popular sense. On the contrary, it intensifies the atmosphere of self-questioning and euphoria, much like Liszt's "Sonata in B minor". All in all, it was a great performance and an interesting evening.

Pike's "Goyescas" is just C I just got D. Korean DG It seems to have been manufactured. It would be a problem if these items sold out. As expected, the collection of Brahms pieces that Paik played has been on sale for only a short period of time, and is fetching exorbitant prices on the second-hand market. Listen on streaming services So, it's not really a problem, but I don't feel secure unless I have something, probably because I belong to the older generation. Apparently there are such people out there, and Paik's Chopin Nocturnes, which was previously only available online, was recently released on record and later on CD. a

I noticed that "Goyescas" is Around the same time the CD was released, I already listened to it on Amazon. I was now able to do it. This CD has a slightly different atmosphere than the raw one. It's more naturally Latin-like. I heard from people involved that Bike was particular about the tone, and at Granados he wanted brightness by moving the piano's music stand. At close range,

I may have noticed the attempt, but I didn't notice it from my seat. Although the coronavirus pandemic has not subsided, pianists who do not require a co-star to come to Japan seem to have made a comeback. In January, Pogorelich will be coming for the first time in a long time, but a recital at Asahihama Rikyu Hall is scheduled.

has been established. That person also made an outrageous sound. put out. I love Suntory Hall, and have often given recitals there in Tokyo, but I wonder how those strongest and weakest sounds would resonate in other venues. That's why I bought the ticket on the day it went on sale. But, if I may say so myself, I'm sure this is what I think. In some ways it was good, but in others it was unsatisfactory. He says he doesn't want to be satisfied.

This seems to be a characteristic of humans. When we hear a clear sound, we want it to have an air of elegance, and when we hear an old-fashioned sound, we want a modern precision. Is something in between the two extremes what we really want? No, Even if there is something in between, I'm sure There will be another dissatisfaction. Truly it is cause and effect. However, because of the cause and effect Human civilization and culture have flourished no doubt. Morality is often "enough" Teach them to know. For peace of mind This is a valid teaching. But one person is short if I knew that, this world would be so much better It must have remained that simple.

eternal dissatisfaction

Usugi U · Bros330AH

Notice of start of orders for "Special specification model Limited Edition"



Japanese cedar
U-Bros330AH Limited Edition (Photo shows WE300B specification)

Usugiri Bro

The 330AH is the winning product of this year's Stereo Sound Grand Prix, and is the model that will be displayed in commemoration of the 130th anniversary of the Usugi Research Institute (last year). That's why this machine has many features such as:
It has content. First, the city's popularity has increased further with the start of reproduction production by Western Electric (WC), the American manufacturer of wooden houses.
A thermal triode 300B must be used in the output stage. Book The machine is this 300B new In order to bring out its charm,
① AC ignition of filament of electrical performance and quality)
Class 2AB operation (exciting the grid to the positive region to increase output and reduce idling current to extend vacuum tube life) is adopted, and the output stage circuit uses a circuitron circuit that opens up the possibility of push-pull mountain power. This is The company's latest power amplifier

This is a circuit whose superiority has been confirmed in the previous series, and this is the fourth time it has been adopted in this machine.

As mentioned above, the U-Bros330A is a noteworthy model with a monoblock configuration that was developed by fully utilizing the core technology of recent Usugi vacuum tube power amplifiers. Mountain power is 30W.

We would like to inform you that this U · Bros330AU will be distributed as a special specification model "U · Bros330AH Limited Edition" (limited production product) of this magazine's sister magazine "Tube Kamikuni", and orders for it have started. Or.

This special edition model has a different external finish from the general commercially available U · Bros330AH, with the main body chassis painted in pearl white.

The transformer case has been changed to a black leather-like paint finish (see photo). This finish is inspired by a piano keyboard, and the contrast between white and black is in line with the Usugi brand's original design.
دارى رو

The special edition model BIOS330AH this time comes in three types: WE-made 300B output tube included, PSVANE-made 300B output tube included, front ax only included, and 300B output tube not included.

Please note that orders for this special edition model "U · Bro \$330AH Limited Edition" will be placed on our mail order site "Stereo Sound STORE" (details are posted separately), and the completed products (pair) will be shipped directly from the Usugi Research Institute. (Scheduled to be shipped sequentially from late March 2023). The order deadline is Thursday, January 5, 2023. (Editorial department)

Distribution contents

- ① WE300B (2021 reprint Sakagyuiki pipe) Yamajin pipe accessory specification (completed product)
U-Bros330AHW-WE ¥2,310,000
- ② PSVANE 300B output tube included (completed product)
U-Bros330AHW-PS ¥2,035,000 ③
- Only step pipe included, no output tube 300B Mr. Jin (completed product) U-Bros330AHW- L ¥1,815,000

*All prices include consumption tax and shipping, and are bare

*Vacuum tube protection cover G330W (Y44,000, tax included, bare leather-like black paint) is available as an option sold separately.

It has been. If you wish, please select it from "Options" when ordering on our mail order site (URL below).

Stereo Sound mail order site
[Stereo Sound STORE]

<https://www.stereosound-store.jp/>

•Contact information when ordering

Stereo sound mail order exclusive dial
☎ 03(5716)3239

•Inquiries regarding product specifications:

Usugi Research Institute 044(712)4632

•Order application deadline

Thursday, January 5, 2023

U-Bros330AH Limited Edition

Main Specifications

- Output: 30W (40 80 160)
- Input sensitivity: 1.0V (1kHz, 30W)
- Vacuum tube used: ECC83/12AX7A (GE) x 1, 6CG7 (Electro Harmonix) x 1, ECC81/12AT7 (Philips ECG) x 2, 300B (Western Electric) x 2
(*The brand of output tube varies depending on the specifications)
- Dimensions/Weight: W364 x H201 x D218mm. 17.5kg

A line

Arc Joyer-51

art crew-309

Ilex54

accuphase-41

AXISSMarilyn 1

Asahi Stereo Center304

Acker-47

Atelier Je-tee-312

Avac-356

andante largo245

Ikeda Sound Lab Zoo-243

Osugi Research Institute156

AET-241

A & A Design-426

esoteric-12

M plus concept235

electric18, Table 3

Elex-250

audio sound252

audio-Technica-167

audio notes64

audio malo357

audio union-246

audioland302

audio replus-62

Ortofon Japan-240

Onken-301

ka line

gas light307

Kamani-355

Central Electronics150

Cabin Osakaya257

Kyodo Electronics Engineering-40

King International-311

Kusakabe297

GRACE

GRACE248

Cross Audio-298

KEF JAPAN-26

Sa line

Sound Create-259

Sound Support (Lite Denkiland) 303

Sound Space255

sound pit-254

CSR-58

CS Field-244

CS port239

G-clef acoustics160

Simam Sen-359

zoot communication-250

Stella310

Sumiya Sound Gallery-425

Zephan-3

Sendai Nodaya-251

ta line

dynamic audio-260

time lord156

Taiyo International29.65

Taktstock-158

Tanzawa Denki Co.-427

D&M Holdings 34, 264, Table 4

DYNAUDIO JAPAN

DYNAUDIO JAPAN163

Technical Audio Devices Laboratories-164

Digital stream-165

Tereon-256

Triode-33

Na line

Nasbeck166

Japan Onkyo Engineering-60

Network Japan353

Noah-35

Nodaya (Sendai, Koriyama, Fukushima, Miyakode) 299

is line

Harman InternationalTable 2

High sound310

Lin Japan154

panasonic153

Hamada-258

PDN168

Fundamental-236

Fidelix360

Fehren Coordinator162

bright tone22

Pro Shop A&P300

Berenplatte-262

Whole Tone City Yokohama-425

Ma line

Micro Farad-306

My Sonic Lab237

Maezono Sound Lab-242

Masteratsu Audio Project 311

max audio-253

Ya line

uaudio.com358

Yukim-32.238

Ra line

Luxman48

Ligere-66

rewire354

Stereo Sound

STORE



Stereo sound original music software catalog



Congratulations!!! 40th anniversary limited record
 Present with the latest cutting
 A long-awaited 45 rpm disc for analog fans.

safety ground -40th ANNIVERSARY BEST-

2-disc analog record set
 45 rpm 180g heavy board
 SSAR-071~072
 ¥11,000 (tax included)



To commemorate the 40th anniversary of AnzenZen's debut, 12 songs with stereo sound have been released on a long-awaited 45 rpm record. Aiming for the best possible sound, we went back to the well-preserved original master tapes from the 1980s and remastered and cut them.

Anzenchichi vocalist, Koji Tamaki. The richness of her voice and the breadth of her range that go beyond that of an ordinary person, as well as the expressiveness of her worldview in her lyrics, make her a unique and unique figure. From his unique whisper-like nuances to his heart-rending loud expressions, he has a voice from another dimension that is hard to believe could come from just one person. Koji Tamaki sings "An

We will bring you the best album commemorating the 40th anniversary of "Zenzen."



Disc1	
[Side A]	[Side B]
① Wine red heart	① Harmony at the end of summer
② Premonition of love ③ To you	② Blue Brain Eris
	③ Friend
Disc2	
[Side A]	[Side B]
① To me the	① Two people wet with sex
② continuation of the dream	② Juliet
③ Goodbye to sadness	③ Smile

Produced from 1980s analog masters
 safety zone vest



analog record
 33 rpm 180g heavy board
 SSAR-040 ¥8,800 (tax included)

[Side A]	[Side B]
① To me	① Feeling of love
② The Heart of the Wine Robber	② To you
③ Friend	③ Goodbye to sadness,
④ The end of summer... (Inoue Yasui Safety Zone)	④ Eris with dark eyes
Continuation of the dream	⑤ Mecedry

Safety Zone Vest Part 2



analog record
 33 rpm 180g heavy board
 SSAR-044 ¥8,800 (tax included)

[Side A]	[Side B]
① Juliet	① I like it
② Two people wet by the moon	② I'm impatient
③ I see you in the morning sunlight	③ Masquerade
④ To those days	④ Let's start with Love You
⑤ Close your eyes	⑤ Orange

New

analog record collection

LP record



Koji Tamaki LIVE

Asahikawa City Public Hall

“Hometown Orchestra Concert Tour 2015” Impressive Chiakigaku
 echoed in the place of birth

“Singing voice of the soul” is revived on analog version!!!



Analog record 2-disc set
 330rpm 180g heavyweight
 SSAR-073-074 ¥11,000
 (tax included)



“Hometown Orchestra Concert Tour 2015 Koji Tamaki LIVE Asahikawa City Public Hall, an analog record using the original master of the final performance has been completed.

This is a set of two 33rpm 180g heavyweight records produced by Stereo Sound to celebrate the 35th anniversary of Koji Tamaki's debut.

A moving Chishugaku performance that resonated in Asahikawa, Koji Tamaki's birthplace. Listen to Koji Tamaki's warm voice of love along with the vivid sound that only analog records can provide.

recorded music	
<p>Disc1</p> <p>[Side A] ① Longing Flowers bloom well ③ On top of the chimney of Kanonto factory @All I Do</p>	<p>[Side B] ② If we are together ④ Searchlight 4) What else is there Daibo</p>
Disc2	
<p>[Side A] ①① Happy Ranno In that era... ② Because there is no one on the right ③ Sun-san</p>	<p>[Side B] ① MIMI LONELY ② 出逢 ③ Melody</p>

The joy of listening to Koji Tamaki's loving singing voice on analog record

Koji Tamaki



analog record
 33 rpm 180g heavy board
 SSAR-045 ¥8,800 (tax included)

[Side A]
 ① Longing (Instrumental)
 Kuroman ②
 Don't go ④ Neil
 ⑤ A human-like moment

[Side B]
 ① Lamp of happiness
 Zaik ,
 ③ Because you are not here
 ④ melody
 ⑤ melody

Koji Tamaki LIVE Kawa City Public Hall
 Late Higashiguchi CONCERT TOUR 2015

Star of the Gunzo Koji Tamaki



analog record
 334 rpm 180g heavy board
 SSAR-047
 ¥8,800 (tax included)

[Side A]
 ① Everyone is in a dream (Hamaguchi Kunosuke, Inzo, author passed away at the age of 73) ② Love song..... (Koshy Fubuki passed away at the age of 56)
 ③ I open the night in a dream of "life" (Journey passed away at the age of 62) ④ I really love you... (Kajin Yashikita, 64 years old)
 ⑤ LOVE YOU..... (Ozaki passed away at age 20)

[Side B]
 January light (Masatoshi Kuroki passed away at age 81)
 ②初恋..... (Toru Murashita, 46 years old)
 ③ That true
 live once again..... (Kazuhiko Kato, Takeyama, 62 years old) (99yoshi)
 ④ It's hard being a man Atsumi, 68 years old)

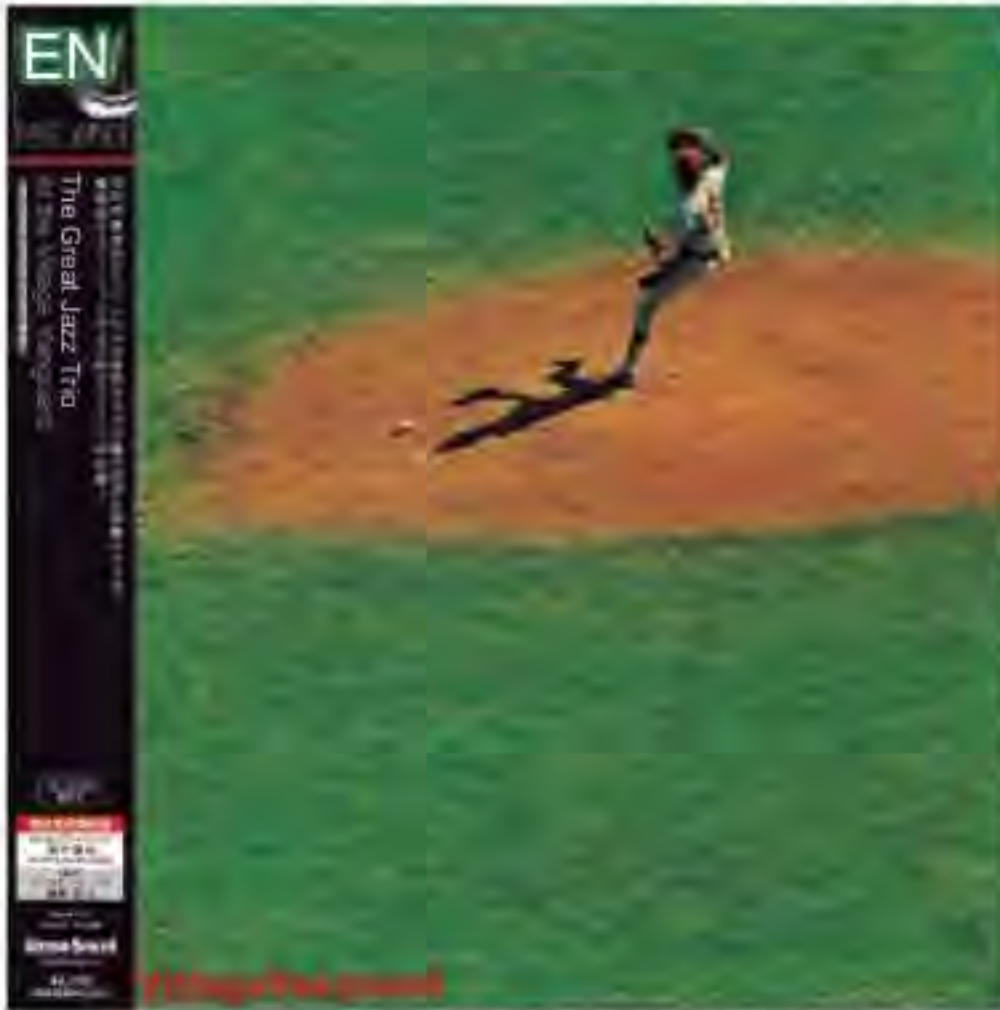

At the Village Vanguard

the great jazz trio



Analog record 33x rotation regular version
SSAR-077 ¥8,800 (tax included)

Performers: The Gray Jazz Trio = Hank Jones (p),
Con Carter (b), Tsunori Iwanaga (ds)
Recording: February 19, 2019, Village Vanguard (live)

*Recorded songs [Side A]		[Side B]
① Moose Chi Mooch		(1) Fe Ivaz
② 夢の島 Ma		212+12



I'm Old Fashioned

Sadao Watanabe with the Great Jazz Trio



Analog record 33! Rotation regular version
SSAR-078 ¥3,800 (tax included)

Performers: Sadao Watanabe (as), The Great Jazz Trio = Hank Jones (p), Ron Carter (b), Tor Williams (ds)
録音: May 21, 1973 New York, Vangad Studio

*Recorded songs [Side A]		[Side B]
(1) Ninno Amation		① I concentrate on you
(2) Guin		② Chelsea Bridge
33:10 blues		3 I'm Old Fashioned
④ 夢の島 Nisodo		④ One for Sea... Juhyo" Theme

Two popular works from the "East Wind" label
Supervised by Shoji Sugawara, owner of jazz cafe "Bacie"
Reprinted on analog record

East Wind is a famous producer. This is a jazz specialty label founded in Japan in 1974 by Kiyoshi Ito, Yasohachi Ito, and others who were active as singers. After its launch, the label rapidly became a popular label, releasing works by popular Japanese and international jazz musicians such as Masaaki Kikuchi, Masahiko Togashi, Terumasa Hino, Ann Burton, Cedar Wilton, and Art Farmer. In addition to the high quality of the performances and artwork, it also attracted a lot of attention from audio enthusiasts due to its excellent recording quality, and even today, about half a century after its introduction, it is still used at audio events and jazz. There are many opportunities for East Wind label works to be played in cafes and other places.

This time, we will be reproducing "At the Village Vanguard/ The At the Village Vanguard", which is particularly popular among audio enthusiasts among East Wind's works.

"Great Jazz Trio" (recorded in 1977) and "I'm Old Fashion Sadao Watanabe with the Great These are two works by "Jazz Trio" (recorded in 1976).

Both are with the full cooperation of Universal Music.

Uses original analog master tapes We have realized the production of LP records using an all-analog process. The person who supervised the sound quality was Mr. Shoji Sugawara, the owner of the jazz cafe "Bacie", who was close friends with Mr. Yasohachi Ito when he was still alive and consulted on sound quality since the original release. Mr. Shinya Matsushita, a young engineer who runs PICCOLO AUDIO WORKS in Yushima, Tokyo, squarely faced his commitment to strict sound and carved the sound onto the lacquer disc. The two of them teamed up and used a combination of Scurry cutting lace and Westrex cutter head (same as Rudy Van Gelder's), which was thoroughly restored by Mr. Matsushita. The sound of "Jazz!" was etched onto the lacquer record. Be sure to enjoy the charm of the jazz sound, which has been updated with careful production methods unique to modern times, while also making full use of vintage equipment. Please enjoy with us.



SACD/CD hybrid
Single layer SACD+CD
Single layer SACD



Swing! Sinatra Basie Quincy (1964 work)

frank sinatra



- ① fly me to the moon
- ② leftover love
- ③ Believe in yourself (from "How to get promoted without trying")
- ④ More (from "World Cruelty Story")
- ⑤ I can't help but love you
- ⑥ Hello Dono!
- ⑦ I Hna Be An One
- ⑧ The fun begins now
- ⑨ The Good
- ⑩ Life 10 Soives and Lovers

SACD/CD/Hybrid

SSVS-018

¥4,950 (tax included)



Sinatra's Sinatra(1963 work)

frank sinatra



- ① You are firmly mine
- ② Morning moments
- ③ Second Time Around
- ④ Nancy
- ⑤ Witch craft
- ⑥ Young at Her, All the Way How
- ⑦ Little We Know
- ⑧ Puckett's Happiness
- ⑩ Oh What It Seems to Be
- ⑪ Call Me Irresponsible (Haha is the King)
- ⑫ Absorb you dreams

SACD/CD hybrid

SSVS-017

¥4,950 (tax included)



My Way (50th Anniversary Edition) (1969 work, 2019 work)

frank sinatra



- ① Futch Hohut Huffins
- ② Pandon't We
- ③ Hallelujah, I Love Her So
- ④/Estady
- ⑤OI My Tomorrows
- ⑥My Way
- ⑦A Day in the Rhino of a Nord
- ⑧For Once in My Life
- ⑨If You Go Auno 10
- Mrs. Robinson
- ⑩my way duel with willie nelson
- ⑪my way duct with luciano pavarotti
- ⑬ My Way
- Live at the Inson Theater, June 13, 1971]
- ⑭: My Way
- [Live at Go Reunion Arena, October 24, 1987]

SACD/CD hybrid

SSVS-019

¥4,950 (tax included)



Sinatra Live at the Sands (1966)

Frank Sinatra with Count Basie Orchestra



- ① Come Fly One's Me
- I've Got A Crash 14
- On You
- ② i've cut You Under My Skin
- (4) Isoshigi
- (5) Streets of Paris Mus
- ⑥ Shin No Oh My Baby
- Fly Me Hey the Moon
- ⑧ One Flock Jump
- (Monolog)
- ⑩ You Make Me Noir Zo Young
- ⑪ all of me
- ⑫ my life
- ⑬ Quincy Jeans (arrangement, conductor)
- Green Moss: January 26-29, 1966, May 1, 1966 Las Vegas, Sands Hotel (live)
- I wish to drink to pass the time
- That negative thing
- that was fun, Don't Worry
- Pout Me
- Someday, somewhere
- 18 Angel A Is
- my town chicago
- (End Monologue)
- Hiwagamachi Shikai (Finale)

SACD+CD (2-disc set) SSVS-011~012

¥5,500 (tax included)



Barbara Chante Barbara A Chanson for Myself (1964 work)



- ① Longing for coldness
- ② Ale
- ③ Le Belle Age
- ④ In the forest of Saint-Aman
- ⑤ I don't know the language at
- ⑥ Noyon Station
- It's raining in Annan
- ⑦ Hats
- ⑧ off Han 8 yuan 15th
- ⑩ handbags
- ⑪ The much when you return
- Crying I'm neither polite nor kind, but

SACD+CD (2-disc set)

SSVS-015-016

¥5,500 (tax included)



Barbara Recital '67 at the Bobino Theater (1967 work)

Barbara



- ① Madam
- ② Because I love you
- ③ Longing for death (A Murir Nor Murir)
- ④ At midnight
- ⑤ at my burial ceremony
- ⑥ small cantata
- ⑦ Always talking about love
- ⑧ My Bushi Love Story: A
- ⑨ Sketch of Loneliness
- ⑩ Greedy guys

SACD+CD (2 disc set)

SSVS-013~014

¥5,500 (tax included)



Shon Parsley (acc), Michael Gobery (c)
你产: 965F12, Paris, Bobino (live)

5 titles carefully selected by stereo sound writers

Contemporary Records vol.1



- ① Art Pepper Meets the Rhythm Section
Recording: 1957
- Recommended by Takahito Miura & Stereo Round Editor
- ② Fore/Hanfu, N Has Recording: 1958
Recommended by Hiroshi Onodera
- ③ Pu Bol Tsinazu/
Bernie Kussel with Shari Man
Ang Ray Prawan Recorded:
19574 Recommended by Yamao Ohara
- ④ Hundsmide/
Kotchi Kayahara The Curtis Counce Gruno, Vol. 1
Recording: 1956 Recommended by
- ⑤ Thor Rollins &
Nintendo Ballad Leaders/Sonny Rollins Recorded: 1958--
-Recommended by Wadomi

SACD/CD hybrid ¥19,250 (5 disc set)
SSCR-001-005
(tax included)



Contemporary Records vol.2



- ⑥ Way Bout Wasted/Sonny Rollins
Recording: 1957
Recommended by Takashi Sanyo & Stereo Sound Editorial Department
- Boubany Kessel Plays Carmen Recorded: 1958
Recommended by Hiroji Onodera
- ⑦ My Fair Lady/Sinley Man Recorded: 1956
Recommended by Onara Nihon University
- Shoichi Sugawara ⑧ Ah, Pepper Noras Eleven
Bag:19594 Recommended by
- The Affair of Victor Feldman Recommended by
Recorded: 1958 Hiroshi Wada

SACD/CD Hybrid (5-disc set) 10
SSCR-006-010 ¥19,250
(tax included)



OFF COURSE BEST "ever" EMI Years

off course



Single layer SACD
SSMS-032
¥4,950 (tax included)

*This is a disc exclusively for SACD compatible players.
It cannot be played on a regular CD player.

- (1) After Wednesday
- (2) But I don't need any more flowers
- ① Sleepless nights
- ② Rainy day: income
- ③ Signs of autumn
- ④ The end of
- ⑤ I wish, don't stop living on



- *Farewell for the children who will be born at the end of the 10th century.
- ① Yes-No At 13:00, love crosses 14 billion nights
- Tarigi Kasete
- ② LOVE YOU Into the standing
- ③ bag, it's so sad
- ④ It's hard to explain
- ⑤ YES YES YES

Dialogue - Miki Imai Sings Yuming Classics -

Miki Imai



- ① Graduation photo* ② Central Funouuni*
- ③ I want to go back to that day*
- ④ I want to be a mermaid ⑤ If I were surrounded by kindness* ⑥ Cinderella Express

Single layer SACD SSMS-027
¥4,950 (tax included)

*This disc is for SACD compatible players only. It cannot be played on a regular CD player.

- *"Yum Aoi, Endgame" ① Welcome to the time to play I can't see in the drizzle ② Aoki's ~ Nogret 10 Blue Your Mail
- ③ Pain of Tokyo Train When you forget me



Wandering (Wandering)

Yoshi Ogura



- "Shiosai's Poetry" ① Spring rain is
- It's supposed to be easy
- ② Takasaki got off and time passed
- ③ Raise the door - A boy who runs away from home
- A song dedicated to that mother - Fatanas in a small town

SACD/CD/Hybrid SSMS-031
¥4,950 (tax included)



- *August rain ① This steam train is ② Koi beach
- ③ That person is gone, please give me some love ④ He died.
- 12 A car without a driver ⑤ The business of the sky
- ⑥ Farewell to youth

Shot (1982 work)

Ami Ozaki



- ① I'm a Lady Tiger ② Sorry Darling ③ To the castaways
- ④ WHO? ⑤ Stop My Love
- ⑥ It's Easy If You Try ⑦ My Song For You
- ⑧ Morning Walker Raise your hand!
- ⑨ After The Show

Executive Producer: Yuzo Watanabe
Directed & Recording Co-ordinated by Osamu Kuramoto
Mixing Engineered by Eiji Ichinuma

SACD/CD hybrid SSMS-023
¥3,850 (tax included)



Air Kiss (1981 work)

Ami Ozaki



- ① Deep
- ② Glass of Rouge
- ③ Foggy Night Lover
- ④ on the silver screen
- ⑤ 純情
- ⑥ Flash Back
- ⑦ The color of the heart is the color
- ⑧ of the sea Just Once Again

Produced by Yuzo Watanabe & Ami Ozaki
All Songs Arranged by David Foster
Engineer & Mixed by George Massenburg

SACD/CD Hybrid SSMS-022
¥3,850 (tax included)



Pink Lady | Aku Yu Works Collection |

pink lady



SACD+CD (2-disc set)
SSMS-043-044 ¥4,950 (tax included)

- ① Inspector Pepper
- ② S.O.S
- ③ Carmen 77
- ④ Qing's Sinbad
- ⑤ Wanted
- ⑥ UFO
- ⑦ Soursper
- ⑧ Monster



- ⑨ Invisible Man
- ⑩ chameleon army
- ⑪ Zipangu
- ⑫ Surfing Pirates (Yamabukomi)
- ⑬ monday mononoza kup
- ⑭ OH!
- ⑮ carmen shower
- ⑯ Shinkoainjoha

Minami Saori Single Collection

Minami Saori



SACD/CD/Hybrid SSMS-034-035
¥5,940 (tax included)

- [DISC 1]
- ① 17
- ② cool breeze melody
- ③ Friends
- ④ Purity
- ⑤ page of sadness
- ⑥ Port in early spring ⑦ Where are the fish?
- ⑧ A hurting
- ⑨ A changing color: a piece of innocence, a shadow of two roses
- ⑩ Summer impressions
- 14: Night mist
- 15 women
- virtual luck

青い空

- [DISC 2]
- ① I miss people
- ② Hitoname
- ③ Looking back at the morning
- ④ Call me when you feel like it
- ⑤ Don't be ashamed of your blue coat
- ⑥ sad fairy
- ⑦ Since I met love
- ⑧ A swaying afternoon
- ⑨ Love song on the street corner
- ⑩ Kogarashi spirit
- Koharu Pharmocotion
- I've been mellow-
- Generation Without
- ⑪ love Ms.
- 14: Goodbye Girl
- ⑫ my departure



Mastering Engineer: Koji Suzuki Lynano
Manabu Yuasa, Earth

Lover (1980 work)

Mayumi Tsuwa



SACD/CD hybrid SSMS-036
¥3,960 (tax included)

- ① Lover
- Now you suddenly become a romantic playboy
- ② Joka
- ③ Don't know my feelings,
- ④ I'm jealous
- ⑤ Memories are always

- ⑥ 10 Mirrors of Love (Sandcastle)

Mastering Engineer: Koji Suzuki
Rainer No: Jin Miura, Ichi



POINTS-2 (1986 work)

Ami Ozaki



SACD/CD Hybrid SSMS-021
¥3,850 (tax included)

- ① Cloudy then sunny... (Provided to Kei Shimura)
- (2) Boi season (Provided by Yuki Ichimaru)
- ③ I want to return my tears to the sea (Delivered to Ami)
- ④ I'm missing ⑤ (Delivery to Minami)
- (5) Summer Beach (Shoko) (Delivery to Yukiko Okada)
- ⑥ Know How (To Mayo Matsumoto)
- ⑦ Melody of the breeze, fusion (To Naoko Kawai, Yodo) (To Seiko Matsuda, Buddha)
- ⑧ of summer
- ⑨ Air Mail (newly written)
- ⑩ To see the sunset (Iyo Matsumoto)

Produced by Ami Ozaki
Recording Engineers: Peter T Lewis, Naouc Maeda, Shinichi Yano



HOT BABY (1981 work)

Ami Ozaki



SACD/CD hybrid SSMS-020
¥3,850 (tax included)

- ① Love Is Easy ② remains on your body
- ③ Cat's eye
- *A flower has bloomed at the end of unrequited hatred.
- ④ Angela
- ⑤ Prism Train
- ⑥ Wanderer In Love ⑦ Blue Night Song - Maremade

Produced by Yuzo Watanabe & Ami Ozaki
All Songs Arranged by David Foster
Engineered & Mixed by Al Schmitt



SACD/CD hybrid
Single layer SACD+CD
Single layer SACD



Don't Smoke in Bed (1993)

Holly Cole



- ① I Can See
- Clearly Know 2
- Don't Stop Tears
- ③ Get Out, Ono Town
- 4 So and So
- ④ Tennessee Waltz
- 6 Honoday
- ⑤ Blame It On My Youth
- ⑥ Everything
- Maybe Got,
- 9 Zaraiyo
- 10 Cry
- Gaku Mara
- ⑦ Sera Don't Smoke in Bed

SACD/CD hybrid
SSVS-008
¥3,850 (tax included)



Things for Lovers (1972)

Ann Burton



- ① A boy named Charlie Poorwan
- ② Visius Goes On As Casual
- ③ Sweet Williams
- ④ For No One
- (5) Got to Get You Into My Life
- ⑥ Reel Man You've Had a Business Day
- (7) Fiber and Rain
- ⑧ My Ship
- ⑨ Our Oath
- ⑩ until you go

SACD/CD hybrid
SSVS-007 ¥
¥3,850 (tax included)



Whispering Night (1979 work)

carla bonoff



- ① Dyled with tears
- A whispering night
- ② letter
- 4 A dazzling
- ③ person, I feel alone
- ④ Baby Don't E
- ⑤ Burn quietly
- (8) Loving Yu

SACD/CD hybrid
SSVS-004
¥3,850 (tax included)



First Kiss (1988)

Fairground Attraction



- ① Smile of love
- ② Pernoect
- ③ Moon on the Rain
- (4) Find My Love
- (5) Fair Ground-attraction
- 6 My name that the wind knows Miso G
- (7) Claire
- *Comedy Waltz
- 9) Moon is Mine
- ⑩ Whispers, the child on the
- ⑪ street in front of the station
- (2) Hallelujah
- 13 Fornong Pakleys

SACD/CD hybrid
SSVS-005
¥3,850 (tax included)



Street Corner Poetry (1985 work)

Suzanne Vega



- ① Undertow
- Vensome Journey
- ② The Statue of Marlene
- ③ Small Blue Thing
- ④ Straight Lines
- ⑤ Night Meurice
- ⑥ The

SACD/CD hybrid
SSVS-009
¥3,850 (tax included)



JT (1977 work)

James Taylor



- (Your smile
- ② There We Are
- ③ Honey Mint Rev L.A. Broadway 4 Sad
- (5) Bartender's Blues
- ④ secret of life (Handy Man)
- 8 I just lied,
- ⑤ looking for love
- ⑥ Highway 4 Sad
- 10 Tef Nova
- Traffic Jam
- ⑦ Hide your heart

SACD/CD hybrid
SSVS-003
¥3,850 (tax included)



Ultimate Collection (2016 work)

Roy Orbison

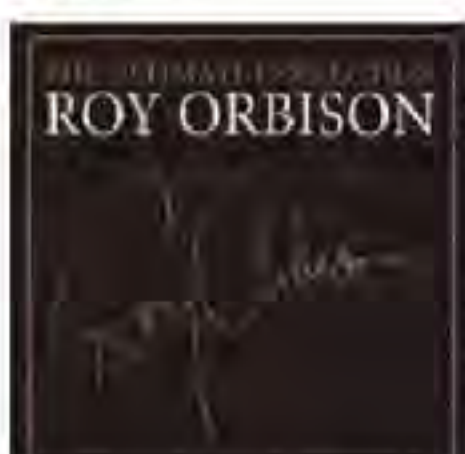

SACD/CD hybrid
SSVS-006
¥4,584 (tax included)



- ① Oh Nority Worman
- ② I Drogue All Nigh
- ③ You Got It
- ④ Kuffing
- ⑤ Only Re Lonely
- 6 in Dreams
- Brave Hearts
- ⑥ Black
- Det *Blue Bayou
- ⑦ dream baby
- ⑧ Walk on
- ⑨ Falling
- ⑩ Running Scared
- 14 California Bull
- ⑪ rear
- (6) Mean Woman Blues
- ⑫ Crawling Back (Feed Away)
- ⑬ soon to now
- 20 She's A Mystery To Me
- ⑭ blue angel
- 22/Tsu Oria
- ⑮ Udo Doodo
- 2 Her, Pleiku Radio I'm
- ⑯ no longer alone*
- ⑰ Handle Words Care★

★marks are Traveling Filberis

All Is Love (1957)

Nat King Cole



- ① The town I fell in love with (MONO)
- ② Stardust (MONO)
- ③ Stay as sweet... as you are (NO/O)
- ④ Thank you very much (MONO)
- (5) I Love You Too Much (MONO)
- ⑥ Fuve Letters (MONO)
- ⑦ I stopped cheating (MONO)
- (8) All about Marie (MONO)
- ⑧ At Last (MONO)
- ⑨ A Game Named Love (MOVO)
- Linnny Gets Blue (MCNC)
- ⑩ Love is everything (MONO)
- ⑪ When I fell in love (STEREO)
- (Sta Dust (STCRCO)
- * Stay As Sweet, As You Are (STEREO)
- ⑫ October (STEREO)
- ⑬ I Love You Tong Much (MONO)
- ⑭ Love Letters (MONO)
- ⑮ I stopped cheating (STEREO)
- 20 It's all about Mari (STEREO)
- ⑯ At Last (STEREO) A
- Game Named Inui Ren (STEREO)
- ⑰ When Sir Gets Noru (STEREO)
- ⑱ Love is everything! STEREO>

SACD/CD hybrid SSVS-010

¥4,584 (tax included)



*5 songs and 17 songs, 6 songs F and 18 songs (4 songs used stereo)

[PHILIPS (DECCA)]
Rossini: Sonatas for string orchestra (6 pieces)
 Salvatore Accardo (vn) Sylvie Gazot (vn) and others



Recorded: October 21, 1978 -
 2711, Switzerland, Fu Shephon

SACD+CD (4-disc set)
 SSHRS-047-050
 ¥10,120 (tax included)



[DECCA]
Mozart: Symphonies No. 25 & 29
 Conductor: Benjamin Britten English Chamber Orchestra



Recording: February 1971 281 [No. 29],
 September 29th
 "No. 25 1 Suffolk, Snape, Cell" Inks
 Recording producer: Ray Minshall [No. 29]
 David Harvey [No. 25]
 Balance Engineer: Kenneth Filkinson

SACD+CD (2-disc set)
 SSHRS-045-046
 ¥5,500 (tax included)



[MERCURY]
Brahms: Violin Concerto

Josef Szigeti (Vn) Conductor: Herbert Menges London Symphony Orchestra



Recorded: June 26-28, 1959
 Watford Town Har, London
 suburbs Basic recording setup:
 Wilma Saert, C, Robert Fine
 Recording director: Harold Lawrence
 Engineer: Robert Everenz

SACD+CD (2-disc set)
 SSHRS-043-044 ¥5,500
 (tax included)



[MERCURY] Prokofiev:
 <<Love for the Three Oranges>> Suite Scythian Suite

Conductor: Antal Dorati London Symphony Orchestra



Recorded: July 41, 1957, outside London,
 Futofo Town Hall
 Recording Director: Wilma
 Fusato Musical Supervisor:
 Harold Nielsen
 Chief Engineer & Technical Supervisor:
 C. Robert Fine

SACD+CD (2-disc set)
 SSHRS-041-042 ¥5,500
 (tax included)



[MERCURY]
Stravinsky: Ballet "The Firebird"

Conductor: Antal Dorati London Symphony Orchestra



Recorded: May 7, 1959, outside London.
WATFREY TOWN
 HALL Recording Director:
 Wilma Fleet Musical Supervisor: Harold Lawrence
 Chief Engineer & Technical Supervisor:
 C. Nibert Fein
 Associate Director: Robert Everenz

SACD+CD (2-disc set)
 SSHRS-039-040
 ¥5,500 (tax included)



[LONDON (DECCA)]
Mahler: Symphony No. 3

Los Angeles Philharmonic Orchestra conducted by Zubin Mehta



Meerin Forrester, Los Angeles Masters,
 Chorale, Califure Boys Choir
 Recorded: March 27-31, 1978 Californian
 Studios Frinzels Royce Hall, California
 Producer: Ray Minshall
 Engineer: Gimz Rock, Nimin Yeadon,
 Markel Maris

2SACD+2CD (4-disc set)
 SSHRS-035-038
 ¥10,120 (tax included)



[DECCA]
Albéniz: Spanish Suite (Arranged by Burgos)

New Philharmonia Orchestra conducted by Rafael Frúbeck de Burgos



Chantai: 1st and 2nd
 November 1967 Kingsway Hall, London
 Producer: John Maudler
 Engineer: Keith Filkinson,
 Alan Reeve

SACD+CD (2-disc set)
 SSHRS-033-034 ¥5,500
 (tax included)



The ultimate piece of historical performance recorded on
 a quartz glass CD "J.S. Bach: Goldberg Variations" Glenn Gould



[Only a few left]

①JS Bach: Golbenberg Variations
 Note: This is a 1-year digital recording of a precious
 master tape that has never been made into a digital
 disc, and has been put straight into an English Pallas
 CD using the latest technology. Sales quantity: 200
 pieces (completely limited production, serial number
 1 piece)

glass cd
 SGCD02
 ¥143,000 (tax included)



[DECCA]
Wagner: Stage play "The Ring of the Nibelungen"
 Day 3 《Twilight of the Gods》



Conducted by Sir Georg Solti
 Vienna Philharmonic Orchestra, etc.

* Disc, hackage specifications
 · Single layer SACD
 · Jacket size: LP size large ·
 Deluxe booklet included

Single layer SACD (4-disc set)
 SSHRS-025-028
 ¥23,100 (tax included)



[DECCA]
Wagner: Stage play "The Ring of the Nibelung"
 Day 2 《Siegfried》



Vienna Philharmonic
 Orchestra conducted by Li Georg Solti, etc.

*Disc and package specifications
 · Single layer SACD ·
 Jacket size: 1" large · Deluxe
 booklet included

Single layer SACD (3 disc set)
 SSHRS-022-024
 ¥20,350 (tax included)



SACD/CD Hybrid
Single Layer SACD + CD
Single Layer SACD



Direct SACD/CD conversion from original master

tape Stereo Sound Co., Ltd. has flat-transferred the original analog master tapes into two formats, single-layer SACD and CD, and converted them into digital discs. What we have is the "Audio Masterpiece Collection." A major feature is that you can enjoy to the fullest the characteristics and potential of each disc format: SACD, which is converted directly to DSD from an analog master tape, and CD, which is converted to PCM by playing back the master tape.

[DECCA]
Mendelssohn:
Symphony No. 3 "Scotland", Overture "Fingal's Cave"

London Symphony Orchestra conducted by Beta Mark



Recorded: April 21 and 22, 1960
Kingsway Hall, London
Producer: Ray Minshall
Tunzier: Kenneth Wilkinson

Released on April 5, 2022
SACD+CD (2 disc set)
SSHRS-056~057
¥5,500 (tax included)



[DECCA]
Dvorak:
Symphony No. 8, Scherzo Capriccioso

London Symphony Orchestra conducted by Istvan Kertesz



Recorded: February 22, 23, 25, 26, 1963
London, Kingsway Hall
Flory: Ray Minshall
-Njia: Arthur Lu, Michael Myles

Released on April 6, 2022
SACD+CD (2-disc set) SSHRS-058~059
¥5,500 (tax included)



[DECCA]
Britain: War Requiem

London Symphony Orchestra conducted by Benjamin Britten, etc.



"Galina Vishnevskaya (Sofano)
Peter Pierce (Tenor)
Tenotrich Fischerdi Sukawa (baritone)
Recorded: January 3-5, 7, 8,
10, 1963 Kingsway Hall, London
Protusa: John Culcio
Engia Kenneth Filkinson, Michael Myles

Released on April 5, 2022
2SACD+2CD (4-disc set)
SSHRS-060~063
¥10,120 (tax included)



[DECCA]
Wilhelm Backhaus Last Concert
Wilhelm Backhaus (p)



Beethoven: Piano Sonata No. 21 Ewartstein, No. 18 (up to the 3rd movement)
Schubert: At the Musical, Impromptu Op. 142-2,
Mozart: Piano Sonata No. 11 [with Turkish March], etc.
Recorded: June 26 and 28, 1969, Ossiach, Austria
Tyinob Church

Released on April 6, 2022
2SACD+2CD (4-disc set)
SSHRS-064~067
¥10,120 (tax included)



[PHILIPS (DECCA)]
Debussy & Ravel: String Quartet
Italian string quartet



August 11~14, 1965
Novoy Theater, Vevey, Switzerland
Producer: Vittorio Negri
Engineer: Tony Puczynski

Released on April 5, 2022
SACD+CD (2-disc set) SSHRS-068~069
¥5,500 (tax included)



[DECCA] Wagner: Golden Ring~
Highlights of the opera "The Ring of the Nibelung"
Conductor: Sir Georg Solti Vienna Philharmonic Orchestra and others



Recording: 1958-1965
Wynn, Sophie Nimple
Producer: John Culshaw
Recording Engineer: Gordon Parry

Single layer SACD SSHRS-055
¥5,500 (tax included)



[DEUTSCHE GRAMMOPHON]
Tchaikovsky: Piano Concerto No. 1

Sviatoslav Richter (p) Conductor: Herbert von Karajan Vienna Symphony Orchestra



Recorded: September 21-26, 1962,
Musikvereinsal, Vienna
"Recording producer: Otto Ernst Wohlerl"
Balance engineer: Gunter Hermanns

SACD+CD (2 disc set) SSHRS-053~054
¥5,500 (tax included)



[PHILIPS (DECCA)]
Vivaldi: Concerto collection "The Four Seasons"
Musici Ensemble Felix Ayo (vn)



Recorded: April 29 - May 6, 1959 in
Vienna Recording producer: Vittorio
Negri Recorder: Tony Buczynski
Recorder: Hans Lauter slager

SACD+CD (2-disc set)
SSHRS-051~052 ¥5,500 (tax included)



This disc was created using a new digital transfer using the (nanosony) analogmaster stored at Deutsche Grammophon. Since no Kusuruki processing has been performed on the volume, the noise, theft, dropouts, etc. contained in the master tape are present to an extent that cannot be compared with commercially available products. Especially in Tsuguo 2, you can always hear loud noises throughout the movie. Please be aware of this before purchasing.



A special version of the machine that combines 50 years of technology.

A tube amplifier that goes beyond the concept of a 300B amplifier.

Uesugi Institute 50th Anniversary Model/Special Specification

UESUGI U · BROS330AH Limited Edition

WE 300B (current tube reprinted in 2021) Output tube attached specifications

U-BROS330AHW-WE ----- ¥2,310,000

PSVANE WE300B output tube included specifications

U-BROS330AHW-PS ----- ¥2,035,000

Only front tube included, no output tube 300B

U-BROS330AHW-L ----- ¥1,815,000

*All prices include consumption tax and shipping, and are a pair. The W in the model name indicates a special limited production white chassis. *You can choose with or without the optional vacuum tube protection cover G330W (¥44,000, tax included, pair = black leather-like paint).

Application deadline: Thursday, January 5, 2023

Standard delivery date: Ships from late March 2023 in the order received.



U-BROS330AH Limited Edition has a pearl white chassis

The paint and transcase are finished with black leather-like paint. The front stage consists of four vacuum tubes: a GE 12AX7A with the first stage and a positional inversion tube, an Electro Harmonix 6CG7 with the second stage, and a Philips 12AT7 which forms a cathode follower circuit in parallel. I am. The use of highly reliable true tubes is unique to Uesugi amplifiers, and the output tube included is the 300B, which was fully managed by Uesugi Research Institute.

the founding of Sugi Research Institute
thermal triode 300B commemorating the 50th anniversary of

U · BROS330AH is the top of the city
Chevre monaural power amplifier

filament. There is a circotron in the setup.

Uesugi Kawa Riki circuit, and 300B

amplifier is AC ignition, Maku generation

technology of the 300B vacuum tube power

were fully mobilized. The core

Push-pull table force stage increases table force.

Large and long-term reliability can be ensured.

unique to 300B, and Nichiryoku is 30W.

The sound is the AB class operation

and elegance of modern large-scale models.

It has a body feel that matches the slimmess

with the original speaker

reproduces tight low frequencies Combination

Demonstrates great potential and

BROS330AH Limited

Edition Stereo Sound Stamp

transceiver is painted. Chassis is par

piano white, and the

The leather is painted with

transformer case keyboard motif.

bra chassis and the black

The contrast is between the Uesugi

high-quality Texundo. Limited special

specification, it has a design originating from

Served with Chua. As a separate

Product features

Maximum output: 30W Input terminal: LINE 2 systems (RCA unbalanced, fixed/variable) Speaker output terminal: 40, 80, 160 Vacuum tubes used: ECC83/12AX7A (GE) x 1, 6CG7 (Electro Harmonix) x 1, ECC81/12AT7 (Philips ECG) x 2, 300B (reprinted Western Electric) x 2 *The presence or absence of an output tube and the brand vary depending on the specifications Dimensions/Weight: W364x H201xD218mm/17.5kg

For inquiries regarding product specifications: Uesugi Research Institute Phone number 044(712)4632

A separate shipping fee will be charged in addition to the product price.

For purchasing instructions, please see the "Purchase Instructions" on pages 14-15 of the catalog.



check disk
NORDOST
SYSTEM SOLUTION
SET-UP & TUNING DISCS ¥5,610 (tax included)



Equipped with ion static eliminator YUKIMU ASB-2 ion static
eliminator brush
for audio ----- ¥21,450 (tax included)



Cartridge stand
N2 Factory N2-
S2 [Shell Stage S2] ----- ¥13,640 (tax included)



Label protector for LP record cleaning
NAGAOKA
CLP02 ----- ¥3,278 (tax included)



3WAY record bag
KIKUTANI DJB-65 ¥5,720
(tax included)



•Number of records stored: Approximately
25 (for our heavy-duty album jacket)
*The record in the photo is not included in
the product.





Mail order information

How to order online

Please use our online shop [Stereo Sound Store].



https://www.stereosound-store.jp

Order procedure

STEP1 [Add to cart]

Once you have decided on the product you would like to order, click the "Add to Cart" button on the name/product page. After checking the product, proceed to the purchase process.

STEP2 [Purchase procedure]

Following the instructions on both sides, we will manually enter your location and customer information. By registering as a member, you can enjoy shopping smoothly from next time without having to enter your name or address.

STEP3 [Confirm your order]

After selecting the shipping method and payment method, please confirm and receive the final details and then press the "Order Confirmation" button. Once your order has been confirmed, we will contact you by email.

Payment method

On the purchase procedure screen, you can choose from the following payment methods. For details, please see "Shipping and Payment" on Stereo Sound Store.

① Credit card payment

Various credit cards are accepted.

Compatible



*Instalments and revolving payments are available.

*Bonus lump sum payment is not available.

② Amazon Pay

You can use the shipping address information, credit card, and notification information registered in your Amazon.co.jp account for payment.

③ Rakuten Pay

You can make credit card payments using the Rakuten Member ID that you have registered on Rakuten Market, etc.

*To use Rakuten Pay, you must register your credit card with Rakuten Kai Busho.

④ Mobile Edy

This method allows you to use your mobile phone during the purchase procedure and pay with electronic money. Can be used with FeliCa compatible mobile phones.

⑤ Cash on delivery

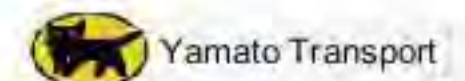

Please pay the product price to the delivery company when placing the product. -A handling fee will be charged depending on the total amount of product purchase and shipping.

- As a general rule, the upper limit for cash on delivery is 300,000 yen (including shipping and tax).
- Payment can be made by cash or credit card. -Cash on delivery is not available in some areas.

(6) Bank transfer

A payment method in which the payment is transferred to the account specified by our company after placing your order is.

Transfer destination: Nisubishi UFJ Bank (financial institution code: 0005) Shoto Branch (branch number: 570)

Account name: Ka) Stereo sound

11th seat number: Current 0000026

※ The transfer fee will be paid by the customer. As soon as we confirm your payment, we will arrange for the product to be shipped. If payment is not received within 3 days, your order will be cancelled.

⑦ Convenience store payment

Operate the information terminals installed at each convenience store. This is a payment method where you pay in advance at the store. Available with no payment fees. The redemption method differs depending on each convenience store.

Convenience stores available:
Lawson/Family Mart/Seiko Mart



*The upper limit of the amount that can be paid is less than 300,000 yen.

inquiry

Stereo Sound Co., Ltd. Sales Department

Mail order dedicated dial: 03-5716-3239

Reception hours: Weekdays 10:00~17:30

Stereo Sound

Stereo sound original music software catalog

This catalog introduces all of our original music software such as CDs, SACDs, and LPs. In addition, a web discount coupon worth a total of 1,500 yen that can be used at our online shop "Stereo Sound Store" is included.

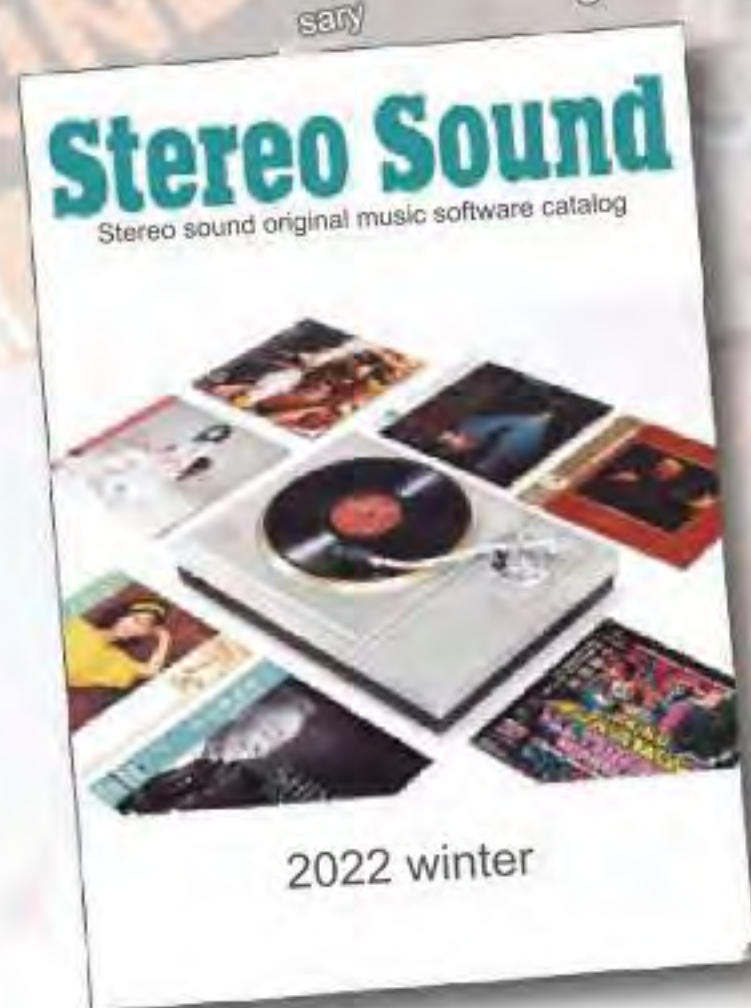

● Distribution price: 350 yen (tax and shipping included)

● Delivery method:

Delivery will be made via Yamato Transport or Nekoposu (post-mail).

● How to apply

Please write "Original Music Software Catalog" on the payment slip attached to Stereo Sound Store or our publications and apply.

WEB discount coupon details

Contents: Total 1,500 yen (500 yen x 3 doses)

[Validity period]

3 months after you receive the coupon

[Terms of use]

- To use the web discount coupon, you need to register as a member of our online shop "Stereo Sound Store". (*)
- If the total product price (excluding tax and shipping) for one order is 3,000 yen or more, a discount of 500 yen will be applied to the total amount.
- Multiple orders cannot be used together in one order.
- Cannot be used in conjunction with other coupons.

*WEB discount coupons cannot be used on payment slips or for ordering products over the phone.

inquiry

Stereo Sound Co., Ltd. Sales Department

Mail order only dial: 03-5716-3239

Reception hours: Weekdays 10:00~17:30

PASS



DCD-A110
SACD Player

PMA-A110
Integrated Amplifier

AVC-A110
AV Surround Amplifier

DL-A110
MC phono cartridge with
premium silver-graphite headshell



DENON®

110
Anniversary

www.denon.jp/ja-jp/110years



9784880734873



1929473026005

Magazine code 65482-91

April 2023

©2022 STEREO SOUND Publishing Inc.

Printed in Japan Printing/Okuchiki Printing

ISBN978-4-88073-487-3

C9473 ¥2600E

Sound 2023 (Winter issue) December 13, 2022 (Published/released pm) Volume 4 Issue Circular No. 225 • Advertisement planning
• Publisher/ Editor Hajime Harada Editor Hajime Someya • Shikkai Stereo Sound 5-12-11 Kamiyoga, Setagaya-ku, Tokyo 158-0055 • Editorial Department (03) 5716-3115 FAX: 03-5716-3203 St. ps:/oni ne.stereosound.ac.jp/ Quarterly Stereo

Department:03:57.63.39 • Sales Department(03)57.6333/AX:03-57-63226
List price 2,860 yen, main unit 2,600 yen